



**MTH500**

**TETRA Portable Radio  
R1:380-400 MHz (PT811F)**

**Detailed Service Manual**

**Part Number: 6802963C70**



Printed on recycled paper. Environmentally friendly cover and spiral bound. European Publications Department .  
68P02963C70-O, Issued: 05.02.

## Scope of this Manual

This manual contains information necessary to identify and troubleshoot the MTH500 Portable radio at the component level. It also contains information on radio assembling, disassembling, and maintenance. Accordingly, information in this manual is divided into four sections:

- Overview
- Theory of Operation
- Troubleshooting
- Radio Programming
- Maintenance

## Manual Revisions

Changes which occur after this manual is printed are described in Manual Revisions. These Manual Revisions provide complete information on changes including pertinent parts listing data.

## Related Publications

- 68P02963C30-O MTH500 User Guide
- 68P02963C65-O MTH500 Basic Service Manual
- 68P02956C20-F CPS User's Guide
- IFR-Operational Manual Supplement 46882-324
- IFR-Operational Manual 46882-274T

## Computer Software Copyrights

The Motorola products described in this manual may include copyrighted Motorola computer programs stored in semiconductor memories or other media. Laws in the United States and other countries preserve for Motorola certain exclusive rights for copyrighted computer programs, including the exclusive right to copy or reproduce in any form the copyrighted computer program. Accordingly, any copyrighted Motorola computer programs contained in the Motorola products described in this manual may not be copied or reproduced in any manner without the express written permission of Motorola. Furthermore, the purchase of Motorola products shall not be deemed to grant either directly or by implication, estoppel, or otherwise, any license under the copyrights, patents or patent applications of Motorola, except for the normal non-exclusive royalty free license to use that arises by operation of law in the sale of a product.

## Trademarks

MOTOROLA and the Stylized M Logo are registered in the U.S. Patent and Trademark Office. All other product or service names are the property of their respective owners.

© Motorola, Inc. 2001

## Safety And General Information

### Important Information on Safe and Efficient Operation

#### Read this Information before Using your handset

The information provided in this document supersedes the general safety information contained in service manuals published prior to June 2001. For information regarding handset use in a hazardous atmosphere please refer to the Factory Mutual (FM) Approval Manual Supplement or Instruction Card which is included with handset models that offer this capability.

### Radio Frequency (RF) Operational Characteristics

Your handset contains a radio frequency transmitter to convey the information you wish to send as well as occasional automatic signals used to sustain connection with the wireless network, and a receiver which enables you to receive communication and connection information from the network.

## Handset Operation And EME Exposure

Your Motorola handset is designed to comply with the following national and international standards and guidelines regarding exposure of human beings to radio frequency electromagnetic energy:

- United States Federal Communications Commission, Code of Federal Regulations; 47 CFR part 2 sub-part J
- American National Standards Institute (ANSI) / Institute of Electrical and Electronic Engineers (IEEE) C95. 1-1992
- Institute of Electrical and Electronic Engineers (IEEE) C95.1-1999 Edition
- National Council on Radiation Protection and Measurements (NCRP) of the United States, Report 86, 1986
- International Commission on Non-Ionizing Radiation Protection (ICNIRP) 1998
- Ministry of Health (Canada) Safety Code 6. Limits of Human Exposure to Radiofrequency Electromagnetic Fields in the Frequency Range from 3 kHz to 300 GHz, 1999

- Australian Communications Authority Radiocommunications (Electromagnetic Radiation – Human Exposure) Standard 1999 (applicable to wireless phones only)
- Anatel, Brasil Regulatory Authority  
“This equipment is in compliance with the limits of Specific Absorption Rate which refer to the exposal to electric, magnetic and electromagnetic fields adopted by ANATEL.”

**To assure optimal handset performance and make sure human exposure to radio frequency electromagnetic energy is within the guidelines set forth in the above standards, always adhere to the following procedures:**

#### ***Phone Operation***

When placing or receiving a phone call, hold your handset as you would a wireline telephone. **Speak directly into the microphone.**

#### ***Two-way radio Operation***

When using your handset, **hold the handset in a vertical position with the microphone 2.5 to 5 cm away from your mouth.**

#### ***Body-worn Operation***

To maintain compliance with these RF exposure guidelines, if you wear a handset on your body when transmitting, always place the handset in a **Motorola approved belt clip or leather case for this product**. Use of non-Motorola-approved accessories may exceed these RF exposure guidelines. **If you do not use a Motorola approved body-worn accessory and are not using the handset in the intended use positions along side of the head in the phone mode or in front of the face in the two-way radio mode, then ensure the antenna and handset is kept the following minimum distances from the body when transmitting:**

- **Phone or Two-way radio mode: 2.5 cm**
- **Data operation using any data feature with or without an accessory cable: 2.5 cm**

#### ***Antenna Care***

**Use only the supplied or an approved replacement antenna.** Unauthorized antennas, modifications, or attachments could damage the handset and may violate FCC regulations.

**DO NOT hold the antenna when the radio is “IN USE”.** Holding the antenna affects call quality and may cause the radio to operate at a higher power level than needed.

#### ***Approved Accessories***

For a list of Approved Motorola accessories, please see “REPLACEMENT PARTS AND KITS” on page 45.

## **Electromagnetic Interference/Compatibility**

**NOTE:** Nearly every electronic device is susceptible to electromagnetic interference (EMI) if inadequately shielded, designed or otherwise configured for electromagnetic compatibility.

#### **Facilities**

To avoid electromagnetic interference and/or compatibility conflicts, turn off your handset in any facility where posted notices instruct you to do so. Hospitals or health care facilities may be using equipment that is sensitive to external RF energy.

#### **Aircraft**

When instructed to do so, turn off your handset when on board an aircraft. Any use of a handset must be in accordance with applicable regulations per airline crew instructions.

#### **Medical Devices**

##### ***Pacemakers***

The Health Industry Manufacturers Association recommends that a minimum separation of 15 centimetres be maintained between a handheld wireless handset and a pacemaker. These recommendations are consistent with those of the U.S Food and Drug Administration.

Persons with pacemakers should:

- **ALWAYS** keep the handset more than 15 centimetres from their pacemaker when the handset is turned ON.
- not carry the handset in the breast pocket.
- use the ear opposite the pacemaker to minimise the potential for interference.
- turn the handset OFF immediately if you have any reason to suspect that interference is taking place.

##### ***Hearing Aids***

Some digital wireless handsets may interfere with some hearing aids. In the event of such interference, you may want to consult your hearing aid manufacturer to discuss alternatives.

##### ***Other Medical Devices***

If you use any other personal medical device, consult the manufacturer of your device to determine if it is adequately shielded from RF energy. Your physician may be able to assist you in obtaining this information.

## Safety and General

### Use While Driving

Check the laws and regulations on the use of radios in the area where you drive. Always obey them.

When using the handset while driving, please:

- Give full attention to driving and to the road.
- Use hands-free operation, if available.
- Pull off the road and park before making or answering a call if driving conditions so require.



WARNING

## Operational Warnings

### For Vehicles Equipped with an Air Bag

Do Not place a handset or install a Vehicular Adapter in the area over an air bag or in the air bag deployment area. Air bags inflate with great force. If a radio is placed in the air bag deployment area and the air bag inflates, the radio may be propelled with great force and cause serious injury to occupants of the vehicle.

### Potentially Explosive Atmospheres

Turn off your handset prior to entering any area with a potentially explosive atmosphere, unless it is a handset type especially qualified for use in such areas as “Intrinsically Safe” (for example, Factory Mutual, CSA, UL, or CENELEC Approved). Do not remove, install, or charge batteries in such areas. Sparks in a potentially explosive atmosphere can cause an explosion or fire resulting in bodily injury or even death.

**NOTE:** The areas with potentially explosive atmospheres referred to above include fuelling areas such as below decks on boats, fuel or chemical transfer or storage facilities, areas where the air contains chemicals or particles such as grain, dust, or metal powders, and any other area where you would normally be advised to turn off your vehicle engine. Areas with potentially explosive atmospheres are often, but not always, posted.

### Blasting Caps and Areas

To avoid possible interference with blasting operations, turn off your handset when you are near electrical blasting caps, in a blasting area, or in areas posted: “Turn off two-way radio.” Obey all signs and instructions.

## Operational Cautions



Caution

### Antennas

**Do not use any handset that has a damaged antenna.** If a damaged antenna comes into contact with your skin, a minor burn can result.

### Batteries

All batteries can cause property damage and/or bodily injury such as burns if a conductive material such as jewellery, keys, or beaded chains touch exposed terminals. The conductive material may complete an electrical circuit (short circuit) and become quite hot. Exercise care in handling any charged battery, particularly when placing it inside a pocket, purse, or other container with metal objects.

## CE European Union Directives Conformance Statement

This product is in conformance with the TETRA (TErrestrial Trunked RAdio) standard.

This product is in conformance with the requirements of the applicable EU Council Directives.

Declarations of Conformance with the requirements are located at:

Motorola a/s

Midtager 20

DK-2605 Brøndby

# Contents



---

---

<b>MTH500 Portable Radio Model Information</b> .....	<b>xi</b>
<b>MTH500 Model Specifications</b> .....	<b>xii</b>
<b>MTH500 Accessories</b> .....	<b>xiii</b>
<b>Overview</b> .....	<b>1-1</b>
General .....	1-1
Digital Modulation Technology .....	1-1
Voice Compression Technology .....	1-2
Description .....	1-2
Transceiver Description .....	1-2
Digital Section Description .....	1-2
Transmitter Path Description .....	1-2
Receiver Path Description .....	1-3
Frequency Generating Section Description .....	1-3
<b>Theory of Operation</b> .....	<b>2-1</b>
Section Introduction .....	2-1
Block Diagram Overview .....	2-1
Receiver Section .....	2-2
Transmitter Section .....	2-3
Digital Section .....	2-3
Frequency Generating Section .....	2-4
Block Diagrams Descriptions .....	2-5
Receiver Path .....	2-5
Transmitter Path .....	2-6
Digital Mode of Operation .....	2-7
Frequency Generating Section .....	2-8
Main Synthesizer .....	2-9
RX Second Local Oscillator (LO) .....	2-9
Offset VCO .....	2-9
Detailed Circuit Description .....	2-10
Receiver Path, Detailed Circuit Description .....	2-10
Antenna Switch .....	2-10
Limiter .....	2-11
Front Filter .....	2-11
LNA .....	2-11
Second Pre-selector .....	2-11
Attenuator .....	2-11

---

## Contents

---

Mixer .....	2-11
IF Filter .....	2-12
BALUN .....	2-12
WPIC (receiver section) .....	2-12
Transmitter Path, Detailed Circuit Description .....	2-13
Forward Path .....	2-13
WPIC .....	2-13
LO LINE-UP .....	2-14
LNODCT .....	2-14
BALUN - FILTER .....	2-14
RF Power Amplifier .....	2-15
Coupler and Feedback Path .....	2-15
Isolator .....	2-15
Antenna Switch .....	2-15
Harmonic Filter .....	2-16
Digital Section, Detailed Circuit Description .....	2-17
Host Memories .....	2-17
Flash Memory .....	2-17
SRAM Memory .....	2-18
Serial Peripheral Interface (SPI) .....	2-18
DC Power Distribution .....	2-20
V1 Linear Regulator .....	2-20
V2 Linear Regulator .....	2-20
V3 Linear Regulator .....	2-20
V4 Linear Regulator .....	2-20
Switcher #1 (Synchronous Buck Mode Converter) .....	2-20
Switcher #2 (Boost Mode Converter) .....	2-21
DSC Linear Regulator .....	2-21
TS_REF Linear Regulator .....	2-21
VREF1 Linear Regulator .....	2-21
VREF2 Linear Regulator .....	2-21
Current Limit .....	2-21
RS232, SB9600 .....	2-23
Battery ID .....	2-23
Radio Audio System .....	2-23
Tx Path .....	2-23
Rx Path .....	2-23
Frequency Generating Section Detailed Circuit Description .....	2-25
REF. Oscillator - TCXO .....	2-26
Main VCO and Main Synthesizer .....	2-26
WPIC .....	2-26
LMX - Dual Synthesizer .....	2-27
Second LO VCO .....	2-27
Offset VCO .....	2-27
Display and Keypad Description .....	2-28
Display .....	2-28
Keypad .....	2-28
Backlight and LEDs .....	2-29
Backlight .....	2-29
Top LEDs .....	2-29
Radio Programming .....	2-29
Accessory Connector .....	2-29

---

---

Mode Select (OPTION1 and OPTION2) .....	2-30
<b>Troubleshooting .....</b>	<b>3-1</b>
General .....	3-1
Test Procedures .....	3-1
Troubleshooting Flowcharts .....	3-2
DMO Troubleshooting Charts .....	3-2
TMO Troubleshooting Charts .....	3-2
Digital Troubleshooting .....	3-3
Digital Analysis Test .....	3-3
Digital Analysis Test (Cont.) .....	3-4
Digital Analysis Test (Cont.) .....	3-5
Digital Analysis Test (Cont.) .....	3-6
DC Distribution (V2_2.775V) Test .....	3-7
DC Distribution (V2_2.775V) Test (Cont.) .....	3-8
DC Distribution (V2_2.775V) Test (Cont.) .....	3-9
DC Distribution (V2_2.775V) Test (Cont.) .....	3-10
DC Distribution (SWB+) Test .....	3-11
DC Distribution (V4_2.775V) Test .....	3-12
DC Distribution (V3_2.775V/PWM2_1.8V) Test .....	3-13
DC Distribution (V5_RF/PWM1/VSIMI_5.6V) Test .....	3-14
Transmitter Troubleshooting .....	3-15
Standby Current Troubleshooting .....	3-15
Open Loop Power Test .....	3-16
Open Loop Power Test (Cont.) .....	3-17
Open Loop Power Test (Cont.) .....	3-18
WPIC Test .....	3-19
Closed Loop Power Test .....	3-20
Transmitter Current Consumption Test .....	3-21
Receiver Troubleshooting .....	3-22
Synthesizer Troubleshooting .....	3-23
Synthesizer Troubleshooting (Cont.) .....	3-24
Second LO VCO Test .....	3-25
Offset VCO Test .....	3-26
Audio Troubleshooting (External Mic to External Out) .....	3-27
<b>Programming the Radio .....</b>	<b>4-1</b>
Programming The Radio .....	4-1
Codeplug Programming .....	4-1
Application Programming .....	4-2
<b>Maintenance .....</b>	<b>5-1</b>
Preventive Maintenance .....	5-1
Inspection .....	5-1
Cleaning .....	5-1
Safe Handling of CMOS Devices .....	5-2
Disassembling and Reassembling the MTH500 Unit .....	5-2
Protecting Static-Sensitive Devices .....	5-3
To create a proper ground: .....	5-3
To store or transport a circuit board: .....	5-3

---

## Contents

---

Removing and Installing the Antenna .....	5-4
To remove the antenna from the unit: .....	5-4
To install the antenna in the unit: .....	5-4
Removing and Installing Battery Door and Battery .....	5-4
To remove the battery door from the unit: .....	5-4
To remove the battery: .....	5-5
To install the battery: .....	5-6
To install the battery door: .....	5-6
Removing and Installing the Back Housing .....	5-6
Removing the back housing from the unit: .....	5-6
Installing the back housing: .....	5-7
Removing and Installing the Vibrator .....	5-7
Removing the vibrator: .....	5-8
Installing the vibrator: .....	5-8
Removing and Installing the Main Board .....	5-9
Removing the main board from the unit: .....	5-9
Installing the main board: .....	5-9
Removing and Installing the Keypad and LCD Boards .....	5-10
Removing the keypad and LCD boards from the unit: .....	5-10
Installing the keypad and LCD boards: .....	5-11
Removing and Installing the LCD Module Assembly .....	5-12
To remove the LCD module assembly from the unit: .....	5-12
To install the LCD module assembly: .....	5-13
Removing and Installing the Keypad .....	5-14
Removing the keypad: .....	5-14
Installing the keypad: .....	5-14
Removing and Installing the Microphone .....	5-15
Removing the microphone: .....	5-15
Installing the microphone: .....	5-15
Removing and Installing the Earphone .....	5-15
Removing the earphone: .....	5-15
Installing the earphone: .....	5-15
MTH500 Components List .....	5-17
<b>Component Board Layouts .....</b>	<b>6-1</b>
<b>Schematic Diagrams and Parts Lists .....</b>	<b>6-7</b>
<b>Appendix 1 Replacement</b>	
<b>Parts and Kits .....</b>	<b>A1-1</b>
Ordering Parts .....	A1-1
Level 3 Maintenance .....	A1-1
EMEA Region .....	A1-1
Latin America Region .....	A1-2



**Appendix 2 Test Equipment, Service Aids & Tools** ..... **A2-1**

**Appendix 3 Self Check Error/Fail Code Tables** ..... **A3-1**

    General ..... A3-1

    Self Check Error Codes ..... A3-1

**Appendix 4 Glossary** ..... **A4-1**

**THIS PAGE INTENTIONALLY LEFT BLANK**

## MTH500 Portable Radio Model Information

This manual applies to the following MTH500, 1W, Hand-Held Portable Radio Models:

Black H39PCN6TZ5AZ, 380-400MHz

Blue H39PCN6TZ5AR, 380-400MHz

### MODEL NUMBERING SYSTEM

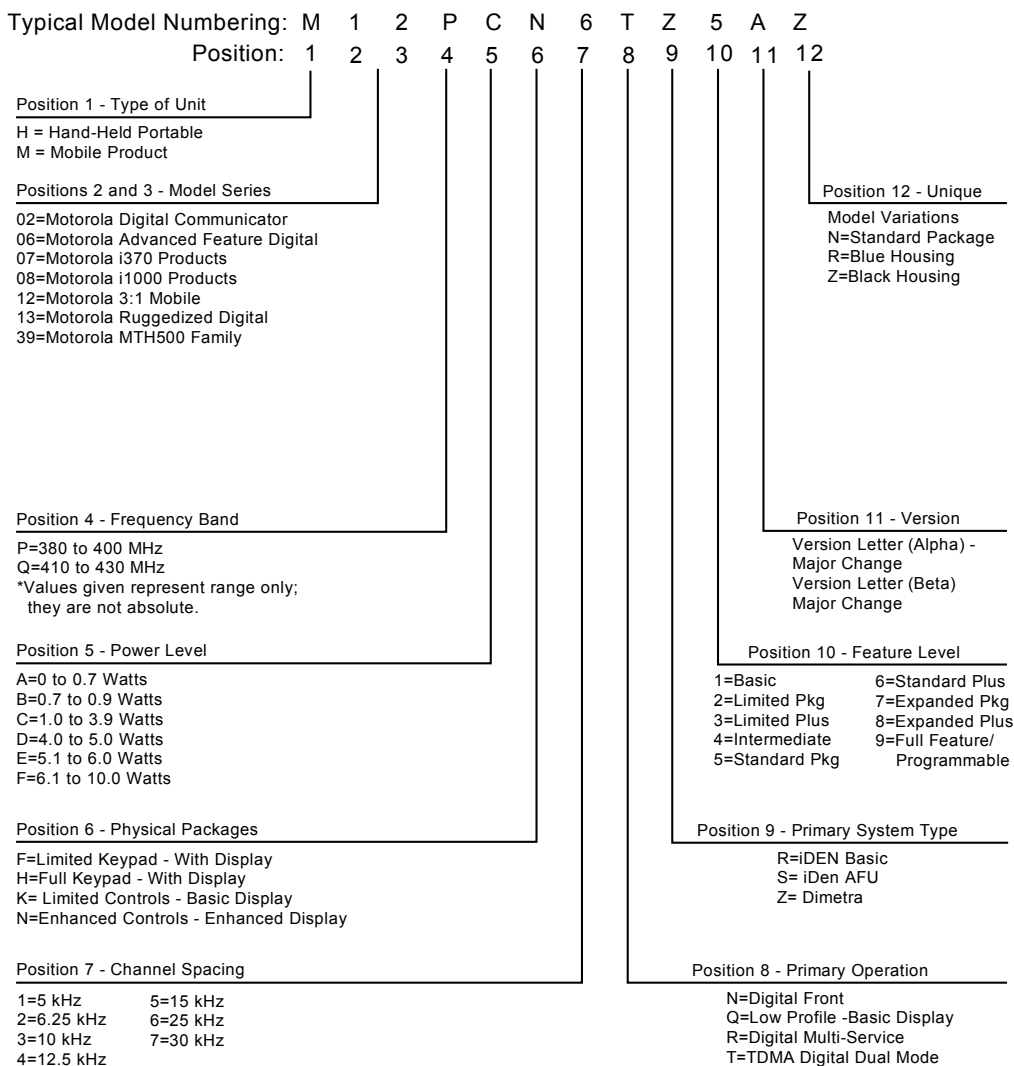

# MTH500 Model Specifications

GENERAL		RECEIVER		TRANSMITTER	
<b>ETSI</b>	ETS 300 394-1	<b>Receiver Type:</b>	Class A and B	<b>Modulation Type:</b>	$\pi/4$ DQPSK
<b>Type Number:</b>	R1:380-400 MHz; PT811F	<b>Frequency Range:</b>	R1:380-400 MHz		
<b>Temperature Range for Transceiver:</b>		<b>Channel Spacing:</b>	25 kHz	<b>RF Power</b>	1Watt
Operating:	-20°C to +60°C	<b>Sensitivity (4%) BER:</b>	-112 dBm	<b>Frequency Range:</b>	R1: 380-400 MHz
Storage:	-40°C to +85°C	<b>Intermodulation: Interfering Signal Level:</b>	(4%) BER -47 dBm	<b>Frequency Stability:</b>	Locked to Base $\pm 100$ Hz Not Locked to Base $\pm 2$ ppm
<b>Battery Types:</b>	Standard SNN5705B 800mAH (Lilon), Standard SNN5705C 800mAH (Lilon), High Capacity SNN5706A 1100mAH (Lilon)	<b>Selectivity Blocking: (50-100 kHz) Interfering Signal Level:</b>	(4%) BER -40 dBm	<b>Spurious Emissions</b>	
		<b>Spurious Rejection: Interfering Signal Level:</b>	(4%) BER -45 dBm	<u>Conducted</u>	
				30MHz-1GHz	-36dBm
				1GHz-4GHz	-30dBm
				<u>Radiated</u>	
				30MHz-1GHz	-36dBm
				1GHz-4GHz	-30dBm
<b>Battery Voltage:</b>		<b>Frequency Stability:</b>	Locked to Base $\pm 100$ Hz Not Locked to Base $\pm 2$ ppm	<b>Adjacent Channel Power (at<math>\pm 25</math>kHz)</b>	- 60 dB
Minimum:	3.4 Vdc	<b>Audio Rated:</b>	0.5 W		
Nominal:	3.8 Vdc	<b>Distortion at Rated Audio:</b>	5% Max.		
<b>Portable Dimensions HxWxD in MM:</b>	140x55x31 mm				
<b>Weight:</b>	$\leq 155$ gr, without battery				

Specifications subject to change without notice.

## MTH500 Accessories

Kit Number	MTH500 Model Description
<b>Batteries</b>	
FTN6030A	Extended battery, 1100mAh, Lilon, Black (with battery door)
FTN6037A	Extended battery, 1100mAh, Lilon, Blue (with battery door)
FTN6031A	Standard battery, 800mAh, Lilon, Black (with battery door)
FTN6038A	Standard battery, 800mAh, Lilon, Blue (with battery door)
<b>Chargers</b>	
FLN9468A	Dual Pocket Desktop Charger
SPN4716B	Travel charger
SYN7455A	Plug Adapter UK for travel Charger
SYN7456A	Plug Adapter EU for travel Charger
FLN9469A	Vehicular battery charger
<b>Vehicular Adapters</b>	
FLN2850A	Car Kit
FLN9569A	Stand alone car cradle
<b>Audio accessories</b>	
WADN4184A	Headset with Boom mic and in line PTT
FLN9470A	Headset with Boom mic (On Hold)
FLN9568A	PHF
<b>Carrying Accessories</b>	
FLN9476A	Soft leather carry case
FHN6246A	Belt clip
<b>Others</b>	

**THIS PAGE INTENTIONALLY LEFT BLANK**

---

---

## General

To achieve a high spectrum efficiency, the MTH500 uses digital modulation technology and sophisticated voice-compression algorithm. The voice of the person speaking into the microphone is converted into a digital bit stream consisting of zeros (0) and ones (1). This stream is then modulated into a radio-frequency (RF) signal, which is transmitted over the air to another radio. The process is called digital modulation.

## Digital Modulation Technology

The MTH500 is a 380-400 MHz portable radio that can operate in dispatch and phone mode. This radio can also operate in TMO (Trunked Mode Operation) and DMO (Direct Mode Operation). It uses two digital technologies:  $\pi/4$ DQPSK and Time Division Multiple Access (TDMA).

$\pi/4$ DQPSK is a modulation technique that transmits information by altering the phase of the radio frequency (RF) signal. Data is converted into complex symbols, which alter the RF signal and transmit the information. When the signal is received, the change in phase is converted back into symbols and then into the original data.

The system can accommodate 4-voice channels in the standard 25 kHz channel as used in the two-way radio.

Time Division Multiple Access (TDMA) is used to allocate portions of the RF signal by dividing time into four slots, one for each unit.

Time allocation enables each unit to transmit its voice information without interference from other transmitting units. Transmission from a unit or base station is accommodated in time-slot lengths of 15 milliseconds and frame lengths of 60 milliseconds. The TDMA technique requires sophisticated algorithms and a digital signal processor (DSP) to perform voice compressions/decompressions and RF modulation/demodulation.

## Voice Compression Technology

Voice is converted into a digital bit stream by sampling the voice at high rate and converting the samples into numbers, which are represented by bits.

Voice compression reduces the number of bits per second while maintaining the voice at an acceptable quality level. The MTH500 uses a coding technique called ACELP (Algebraic Code Excited Linear Prediction). The compressed voice-data bits modulate the RF signal.

---

## Description

### Transceiver Description

All the radio circuitry is contained in the Digital/RF Board and the keypad board. The Digital/RF board is divided into the following sections: digital, frequency generating, transmitter, and receiver.

#### Digital Section Description

The digital section includes the Redcap 2 that consists of the Mcore risk machine and the Digital Signal Processor (DSP).

The Mcore is the controller of the Digital/RF Board. It controls the operation of the transmitter, receiver, audio, and synthesizer integrated circuits located in the RF section. It communicates with the keypad and display.

The Digital Signal Processor (DSP) which performs modulation and de-modulation functions for the radio. It also performs Forward Error Correction and other correction algorithms for overcoming channel errors and ACELP speech coding. It carries out linear 16-bit analog to digital conversions, audio filtering, and level amplification for the microphone audio input and the received audio output.

The power and audio section is based on the GCAP III and includes power supplies, 13-bit CODEC, audio routing, microphone and ear piece amplifiers. A audio power amplifier is used for the loud speaker.

#### Transmitter Path Description

The transmitter circuitry includes a linear class AB Power Amplifier (PA) for the linear modulation of the MTH500. It also includes a novel cartesian feedback loop to enhance its transmitter linearity and reduced splattering power into adjacent channels.



The transmitter path consists of a novel cartesian feedback loop that contains the forward and loop feedback paths. The forward path includes the low noise ODCT (Offset Direct Conversion Transmitter), Balun, Attenuator, and Power Amplifier. The loop feedback path includes the directional coupler, attenuator, and LNODCT (Low Noise Offset Direct Conversion Transmitter) ASIC.

The cartesian Feedback output power passes to the antenna through the Isolator, Antenna Switch, and Harmonic Filter.

### **Receiver Path Description**

The receiver path includes the Antenna Switch, SAW, LNA, ceramic filter, mixer, Crystal Filter, and WPIC (World Phone IC). The first IF consists of the Crystal Filter and WPIC ASIC.

### **Frequency Generating Section Description**

The frequency generating section provides description of the following main components: Fractional-N Synthesizer, REF. oscillator, Main VCO, WPIC ASIC Synthesizers, LNODCT ASIC Synthesizer, External Offset and second LO Synthesizer, DSP PLL, and Host PLL.

**THIS PAGE INTENTIONALLY LEFT BLANK**



# Theory of Operation

---

---

## Section Introduction

This section provides a block diagram overview of the main Digital/RF Board. This is supplemented by the detailed block diagram and detailed circuit description.

---

## Block Diagram Overview

The main Digital/RF Block contains the following four sections (see Figure 1). An overview of these four sections is provided in the following paragraphs:

- Receiver Section
- Transmitter Section
- Digital & Audio Section
- Frequency Generating Section (Synthesizer)

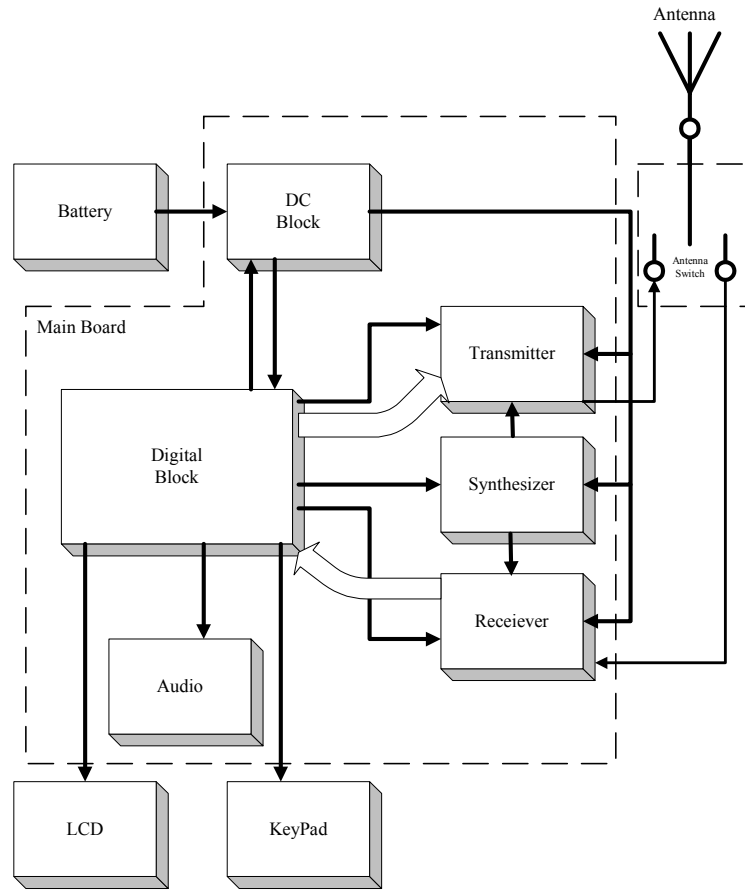

Figure 1 General Block Diagram

## Receiver Section

The receiver section includes the following main components:

- Antenna Switch
- Limiter
- Front Filter
- Low Noise Amplifier (LNA)
- Second Pre-selector
- Attenuator
- Mixer
- IF Filter
- Balun
- WPIC

The Receiver Path implements an Automatic Gain Control (AGC). It is required to maintain a good receiver linearity over a wide range of incoming signals and prevents clipping of high level signals.

The first Intermediate frequency (IF) circuit consists of the Mixer, IF Filter, and WPIC. The second IF consists of an analog IF and a digital mixer that converts to base band. They are located in the WPIC. The WPIC performs the following functions:

- Carries out amplification and quadrature down conversion of the signal into the second IF.
- Performs IF AGC.
- Converts the second IF analog signal into digital I & Q formats.
- Synthesizes the second VCO frequency.
- Synthesizes the Sigma-Delta clock.
- Synthesizes the receive and data transmit data clock.
- Transmits the received data to the DSP.

## Transmitter Section

The transmitter circuitry includes a linear class AB Power Amplifier (PA) for the linear modulation of the MTH500. It also includes a novel cartesian feedback loop to enhance its transmitter linearity and reduced splattering power into adjacent channels.

The transmitter path consists of a novel cartesian feedback loop that contains the forward and feedback paths. The forward path includes the low noise ODCT (Offset Direct Conversion Transmitter), Balun, Attenuator, and Power Amplifier. The loop feedback path includes the directional coupler, attenuator, and LNODCT (Low Noise Offset Direct Conversion Transmitter) ASIC.

The cartesian Feedback output power passes to the antenna through the Isolator, Antenna Switch, and Harmonic Filter.

## Digital Section

This section includes the REDCAP2, which controls the transmit, receive, and synthesize operations of the integrated circuits located in the RF section. Within the REDCAP2 is the DSP and the serial communication interface.

The digital section contains the following:

- REDCAP2
- Power On/Off circuitry
- Serial peripheral interface (SPI)
- Host memories (flash and SRAM)
- Bottom connector signal MUX
- Keypad block and connector
- LCD (liquid-crystal display) circuit and connector

## Frequency Generating Section

The frequency generating section contains the following components:

- REF. Oscillator - TCXO
- Main Synthesizer - consists of the WPIC's PLL and the Main Voltage Controlled Oscillator (VCO).
- 2nd Local Oscillator (LO) VCO together with the LMX Dual Synthesizer.
- Offset VCO together with the LMX Dual Synthesizer.

## Block Diagrams Descriptions

The block diagrams descriptions cover Receiver Path, Transmitter Path, Digital Section, and Frequency Generation Section.

### Receiver Path

The received signal (see Figure 2) from the antenna is directed by the Antenna Switch to the Front Filter.

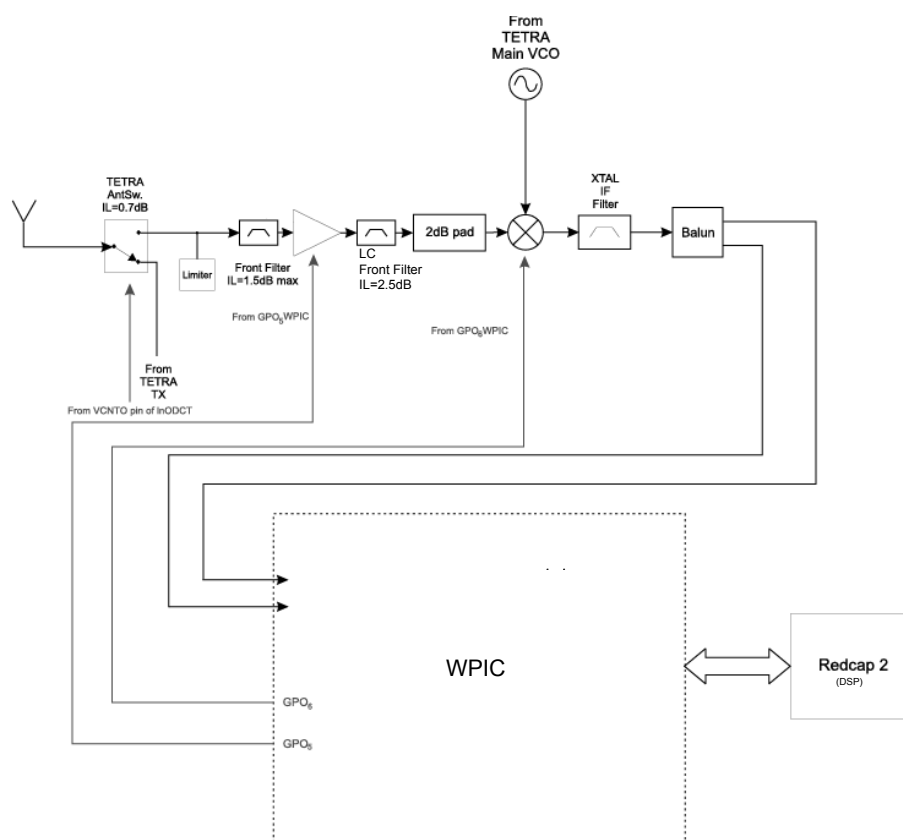

Figure 2 Receive Path Block Diagram

This block-type filter, which defines the receive frequency range, blocks the half IF and image frequency entry, and reduces the RF oscillator leakage. The signal is mixed with the local oscillator to create the first IF at 109.65 MHz. The signal is filtered by the crystal filter and sent to the WPIC ASIC.

The WPIC performs down conversion to the second IF at baseband frequency (0 Hz) and converts the second IF analog signals into digital-in-phase (I) and Quadrature (Q) formats. This

data is sent for further processing to the Digital Signal Processor (DSP) (part of RedCap2) over the Synchronous Serial Interface (SSI) data links.

The DSP performs: the demodulation, Forward Error Correction (FEC) and other correction algorithms for overcoming channel errors, and the GCAP decoder procedure for digital speech data decompression.

### Transmitter Path

When the radio is transmitting (see Figure 3), the microphone audio is sent to the GCAP (CODEC). The CODEC performs analog-to-digital conversion and the digital signal is routed to the DSP. The DSP performs coding, Error Correction and modulation. From the DSP, the signal is sent to the WPIC+.

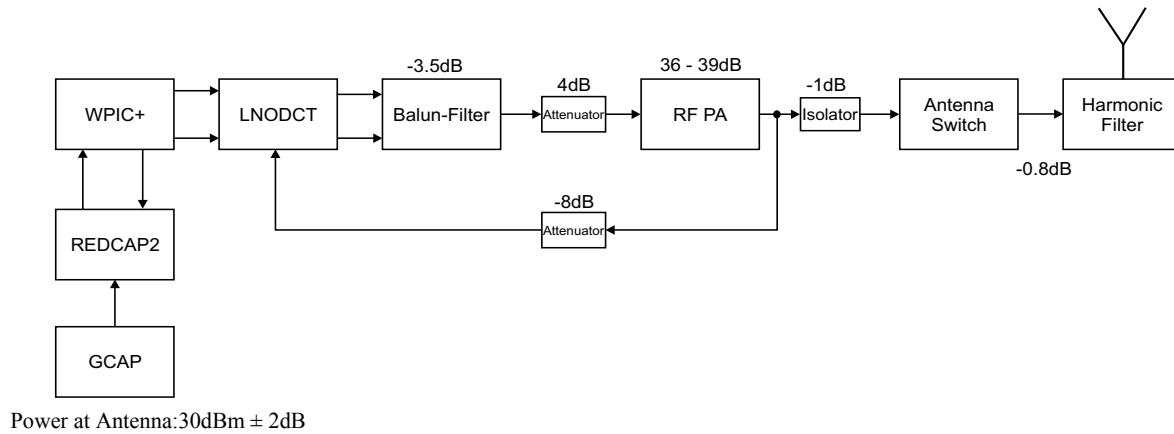

Figure 3 Transmit Path Block Diagram

In the WPIC+ data is converted into analog signal. This signal is also filtered. From the WPIC+, the data is injected to the LNODECT. In the LNODECT the data is mixed with RF signal.

From the differential output of the LNODECT the modulated RF signal is injected to the Balun-Filter, that transforms the differential input into single output, and then it is routed to the antenna via the Antenna Switch.

The feedback signal is used for power control.



## Digital Mode of Operation

The digital section (see Figure 4) contains the radio's Redcap Risk-processor with its external memory and DSP, including its memory, within. GCAP III includes switching regulator and linear regulators, audio preamplifiers, CODEC 13-bit, 8-channel 8-bit A/D Converter, Regulators, Audio Amplifier.

The Redcap controls the receive/transmit frequencies, power levels, display, keypad, accessories, MMI, and other radio functions. This microprocessor can be operated through the RS232 interface by a personal computer to program the FLASH.

The codec distribution is supported by the Global Control Audio Power (GCAP III) IC. This IC supplies power to the radio using step-down PWM regulator supplying 1.88 VDC to the Redcap core, V3 linear regulator 2.775VDC to the external memories, display and Redcap peripheral modules, supplying V2 to the A/D converter, GCAP internal logic, and audio amplifier. The regulator's power-down mode is controlled by the redcap, which senses the ON or OFF condition.

The DSP performs signalling, and voice encoding and decoding. The audio filtering and volume control, and analog-to-digital and digital-to-analog conversions on audio signals, are performed in the GCAP's Codec.

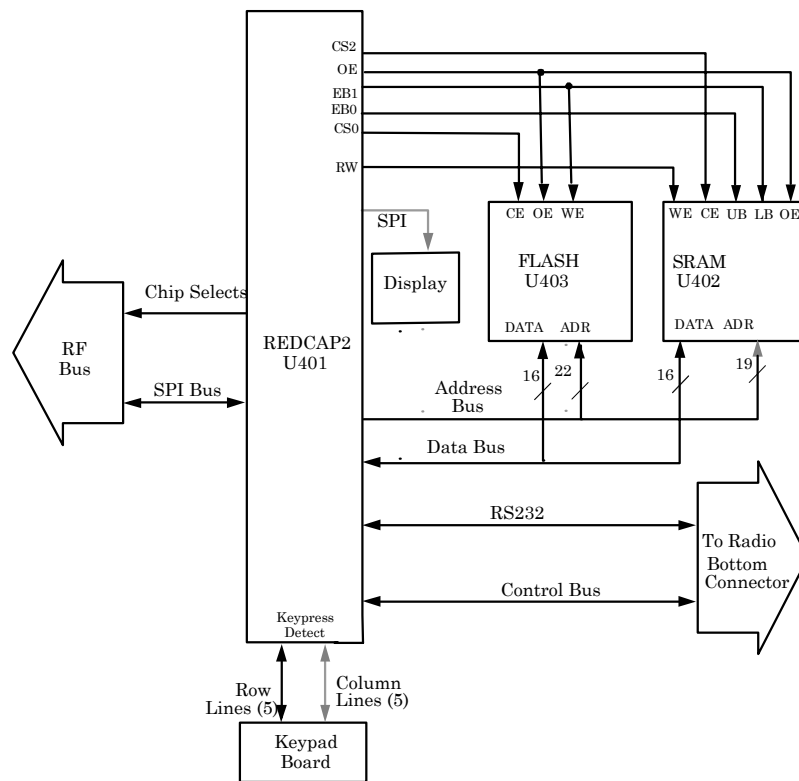

Figure 4 Digital Section Block Diagram

## Frequency Generating Section

The frequency generating section contains the following components (see Figure 5):

- REF. Oscillator - TCXO
- Main Synthesizer - consists of the WPIC's PLL and the Main Voltage Controlled Oscillator (VCO).
- 2nd Local Oscillator (LO) VCO together with the LMX Dual Synthesizer.
- Offset VCO together with the LMX Dual Synthesizer.

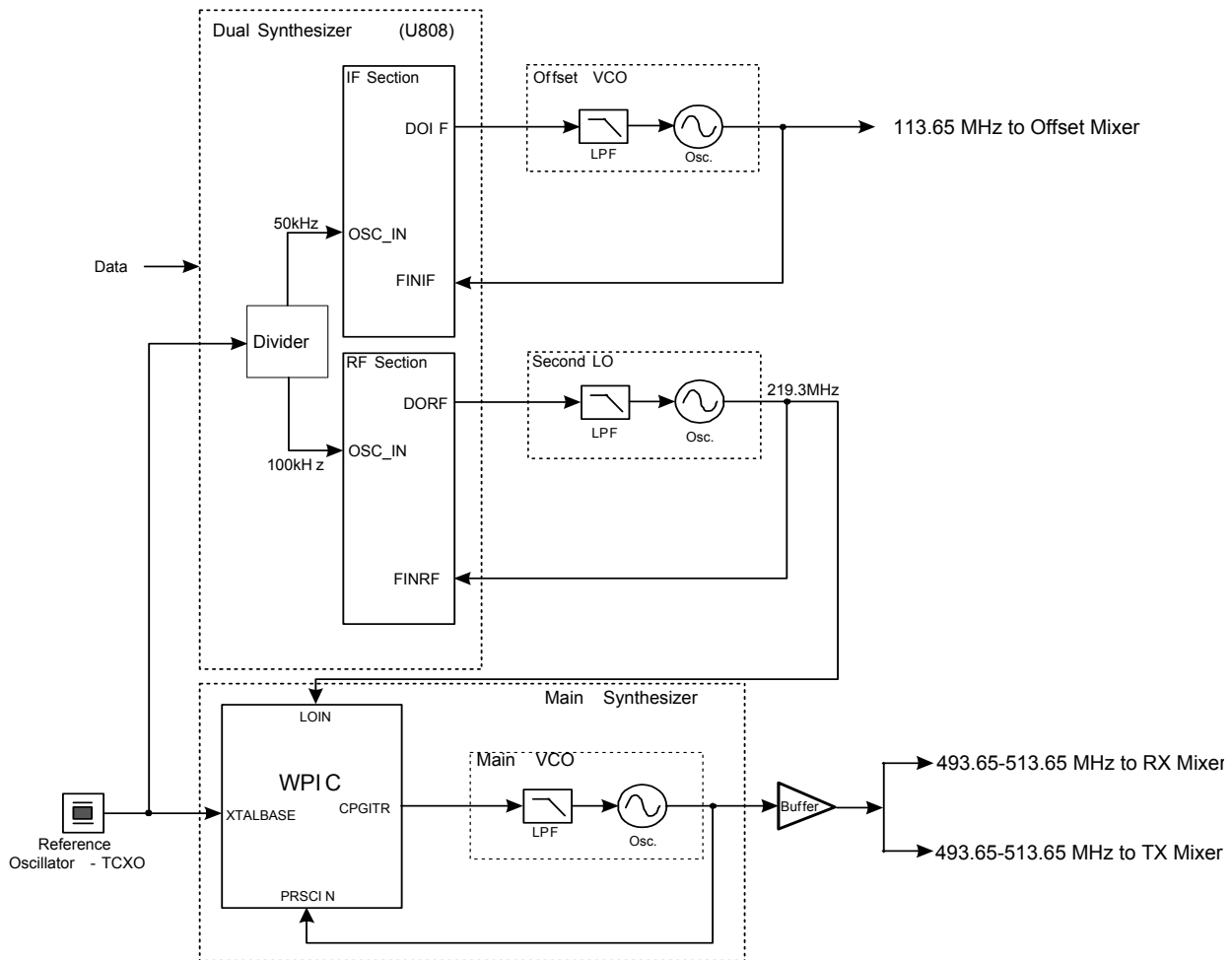

Figure 5 Frequency Generation - Block Diagram

All frequencies originate from the REF. oscillator -TCXO. This is a digital temperature compensated crystal oscillator producing an accurate and stable 16.8 MHz reference frequency. The 16.8 MHz reference frequency is divided in the WPIC and in the Dual Synthesizer to produce required reference frequency for the other synthesizers.

### **Main Synthesizer**

The Main Synthesizer consists of the WPIC internal PLL modules, and Main VCO on board. It produces the LO signal to down-convert the receive signal to the first IF 109.65 MHz frequency and to up-convert the 113.65 MHz transmitter IF frequency to produce the RF carrier frequency.

### **RX Second Local Oscillator (LO)**

The second LO synthesizer supplies the second IF local oscillator frequency to the receiver. It produces 219.3 MHz that is divided by two in the WPIC in order to down-convert the received signal to the baseband.

### **Offset VCO**

The Offset VCO consists of the LMX Dual Synthesizer and the VCO on board. It produces the output of the offset VCO 113.65 MHz.

## Detailed Circuit Description

### Receiver Path, Detailed Circuit Description

See Figure 6.

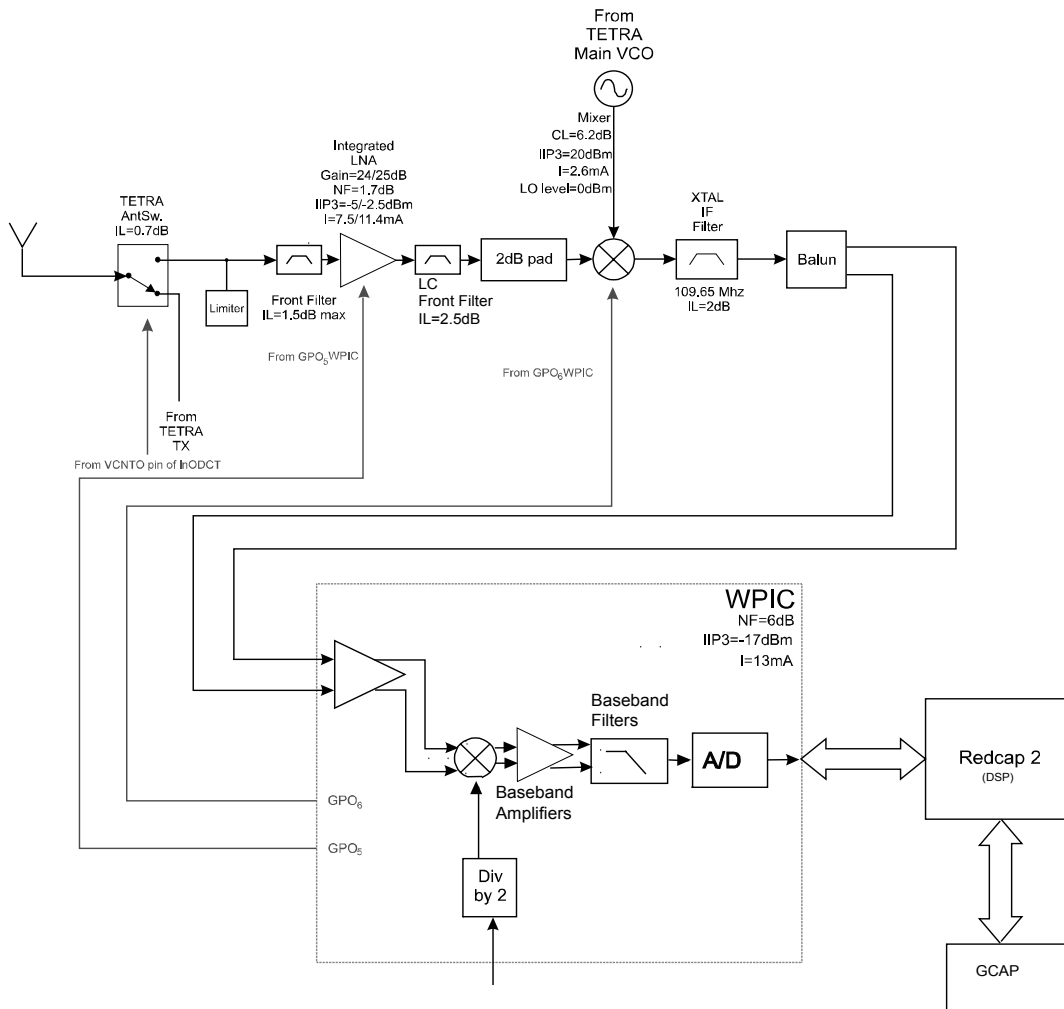

Figure 6 Receiver Path Circuit Diagram

### Antenna Switch

The signal coming from the antenna is routed to the receiver section via the harmonic filter, which is comprised of L890 and C1012. The signal continues to flow through image filter (equivalent quarter wave) transformer C1015 and L817 to the Rx section toward limiter diode D500. The antenna switch attenuates the image

frequency by approximately 38dB. The attenuation of wanted signal is typically 0.7dB.

### **Limiter**

The limiter (D500) function is to prevent entering of signal with power higher than 30dBm, which may damage the receiver front-end.

### **Front Filter**

The signal arrived from the limiter is flowing via the front filter (FL500) and routed to the Low Noise Amplifier (LNA) (U500) via C576.

The front filter is also called -1st pre-selector and is used to attenuate the incoming parasitic RF frequencies, especially the image frequency (25dB). The Insertion Loss (IL) is typically 2dB.

### **LNA**

The LNA module is the RF signal amplifier. The LNA gain (U500) including output matching circuit, C1048, L518, C521, R965, L500, C532, R580 and C507, is typically 23dB. Because the LNA is the first amplifier in the line, it is important that it will maintain large gain and small Noise Figure - 1.8dB.

The LNA has an “enable” pin (pin 3) which is called VPD. When this pin receives a supply of 1.8 V from DC switch (Q504) - the amplifier is enabled. From the LNA the signal passes to second pre-selector, LC filter (FL501). The IIP3 of the LNA is between -5dBm to -2.5dBm.

### **Second Pre-selector**

The 2nd Pre-selector (FL501) attenuates the non-linear products of the LNA and also the image product by 25dB. Its IL is typically 2.5 dB. From the output of the LC filter the received signal is routed via a Pi-attenuator to the Mixer RF input.

### **Attenuator**

The purpose of the resistor Pi-attenuator (R519, R517, R945), is to protect the mixer (U504) input from saturation. The pad attenuates RF power by 2.5dB

### **Mixer**

The Mixer (U504) function is to down convert the incoming RF signal into IF signal (109.65 MHz). The Conversion Loss (CL) is typically 6.2dB and its IIP3 is typically 20dBm.

The RF signal enters the Mixer at pin 1, and the IF is produced at pin 6. The LO (from the main VCO) signal passes via the matching circuit (C522, L505, R943

and C984), enters the Mixer at pin 3. The LO power at the LO mixer input is -2dBm. The 2.7V DC is supplied by switch Q500 to pin.4.

The mixer conversion Loss is 7dB.

An impedance matching net is placed between the mixer and the IF filter (FL502). It consists of L512, C525, C531, C524, L504 and C539.

### **IF Filter**

The IF signal is routed via the IF filter (FL502), which has IL of 2.5dB and attenuates parasitic products of the Mixer, and via an impedance matching network that consist of C546, C536 and L501 to the BALUN.

### **BALUN**

The Balun transforms the single ended input RF signal to a differential double-ended output. It consists of L519, C526, C527, L520, C530 and C534.

The differential signal is routed to the WPIC (Word Phone IC) at pin A4 and B4.

### **WPIC (receiver section)**

The differential IF signal is amplified and transferred into the WPIC and mixed with 2nd LO signal. The 2nd LO signal is routed to the WPIC at pin D1 and divided by 2 in to the quadrature generator block of the WPIC. The baseband signal from the mixer passes via a Baseband filters and amplifiers arrays that gives lower noise and better I & Q balance, to the WPIC A/D block and than to the DSP.

An internal AGC that is controlled by a control unit, establishes an appropriate attenuation for unwanted signals as well as an appropriate gain for wanted signals. The voltage at external capacitor C557 indicates the AGC attenuation level for the different input signal levels. The voltage at the capacitor varies from 1.4V to 2.7V as a function of the power of the received signal.

## Transmitter Path, Detailed Circuit Description

See Figure 7.

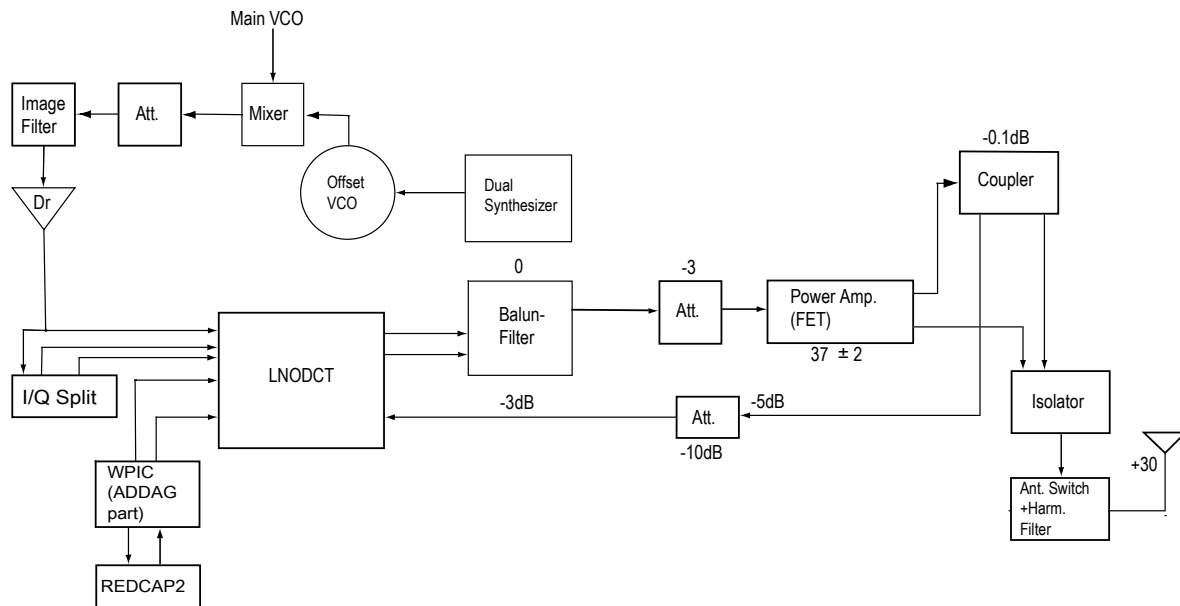

Figure 7 Transmit Path Circuit Diagram

## Forward Path

### WPIC

The WPIC (World Phone IC) U503 receives serial data that is transmitted by the REDCAP2 at a 48 kbps rate to the SSI port (pin K10, STD). Data is transmitted as a 16-bit 'I' word followed by a 16-bit 'Q' word. The WPIC provides a serial clock of 4.8MHz to the REDCAP2 (pin K11, TXCLK) and sends a frame sync signal (pin L11, RXFS/SFS) at the beginning of every 'I' word transmission, to instruct the REDCAP2 to send data. In the WPIC, the received serial I & Q words from the REDCAP2 are converted into parallel I & Q words, and transferred to an interpolating filter. The interpolating filter increases the sampling rate to reduce in-band quantization noise, as well as to reduce image at multiples of the input data. The interpolated samples are rounded to 8 bits, and run through the 8-bit D/A converters. The D/A converters take the digital I & Q words and convert them into analog signals, which are filtered and amplified. The output is comprised of two separate low-level differential signals, I & Q (pins A8, OUTQ; C8, OUTQB; D8, OUTI; A9, OUTIB). A differential output is used to minimize the noise pick-up, due to its inherent common mode rejection. The output signals are routed to the LNODCT IC where the transmitting loop is closed. The WPIC sends a 2.4MHz

low-level differential reference clock signal (pins B11, TCLCK; C10, TCLCKB) to the LNODCT. It also sends a differential signal (pins A11, TSLOT; A10, TSLOTB) that marks the beginning and the end of each transmission time slot of the REDCAP2 (whenever a TXE signal (pin H8 TXE) is received from the REDCAP2). After receiving the TSLOT signal, the LNOC DT toggles the ASW line (pin J5, ASW) which signals the WPIC to set VCNT0 signal LOW (pin J6, VCNT0) which enables the Antenna Switch during transmit time. WPIC starts to receive data from REDCAP2 after TXE signal (pin H8, TXE).

### LO LINE-UP

LO LINE-UP includes MIXER U800, Attenuator (R800, R819, R808), Image Filter FL800, LO Driver Q808, and I - Q Splitter Q801. Offset VCO is based on Dual Synthesizer IC U808 that receives data from REDCAP2 that defines Offset VCO parameters. The Offset VCO signal 113.65MHz is mixed with the Main VCO signal (493.65 - 513.65MHz) in the Mixer U800. The output of the Mixer is the RF carrier frequency. The signal passes through the  $\Pi$ -attenuator and image filter FL800. The image filter attenuates the VCO and image frequencies and any out-of-band spurs that may be present. The signal is amplified by LO FET Driver Q808 and routed to I-Q splitter U801 that converts the single input signal into two quadrature (90 degrees phase shift) 'I' and 'Q' signals and then routes them to the LNODCT LO input (pins 46, LOQ; 45, LOQB; 57, LOI; 56, LOIB). RF signal is sampled at the I-Q splitter input and applied to the LNODCT LO feedback (pin 24, MVCO).

### LNODCT

The LNODCT (Low Noise Offset Direct Conversion Transmitter) U803 is the heart of the transmitter.

The differential base-band signals from the WPIC are inputted into the LNODCT on pins 58 – 61 (BINQB, BINQ, BINIB and BINI). They pass through a variable attenuator and then they are summed with the down converted I & Q feedback. The base-band signal is then amplified and sent to the up-mixer.

The up-mixer consists of two mixers, one for the I channel and the other for the Q channel. The split I & Q LO signal is mixed with the base-band I & Q signals to produce an I and Q modulated signals at RF frequency. The signal is then output differentially on pins 51 and 52 (RFOUTB, RFOUT).

### BALUN - FILTER

The differential RF signal is converted to a single-ended (unbalanced) signal by passing the BALUN-Filter FL801 (balanced-unbalanced filter). The BALUN-Filter has a 200 Ohm input and 50 Ohm single-ended output, the BALUN-Filter output voltage amplitude is two times higher than the differential voltages amplitudes. Thus the LNODCT output signal is increased by 6dB in compare to each of the differential signals.



Another function of the BALUN-Filter is to attenuate the image frequencies and other unwanted out-of-band spurs present in the output signal. The insertion loss of the BALUN-Filter is 3dB. The output signal from the BALUN-Filter is applied to the RF PA through -1.8dB attenuator (R836, R833, R834).

### RF Power Amplifier

The signal is then routed through DC coupling capacitor C823 to the RF Power Amplifier (PA). The PA IC consist of two amplifying stages. The PA output is matched with 50 Ohm coupler by the  $\Pi$ -LC-circuit (C1028, C1029, L921). LC notch filter (L923, C1030) rejects the second harmonic of the RF signal. The PA gain is set by PA\_BIAS voltage from the REDCAP2, L1T 3 (pin C6, TOUT3). The bias voltage is applied to the dual-transistor switch Q807, Q911 and then to PA (pins 8, VREG; 16, VBIAS respectively).

### Coupler and Feedback Path

A coupler U806 exists at the RF PA output, it is used to pass the signal to Isolator FL801 and sample the signal thus providing the necessary feedback for the linearization and feedback correction. The sampled signal is routed via attenuator R815, R818, R825 to the LNODCT (pin 37, RFIN). The feedback signal is then mixed down to base-band in a quadrature down mixer, amplified and summed with the base-band input signal. The loop is closed.

### Isolator

The signal in the forward path is fed to pin 2 of the isolator (FL801). The isolator is placed at the PA output to decrease the influence of the antenna impedance variation on the PA performance. The reflected power returned from the antenna, is absorbed in a 50 Ohms resistor inside the isolator. The isolator also protects the Cartesian loop from sudden VSWR variations that could lead to loop instability.

### Antenna Switch

The RF signal from the Isolator is applied to the PIN DIODES U802. The PIN diodes are turned on during the transmission time slot, and the DC current flows through the Isolator to the ground. The RF signal is routed through 2  $\Pi$ -LC-circuits (C848/L818/C838 and C1010/L817/C852) and the Harmonic Filter to the Antenna. L817/C1015 circuit provides the image rejection of the output RF signal. In the Receiving mode the PIN diodes are turned off, the input RF signal is directed to the receiver path via p/4 LC equivalent circuit (C1010/L817/C852). The condition of the PIN diodes is controlled by the voltage switch Q806 by applying the ANT\_EN signal to the switch. The resistor R832 determines the DC current through PIN diodes; diode D801 provides the additional capacitance during the Transmission mode, capacitors C835 and C832 compensate the parasitic inductance of the D801. The VCNT0 signal applied to the voltage switch Q806 is set LOW during the Receiving and Transmission modes.

The RF output signal is disabled during the CLCH (Training) mode by setting the VCNT0 signal HIGH thus providing the low output power during the training slot.

### Harmonic Filter

From the antenna switch the signal is routed to a one section of LC filter, consisting of the coil L890 and capacitors C1010, C1011 and C1012. The filter is required to attenuate the harmonics of the amplifying stages at the transmission path, and the Local Oscillator leakage at the receiver path.

## Digital Section, Detailed Circuit Description

See Figure 8.

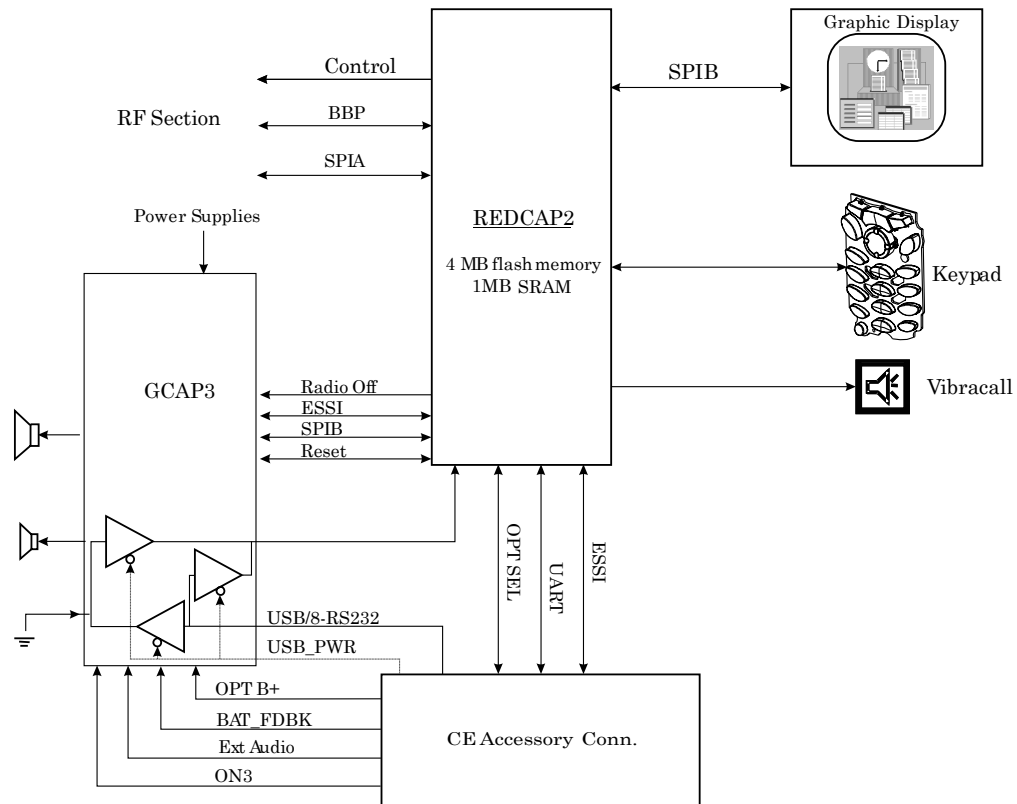

Figure 8 Digital Section - Detailed Circuit Diagram

### Host Memories

The RedCap2 Address bus is a 22-bit wide (0:21) and RedCap2 Data Bus is a 16-bit wide (0:15).

RedCap2 uses two types of memories:

#### Flash Memory

The Flash Memory is dedicated to the application software. This memory has a 16-bit wide data bus. The Flash memory location has a 32M Bit of memory; When addressing the Flash memory location, the processor reads into its 16-bit wide data bus.

The Flash also stores the Radio CodePlug (Customer related information) such as telephone numbers, addresses, etc.

### **SRAM Memory**

This 512 x 16 Static Ram is used for Data storage.

### **Serial Peripheral Interface (SPI)**

The RedCap2 uses the SPI protocol (Serial Peripheral Interface) to communicate with RF IC's (WPIC, ODCT, Synthesizer/LMX), GCAP3 IC and the display driver.

The RF IC's are connected to SPIA module, while GCAP3 and the display are connected via SPIB module.

The protocol is built upon 4 lines [MOSI(Tx), MISO(Rx), CS, CLK)].

The Display Module, based on the display driver (i.e. Samsung KS0741) uses a serial interface.

Figure 9 is a block diagram of the RedCap2 and its interfaces.

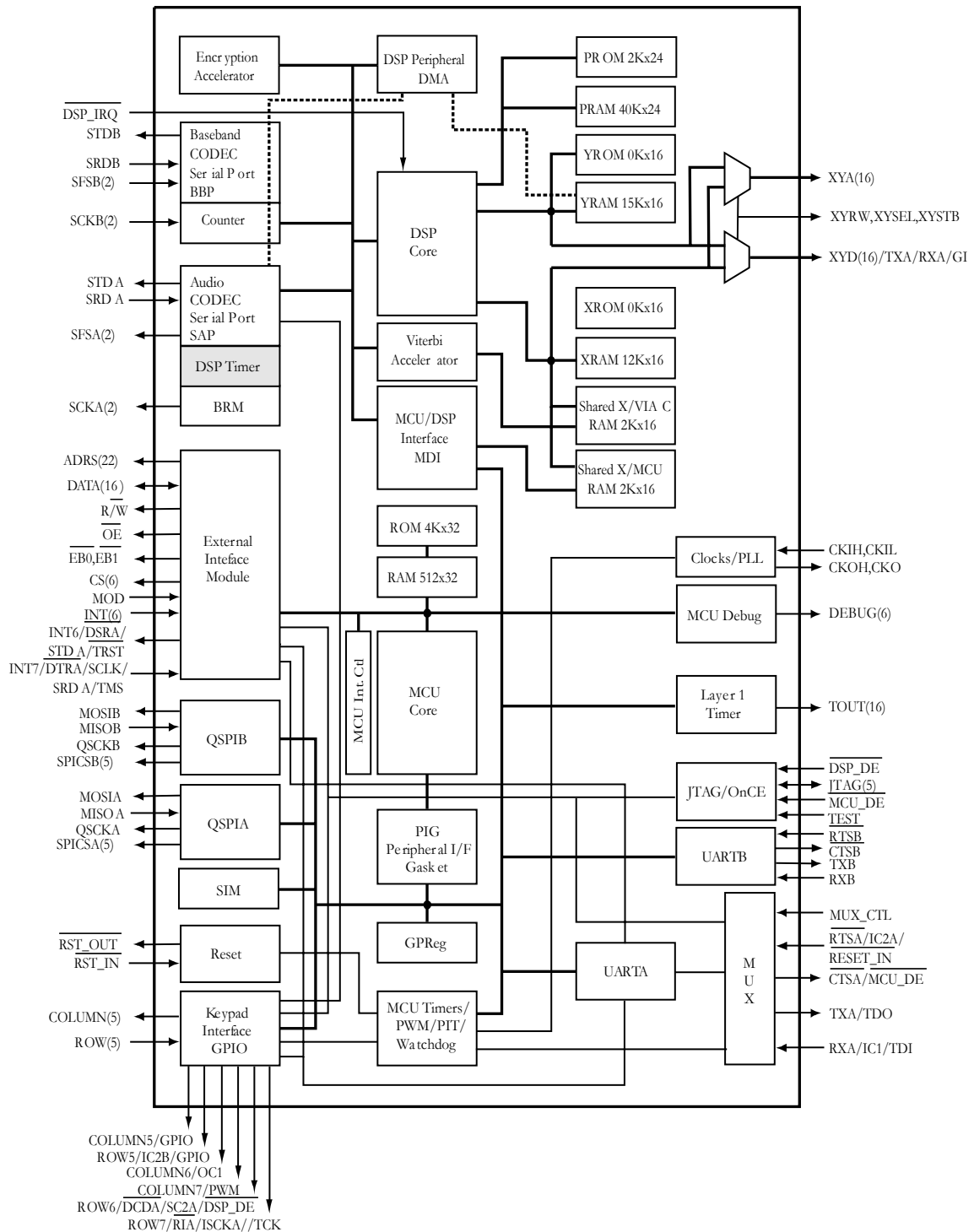

Figure 9 REDCAP2 Block Diagram

## DC Power Distribution

(See Figure 10).

### V1 Linear Regulator

V1 is a programmable linear regulator. It is programmed using the Redcap SPI bus from 0.975V to 3.0V in 8 steps. This regulator is active during Power Reset (POR) and its initial value is 0.95V. For this radio, V1 (programmed to 1.875V) is the supply for the vibrator motor. This regulator is active whenever the radio is turned ON.

### V2 Linear Regulator

V2 is a selectable linear regulator. It is selectable using the GCAP UV\_SEL pin between either 2.5V and 2.775V. This regulator is active during POR and its initial output value is set by GCAP3 UV\_SEL pin. Connecting UV\_SEL pin to B+ sets V2 output value to 2.775V, connecting UV\_SEL pin to Ground sets V2 output value to 2.5V. For this radio, V2 is selected to 2.775V. This regulator is supplied by B+ and it is active whenever the radio is turned ON. V2 is the supply for internal and external audio circuits, CLK\_IN input driver and TS interface.

### V3 Linear Regulator

V3 is a selectable linear regulator. It is selectable using the Redcap SPI bus from 1.875V to 2.775V in 4 steps. This regulator is active during POR and its initial output value is 2.775V. For this radio, V3 is selected to 2.775V. The regulator is supplied by B+ and it is active whenever the radio is turned ON. V3 is V3\_2.775V, which is the supply for the SRAM, FLASH, Redcap, CE bus and Display.

### V4 Linear Regulator

V4 is a selectable linear regulator with external pass transistor. It is selectable using the Redcap SPI bus from 1.875V to 2.775V in 4 steps. It is set to 2.775V. V4 is always powered from B+ and it is active whenever the radio is turned ON. This regulator is active during POR. V4 is V4\_2.775V\_RF, which is the supply for the WPIC, ODC T and LMX.

### Switcher #1 (Synchronous Buck Mode Converter)

Switcher #1 is a selectable step down switching regulator. It is selectable using the Redcap SPI bus from 1.2V to 2.45V in 6 steps, Pass Through and Power down modes. The switcher is active during POR in 1.86V mode. It is set to 1.86V. Switching regulator is PWM#1\_1.86V, which is the supply for the internal core, emulation port and clock output drivers of the Redcap. The switcher is supplied from B+ and it is active whenever the radio is turned ON.

## Switcher #2 (Boost Mode Converter)

Switcher #2 is a selectable step up switching regulator. It is selectable using the Redcap SPI bus to 5.6/5.0/3.35 Volt and Power down mode. The switcher is supplied from B+ and it is active whenever the radio is turned ON. The switcher is inherently in 5.6V mode at POR. The radio uses the switcher at 5.6 V to supply 5V\_RF and VSIM linear regulators.

## DSC Linear Regulator

DSC is a fixed output linear regulator. This regulator is active during POR in the 5V mode. DSC is supplied from PWM#2\_5.6V, which is used to supply the WPIC and ODC1 charge pump circuits.

## TS\_REF Linear Regulator

TS\_REF is a fixed output linear regulator. It is supplied internally from the V2 linear regulator. It is set to 2.3V. The radio uses TS\_REF for the AD voltage dividers. It is not active at POR.

## VREF1 Linear Regulator

VREF1 is a programmable linear regulator. It is programmed using the Redcap SPI bus from 1.875V to 2.775V in 4 steps. This regulator is active during POR and its initial value is 2.775V. For this radio, VREF1 is programmed to 2.775V and is battery supplied. VREF1 is VREF1\_2.775V, which is the supply for TCXO.

## VREF2 Linear Regulator

VREF2 is a programmable linear regulator. It is programmed using the Redcap SPI bus from 1.875V to 2.775V in 4 steps. This regulator is active during POR and its initial value is 2.775V. For this radio, VREF2 is programmed to 2.775V and is battery supplied. VREF2 is VREF2\_2.775V, which is the supply for the keypad and display backlight circuits. This regulator is On whenever the radio is turned ON.

## Current Limit

The SWB+ current limit regulator provides power from the phone battery to clip-on accessories. It is enabled only when the phone is powered up and an accessory which requires power from the phone is connected.

Several sections of the radio are connected directly to the battery, which supplies Raw\_B+ and Fused\_B+. The radio operates with a low-level battery voltage of 3.15Vdc, nominal-level voltage of 3.6Vdc, and high-level voltage of 4.2Vdc. The battery is connected to P1 - 4 (+) and P1 - 1 (-). These pins supply the Raw\_B+ to the RF TX power amplifier. The SWB+ output of the U104 regulator supplies the accessories through the bottom connector. Raw\_B+ is routed via F600 (Fuse)

becoming FIIIT\_B+, which goes via the main FET and provides power to the GCAP III IC.

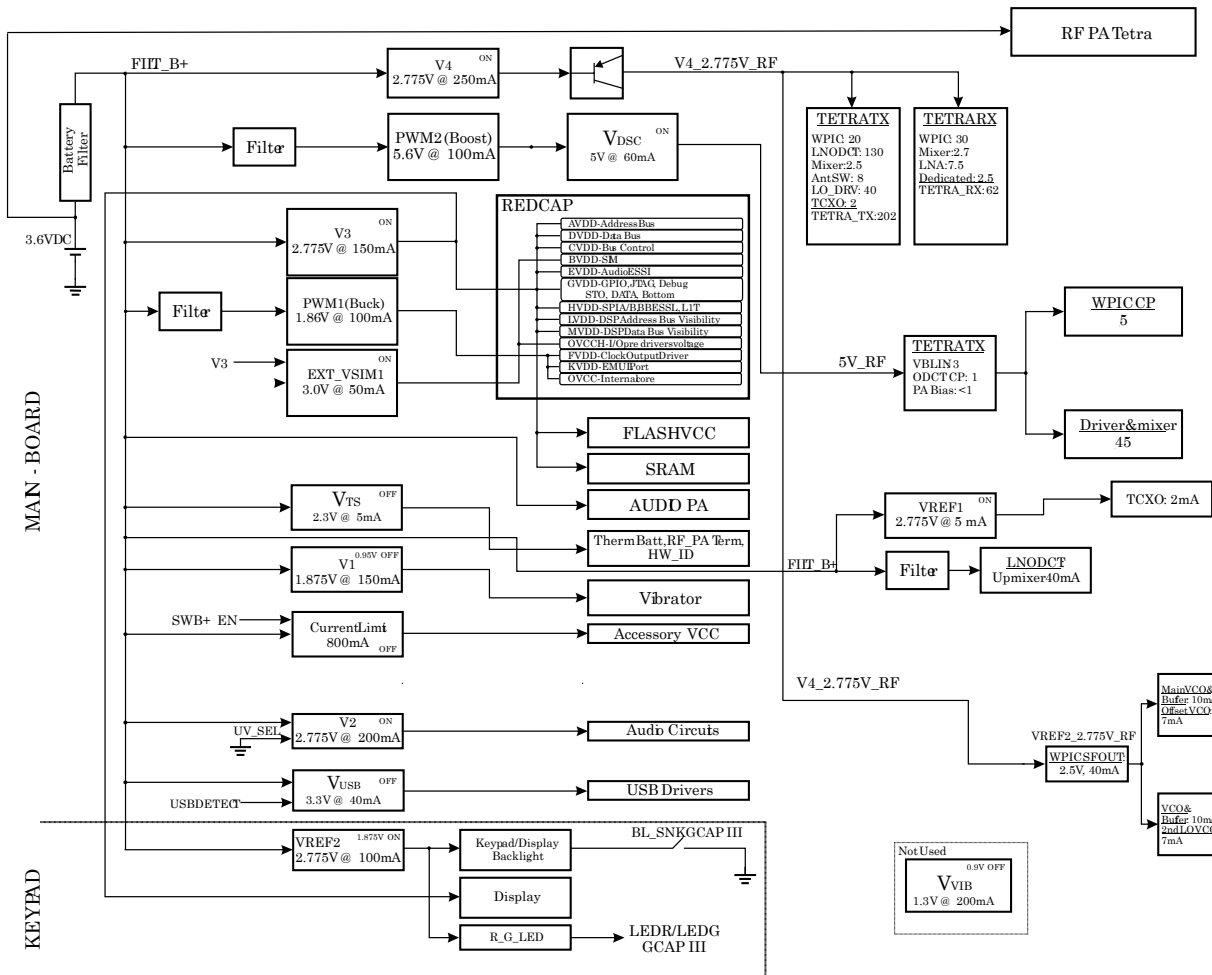

Figure 10 MTH500 DC Distribution



## RS232, SB9600

The REDCAP processor (RCE) uses the three serial protocols: UART and SB9600 to communicate with external devices via the bottom connector of the unit. There is no external hardware for switching from one protocol to another because the REDCAP2 handles the switching and line multiplexing functions internally.

## Battery ID

The battery is equipped with a Dallas 2502 EPROM. A one-wire serial bus allows the radio or the battery charger to communicate with the battery and identify whether or not the battery is compatible. If the battery is determined to be incompatible, the unit automatically shuts off, and the charger does not enter charging mode.

Besides compatibility data, the EPROM also stores the following information: battery type, capacity, fuel-gauging parameters, and voltage threshold.

## Radio Audio System

See Figure 11.

The audio system consists of the GCAP 3 IC (U600) and the DSP (U401), both are located on the main board.

The GCAP 3 perform the analog task and part of the digital task of the audio system.

### Tx Path

Audio speech is fed either to the internal microphone, or to a Phone Hands Free (PHF) microphone. The signals reach the GCAP 3 IC. In the GCAP 3 IC, a fix gain amplifier (A3 or A5) provides the signal amplification, the multiplexer (MUX) selects the active input, and the programmable Gain Amplifier (TxPGA) adjust the path gain according to the radio mode of operation. Finally, the A/D converts the analog signal into digital format and transfers it to the DSP. The DSP performs the functions of audio filtering, ACELP speech compression, digital modulation, and transfers the data to the RF section. When the radio is operating in the telephone interconnect mode, the DSP performs the required tasks such as echo and noise reduction.

### Rx Path

The digital output signal from the receiver is fed to the DSP which performs the functions of digital de-modulation, ACELP speech de-compression, and audio filtering. It transfers the data to the GCAP3 IC. In this IC, the D/A converts the digital audio format to an analog signal, the Programmable Gain Amplifier (RxPGA)

adjusts the path gain according to the setting of the volume control, and the multiplexer routes the audio to the active receive path. When the internal speaker is active, the audio is fed to A2, double-ended audio power amplifier. Otherwise, the audio is fed to A1, output amplifier, that drives the Internal Earpiece or the PHF earpiece.

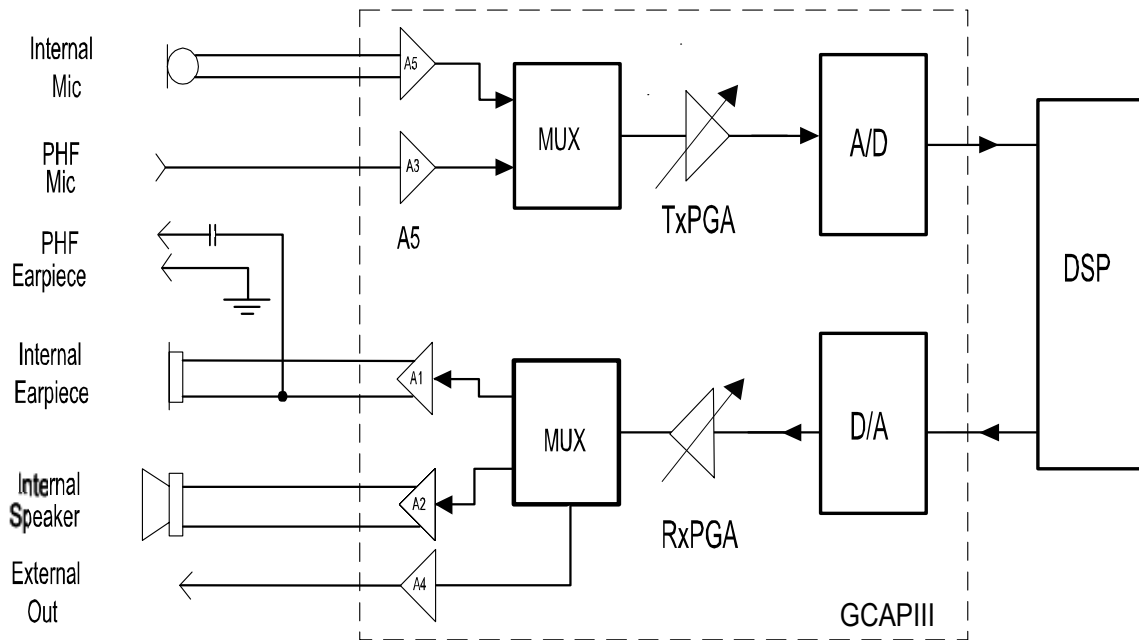

Figure 11 Audio Path Block Diagram

## Frequency Generating Section Detailed Circuit Description

See Figure 12.

This section describes the generating circuits that supply all the required frequencies for the required transmitter and receiver functions. These circuits are described as follows:

- REF. Oscillator - TCXO.
- Main VCO and Main Synthesizer.
- Second IF VCO and Dual Synthesizer RF section.
- Offset VCO and Dual Synthesizer IF section.

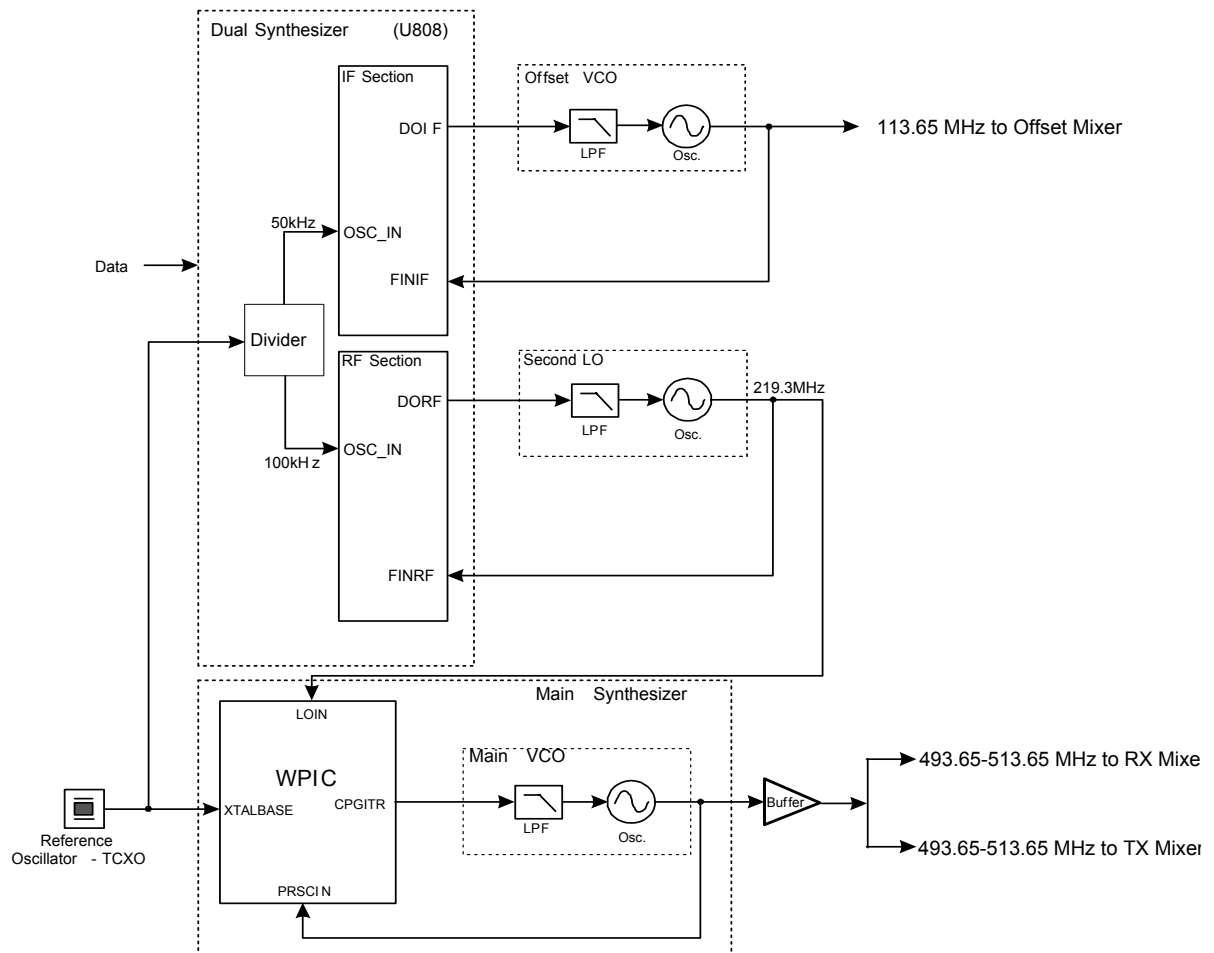

Figure 12 Frequency Generating Section - Block Diagram

## REF. Oscillator - TCXO

The TCXO is the reference frequency source for all the radio synthesizers. The output of the oscillator is a 16.8 MHz stable temperature compensated reference clock. This signal is present at pin 3 of the TCXO. This oscillator's centre frequency is programmed (256 steps of approximately 0.1 ppm). It drives the TCXO buffer to split the 16.8 MHz signal to the WPIC, LMX Dual Synthesizer and GCAP III.

The 16.8 MHz signal from pin 3 of the TCXO is routed into the following:

1. The WPIC via C580 to pin K6 XTALBASE. The signal is divided by 4 to produce the 4.2 MHz reference signal, which is used for the Main PLL synthesizer.
2. The LMX Dual Synthesizer via C946 to pin OSC\_IN. The signal is divided to produce the 100 KHz reference signal for the second LO and to 50 KHz reference signal for the Offset VCO.

## Main VCO and Main Synthesizer

The synthesizer components are WPIC, Loop Filter, VCO and buffer. It produces the LO signal.

The synthesizer functions are as follows:

- To serve as the local oscillator for the mixer of the receiver. It is used to down-mix the RF frequency (109.65 MHz).
- To serve as the LO for mixing the transmitter IF frequency (generated by the Offset VCO) into the transmit RF band. The transmitter Offset VCO frequency is 113.65 MHz. This conversion is performed in the Tx Mixer.
- To serve as the WPIC feedback signal for locking the main synthesizer.

The WPIC is programmed by the DSP through the SPI bus.

## WPIC

The WPIC contain internal synthesizer loops:

1. The main PLL is a three accumulators, fractional N system with a 24-bit resolution. The 16.8 MHz signal from pin 3 of the TCXO is routed via C580 to pin K6 of XTALBASE input of the WPIC. In the synthesizer, the signal is divided by 4 to produce the 4.2 MHz reference signal used for the main PLL synthesizer.
2. The second LO generator, which has a single ended signal at twice the desired IF frequency. The signal is routed as a differential signal (I, Q) to a quadrature phase splitter at the WPIC. The quadrature generator is a single master-slave flip-flop configured in a divide by two toggle mode.

## LMX - Dual Synthesizer

The LMX233XL is an integrated dual frequency synthesizer that includes prescalers. It is used with the second LO at the RF section and with the Offset VCO at the IF section.

The LMX uses the 16.8 MHz from the TCXO for both synthesizers and divides the TCXO frequency as follows:

- The reference frequency for the second LO is 100 KHz.
- The reference frequency for the Offset VCO is 50 KHz

## Second LO VCO

The Second LO VCO is a discrete VCO that is controlled by the LMX Dual Synthesizer RF section. The VCO produces a frequency of 219.3 MHz.

The internal phase detector is of the charged pump type.

The output signal of the of the VCO is routed via the phase detector at U808, pin 5 (FINRF).

The output of the phase detector is present at U808, pin3 (DORF) and than via the loop filter R915, C903, C948.

## Offset VCO

The Offset VCO is a discrete VCO that is controlled by the LMX Dual Synthesizer (U808) IF section. The Offset VCO produces frequency of 113.65 MHz.

The internal phase detector is of a charged pump type. The output signal of the VCO is routed via the phase detector at U808, pin 18 (FINIF).

The output of the phase detector is present at U808, pin 20 (DOIF) and than via the loop filter R829, C895, C860.

## Display and Keypad Description

### Display

The LCD (Liquid Crystal Display) Module is a Graphic Display based upon the KS0741TB-01 display driver.

It consist of LCD Holographic Glass, LED backlight and a 22 pin flex cable connected to the Keypad board.

The Communication to the RedCap2 IC is performed using a SPI protocol (Serial Peripheral Interface). The Operation of the LCD is determined upon the RS line configuration (Data/Command).

The Display is 128X100 (Columns X Rows respectively).

### Keypad

The RCE is responsible for decoding key presses and displaying them properly on the LCD. The keys are arranged into a matrix of five rows and five columns, which includes the Volume and PTT keys.

The PWR key is not decoded by the RCE; it directly drives the GCAP III, which sends a signal to RCE through INT1. The five row lines are pulled high via five internal 22 Kohm resistors. The five row lines and five column lines are fed to REDCAP2 I/O pins. Pressing any key also generates the keypad internal interrupt. The REDCAP2 debounces the keys by reading them 25 milliseconds later.

The keypad-decoding scheme works as follows:

1. REDCAP2 sets rows to inputs; all columns are set as outputs and driven logic low.
2. Rows are pulled logic high. When a key is pressed, one row goes low, which indicates a key press and sends an internal interrupt.
3. REDCAP2 reads rows. A low on that row indicates a key press. All others are high.
4. REDCAP2 sets all columns to output logic high.
5. One column at a time is set to output logic low. REDCAP2 reads the rows to see which one is now at a logic low level. (A low seen on a row indicates the correct column and row.)

All keypad circuitry is located on the keypad board. Refer to the keypad board schematics.

## Backlight and LEDs

### Backlight

The keypad backlight consists of 10 green LEDs. There are two more LEDs in the LCD module that are connected in parallel to the keypad LEDs.

### Top LEDs

There are one Green and one Red LEDs, both located on the LCD board. These LEDs are used as indicators to the radio operation.

## Radio Programming

The radio is entered into programming mode by setting the MOD pin high level, and applying a preamble sequence to the radio via the RS232 lines.

The MOD pin assertion is encountered at least 4 CKIH cycles before the negation of the Reset pin.

## Accessory Connector

The CE bus is intended to support connection to accessories, personal computers, and test systems. The bus connector has a total of 17 pins, 9 of which have multiple functions. The bus has six basic modes of operation: Normal (also No Accessory Connected), USB Mode, Analog Audio Mode, Phone Powered USB Mode, RS-232 Mode, and RS-232/SSI Mode (there is also two additional non-standard modes, DSC and FLASH which are used only for development, factory programming, and debugging). Eight of the 17 pins have different functions depending on which mode is selected. The other 9 pins always have the same function regardless of mode.

The mode is selected by applying appropriate logic levels to the Option Select pins, named OPTION1 and OPTION2. Some of the modes listed above are selected by the additional application of a level on the USB POWER and AUDIO-IN pins as well.

### Mode Select (OPTION1 and OPTION2)

Logic levels applied to the OPTION1, OPTION2, USB POWER, and AUDIO IN lines are used to select the CE Bus mode. The modes will be set as follows:

MODE	OPTION_1	OPTION_2	USB_PWR	AUDIO_IN
NORMAL (no accessory)	1	1	0	X
USB Accessory/Computer	1	1	>4.0V	X
Dumb Accessory	1	0	X	1
Phone Powered USB Accessory	1	0	X	0
RS-232 (8 wire)/IDB Smart Cable	0	1	X	1
RS-232 (4 wire)/SSI	0	1	X	0
PTT	0	0	X	X
SB9600	←		X	X

Pin No.	Signal Name (Short Form)	Power/Default States	USB	Dumb	RS232/SSI	RS232 (8 wire)
1	Power Ground (GND)	GND	GND	GND	GND	GND
2	Battery Feedback (BATT_FDBK)	BATT_FDBK	BATT_FDBK	BATT_FDBK	BATT_FDBK	BATT_FDBK
3	External Power (EXTB+)	EXTB+	EXTB+	EXTB+	EXTB+	EXTB+
4	USB+/TXD (D+)		D+	TXD	TXD	TXD
5	USB-/RXD (D-)		D-	RXD	RXD	RXD
6	USB Power/Ignition/RTS (USB_PWR)		USB_PWR	IGN	RTS	RTS
7	Switched Battery (SWB+)	SWB+	SWB+	SWB+	SWB+	SWB+
8	Hook Switch/CTS (HKS)		HKS	HKS	CTS	CTS
9	MUTE/FS/DCD (MUTE)			MUTE	FS	DCD
10	DUMB_SEL2/SCK/RI (DSEL2)	DSCEN	DSCEN	DSEL2	SCK	RI
11	DUMB_SEL1/SRDA/DTR (DSEL1)			DSEL1	SRDA	DTR



Pin No.	Signal Name (Short Form)	Power/ Default States	USB	Dumb	RS232/ SSI	RS232 (8 wire)
12	DUMB_SEL0/STDA/DSR (DSEL0)			DSEL0	STDA	DSR
13	Option 1 (OPT1)	UPLink	UPLink	OPT1	OPT1	OPT1
14	Option 2 (OPT2)	DNLink	DNLink	OPT2	OPT2	OPT2
15	Audio Out On/Off (AUDIO_OUT)	AUDIO_OUT	AUDIO_OUT	AUDIO_OUT	AUDIO_OUT	AUDIO_OUT
16	Audio In (AUDIO_IN)	AUDIO_IN	AUDIO_IN	AUDIO_IN	AUDIO_IN	AUDIO_IN
17	Audio Ground (AUDIO_GND)	AUDIO_GND	AUDIO_GND	AUDIO_GND	AUDIO_GND	AUDIO_GND

**THIS PAGE INTENTIONALLY LEFT BLANK**

---

---

## General

Troubleshooting faults in the radio require proper understanding of the different circuitry contained in the radio. Since the radio contains a highly integrated system, the software and hardware functions can not be separated easily. Thus, it is also necessary to understand the functioning of different ICs and the role of the software in the operation of the radio.

This service manual includes schematic diagrams, circuit board layouts, block diagrams, and troubleshooting procedures, which help a technician to troubleshoot a malfunctioning circuit and detect a defective component.

**NOTE:** The CPS has no capability to tune the radio. Tuning the radio can only be performed at the factory or at the appropriate Motorola Repair Centre. Components replacement can affect the radio tuning and must only be performed by the appropriate Motorola Repair Centre.

The radio is tuned and tested at the factory. The results of the tuning procedures are stored in a special EEPROM. This information includes tuning and other system parameters. The area of the memory in the radio where the tuning information stored is called the “codeplug”. A radio codeplug can be read using the CPS programme.

---

## Test Procedures

This section explains the procedures required to troubleshoot a MTH500 radio.

The digital tests should be performed using the GoNoGo PATS test and TetraCom SW. To use the TetraCom you must go to test mode by using the command <Test Enter>.

## Troubleshooting Flowcharts

Use the following flowcharts to troubleshoot the radio. These flowcharts contain procedures using TetraCom SW application, GoNoGo PATS test and factory test modes for troubleshooting radios having digital, receiver, transmitter, or frequency generation test failures.

### DMO Troubleshooting Charts

The troubleshooting flowcharts for the DMO mode are same like the TMO mode. If a problem occurs in the DMO mode, then refer to the respective flowchart given under TMO mode. When a problem is found and fixed according to the TMO troubleshooting charts, then it is automatically fixed in the DMO. However, if the problem still remains in the DMO mode and not in the TMO mode, then the software should be fixed.

### TMO Troubleshooting Charts

The following flowcharts are included for the TMO mode:

- \* Digital Troubleshooting
- \* Transmitter Troubleshooting
- \* Receiver Troubleshooting
- \* Synthesizer Troubleshooting
- \* Audio Troubleshooting

## Digital Troubleshooting

### Digital Analysis Test

Use this test for troubleshooting the main board.

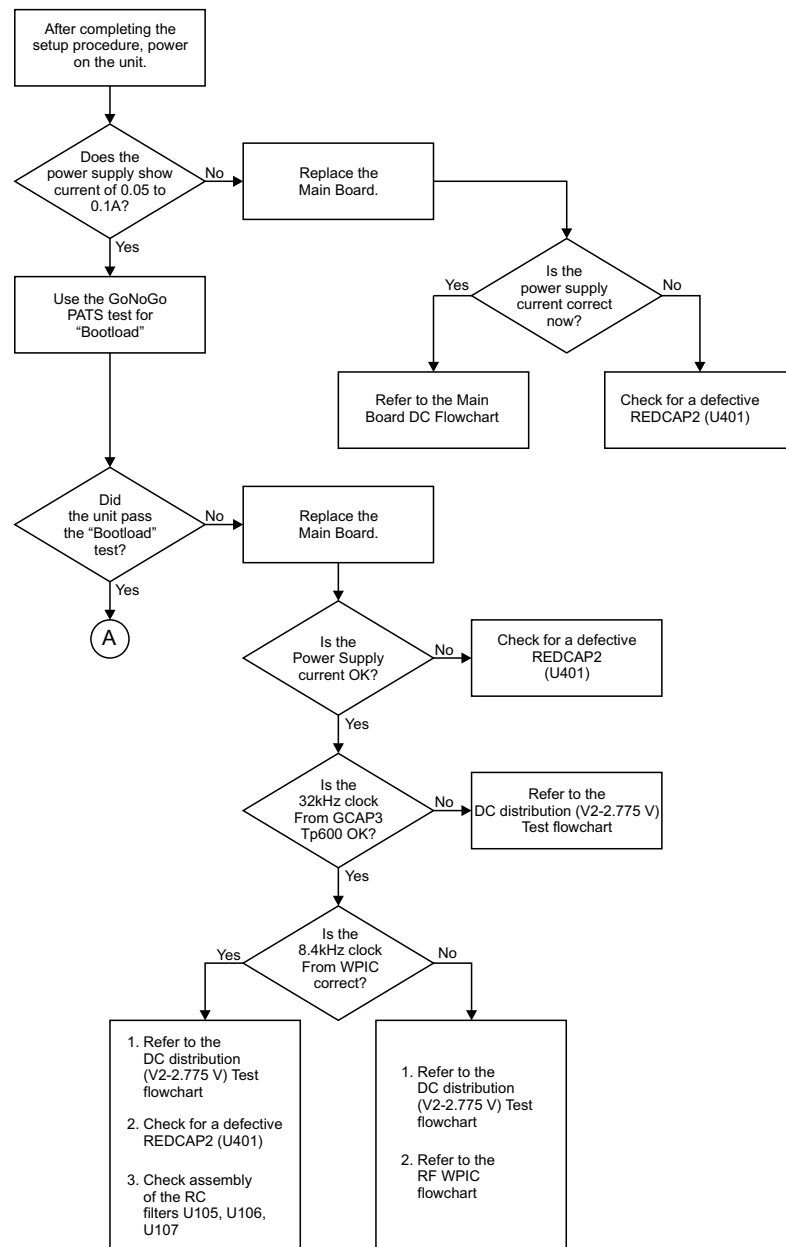

### Digital Analysis Test (Cont.)

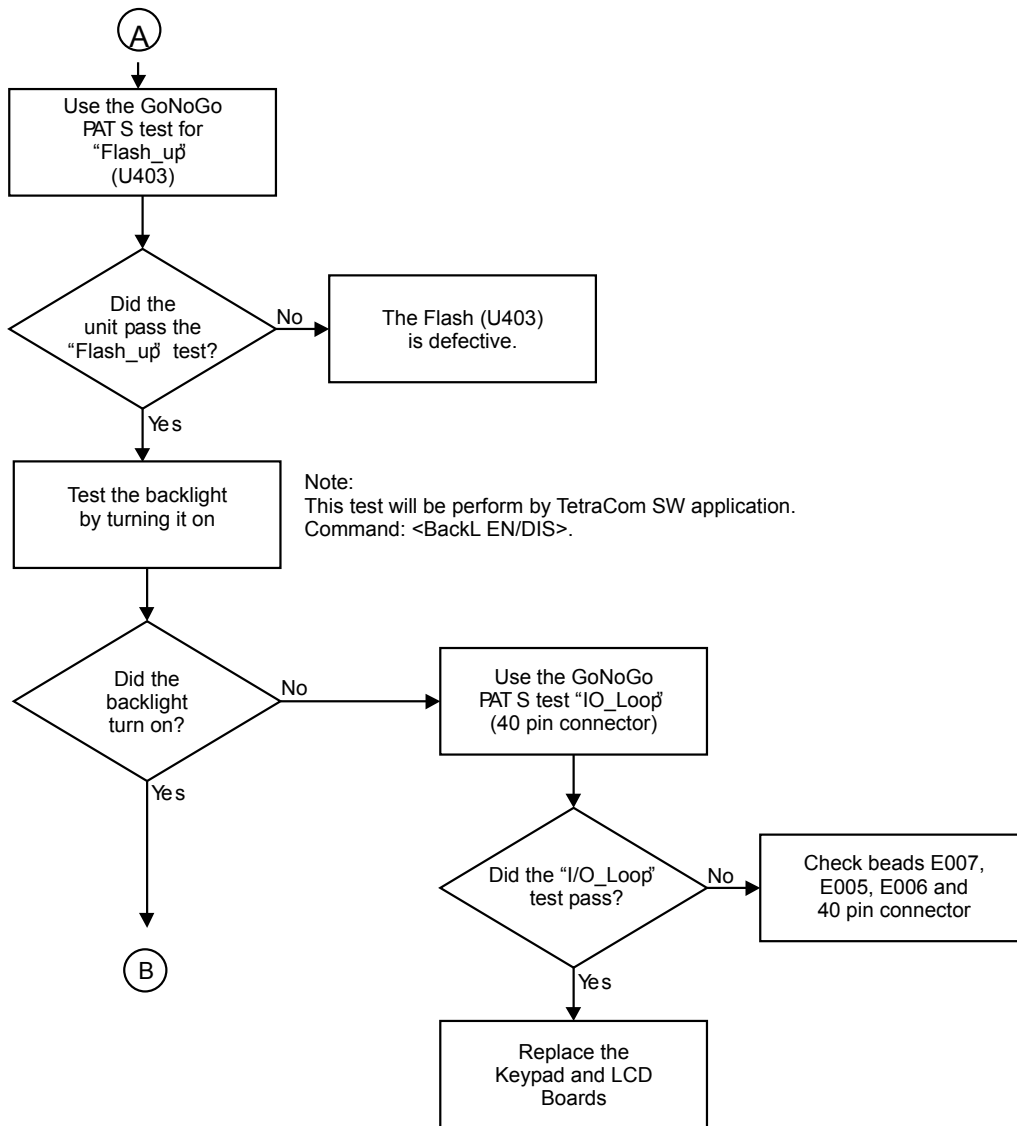

Digital Analysis Test (Cont.)

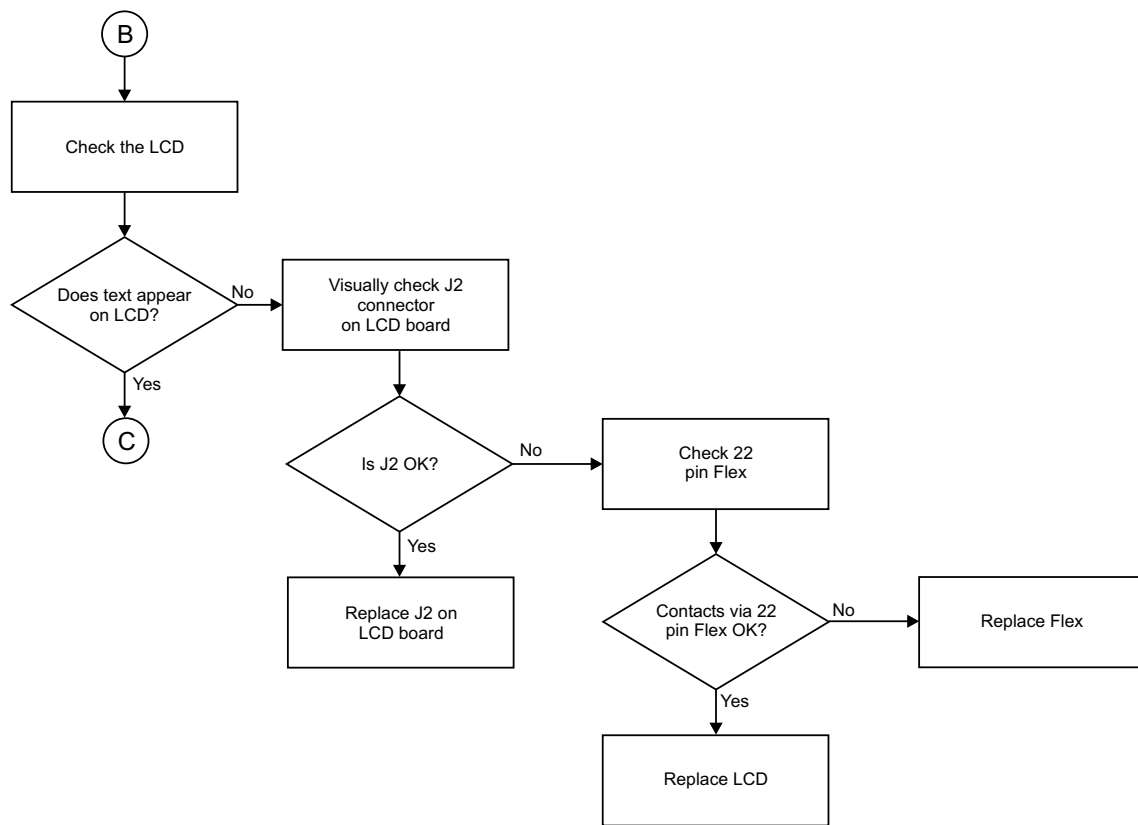

### Digital Analysis Test (Cont.)

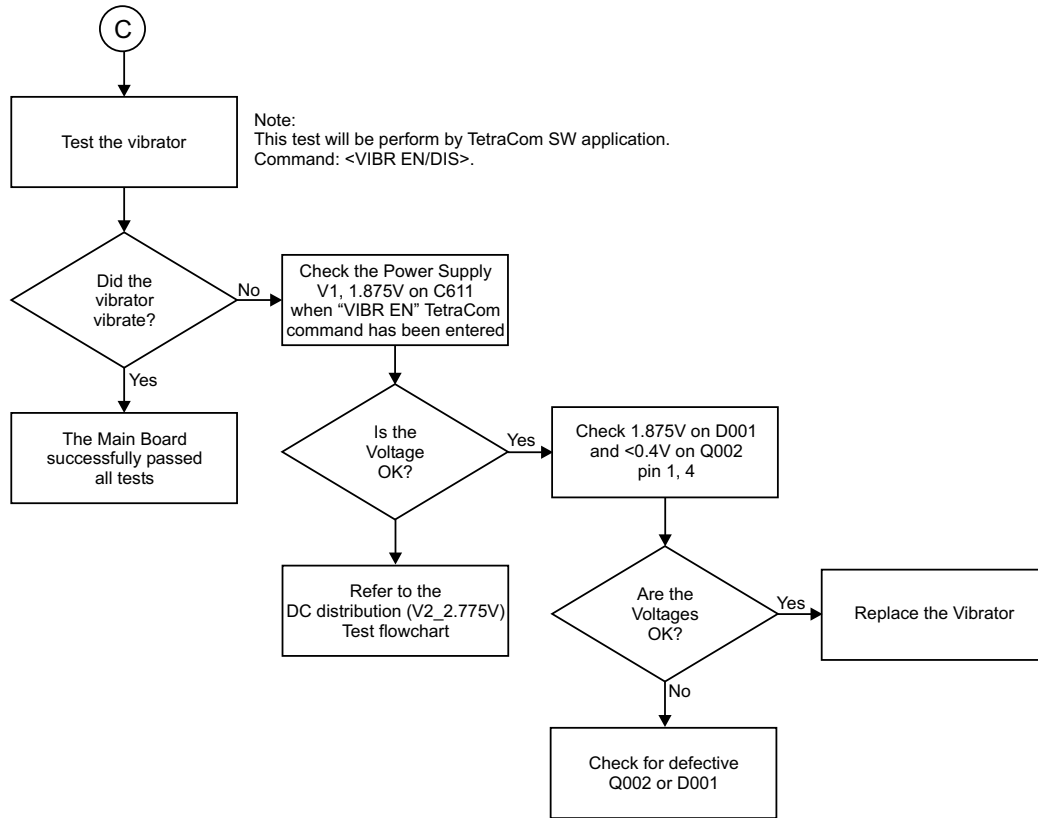



---

### DC Distribution (V2\_2.775V) Test

Use this test on a unit with the following symptoms: no power, no V2\_2.775V, V1\_1.875V, V3\_2.775V, VREF1\_2.775V, VREF2\_2.775V.

**Note:** The following are the DC power distribution voltages with their correct values and appropriate location to check the voltages:

- Fused\_B+ (3.6 Vdc) @ F600
- Filt\_B+ (3.6 Vdc) @ C640
- V1\_1.875V (1.875 Vdc) @ C611
- V2\_2.775V (2.775 Vdc) @ C610, C613, C657
- V3\_2.775V (2.775 Vdc) @ C609, C658, C659
- VREF1\_2.775V (2.775 Vdc) @ C628
- VREF2\_2.775V (2.775 Vdc) @ C612, C660, C661
- V4\_2.775V (2.775 Vdc) @ C625, C644, C647
- VSIM1 (3 Vdc) @ C653
- 5V\_RF (5 Vdc) @ C615, C651
- PWM2\_1.8V (1.8 Vdc) @ C624, C648
- PWM1\_5.6V (5.6 Vdc) @ C623

DC Distribution (V2\_2.775V) Test (Cont.)

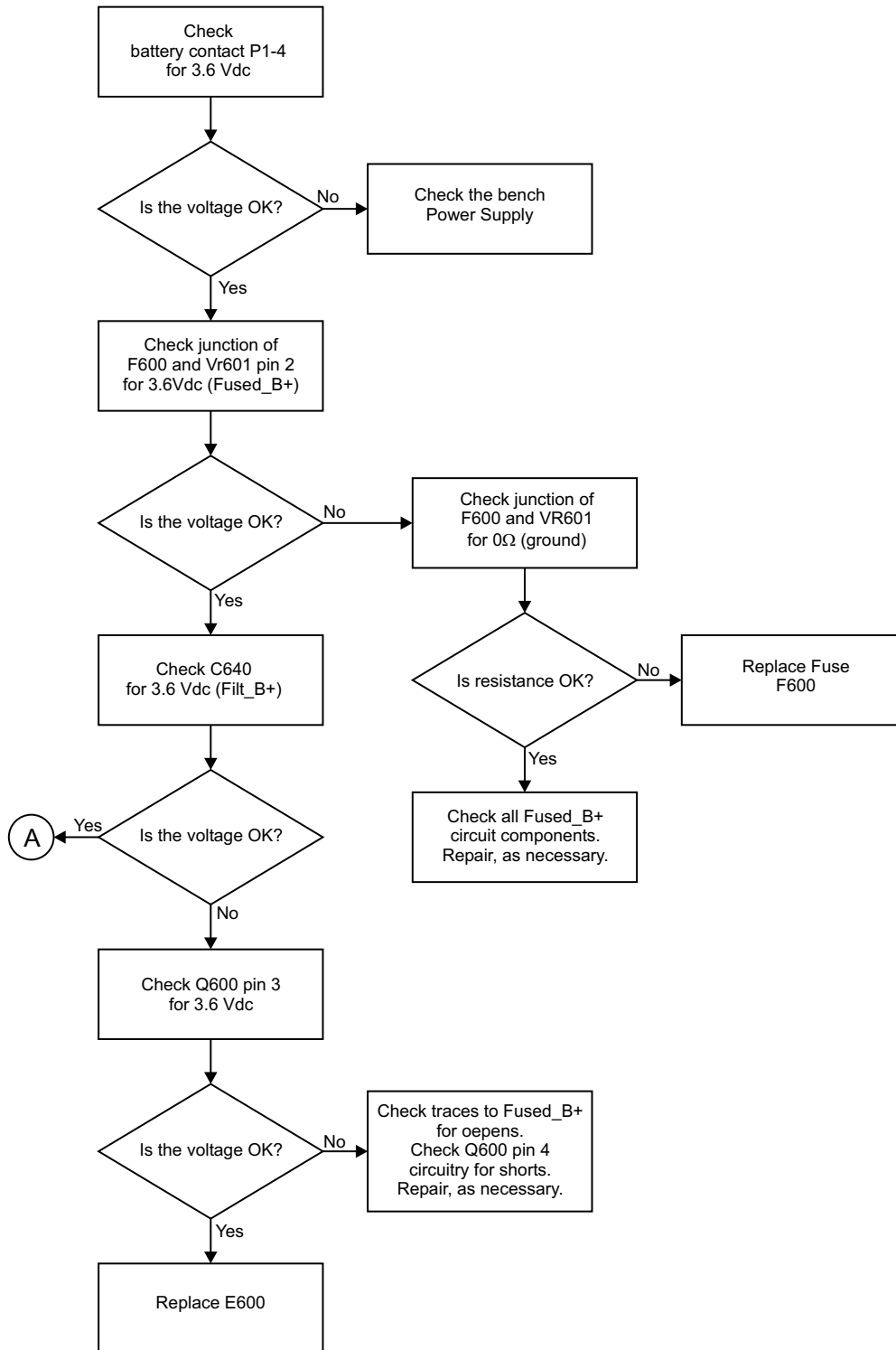

**DC Distribution (V2\_2.775V) Test (Cont.)**

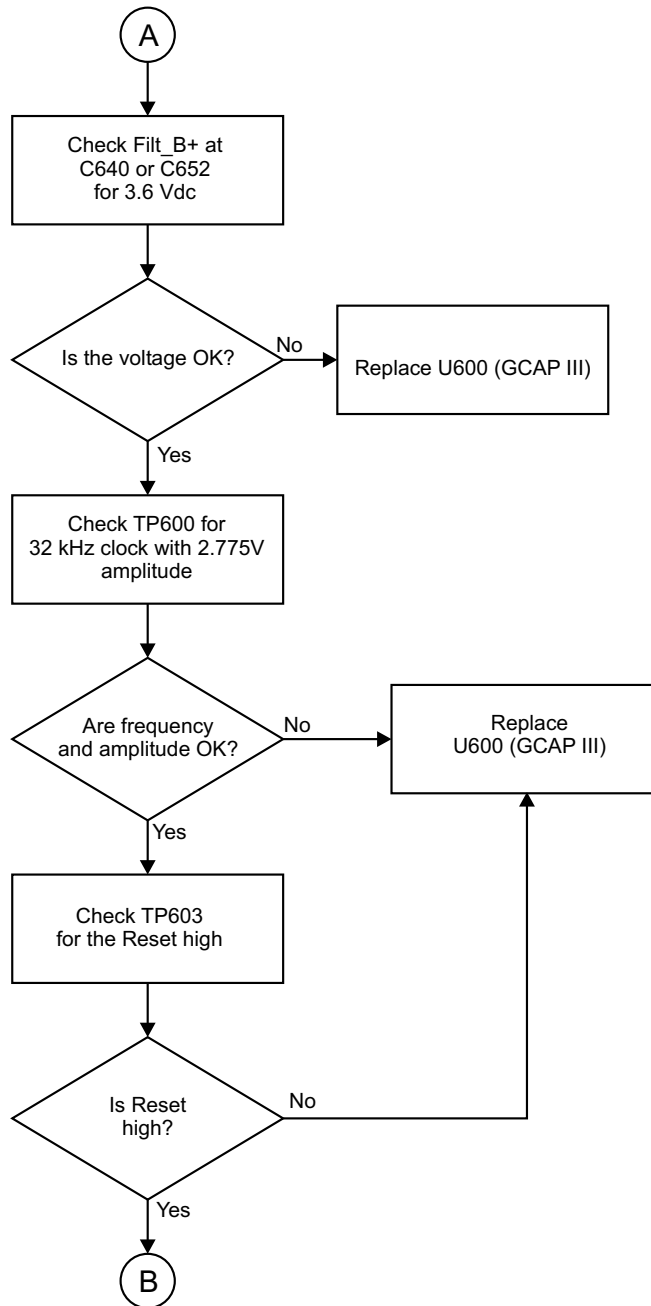

**DC Distribution (V2\_2.775V) Test (Cont.)**

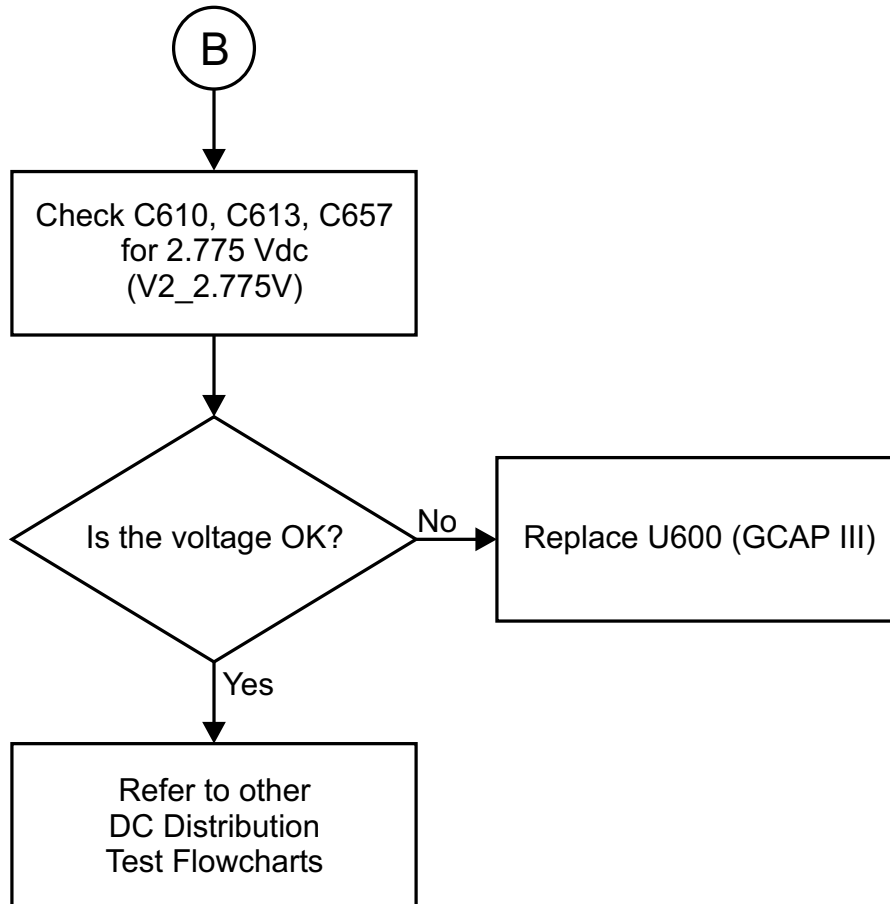

### DC Distribution (SWB+) Test

Use this test on a unit with the following symptoms: no SWB+.

Note: This test will be performed using TetraCom SW application commands <SWB EN/Dis>.

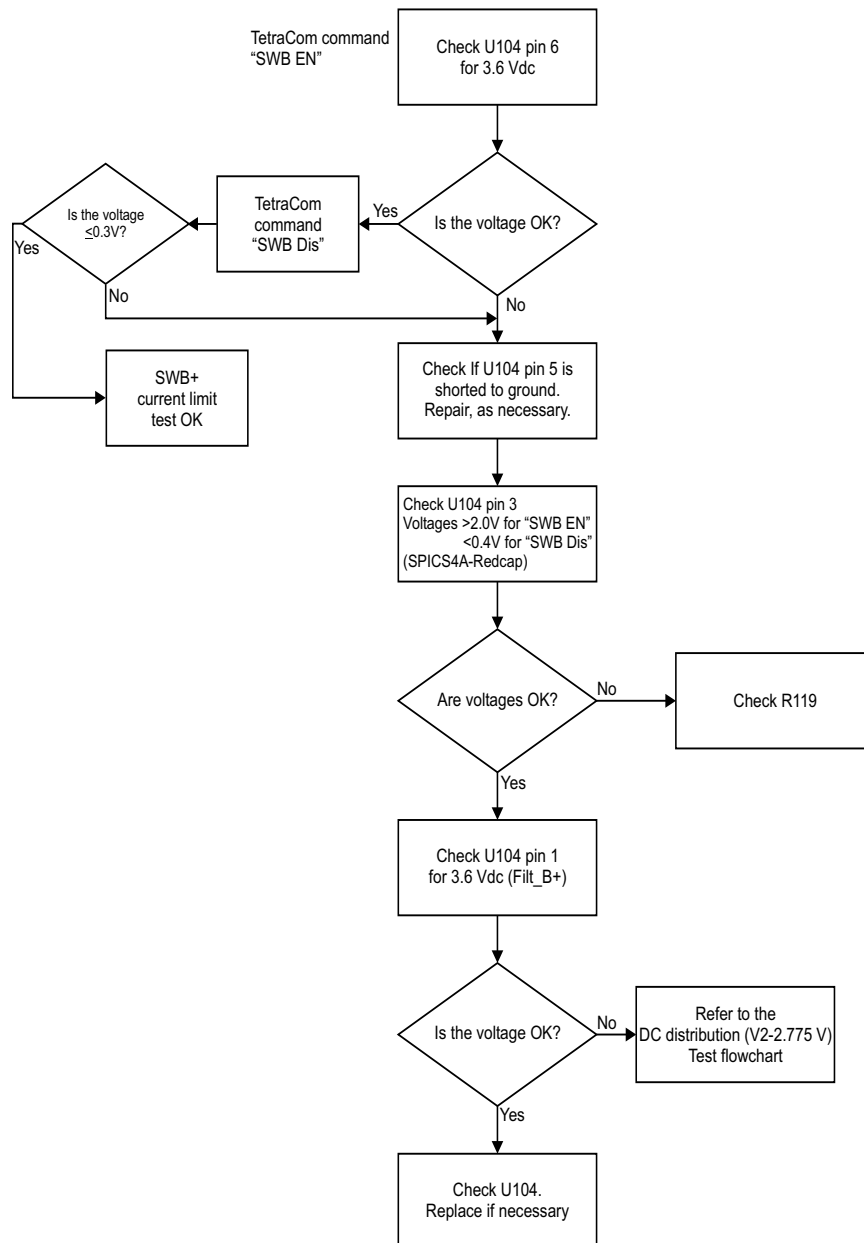

### DC Distribution (V4\_2.775V) Test

Use this test on a unit with the following symptoms: no V4\_2.775V.

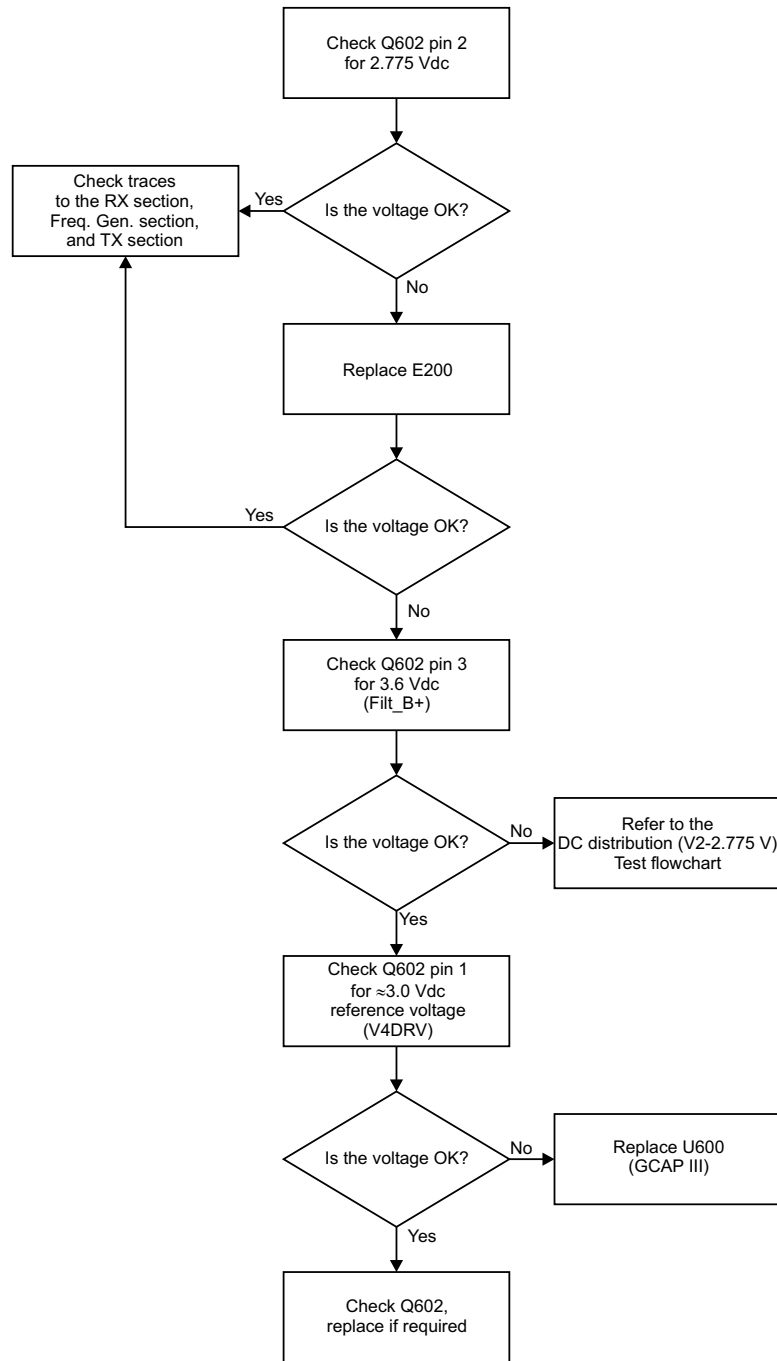

### DC Distribution (V3\_2.775V/PWM2\_1.8V) Test

Use this test on a unit with the following symptoms: no V3\_2.775V, no PWM2\_1.8V.

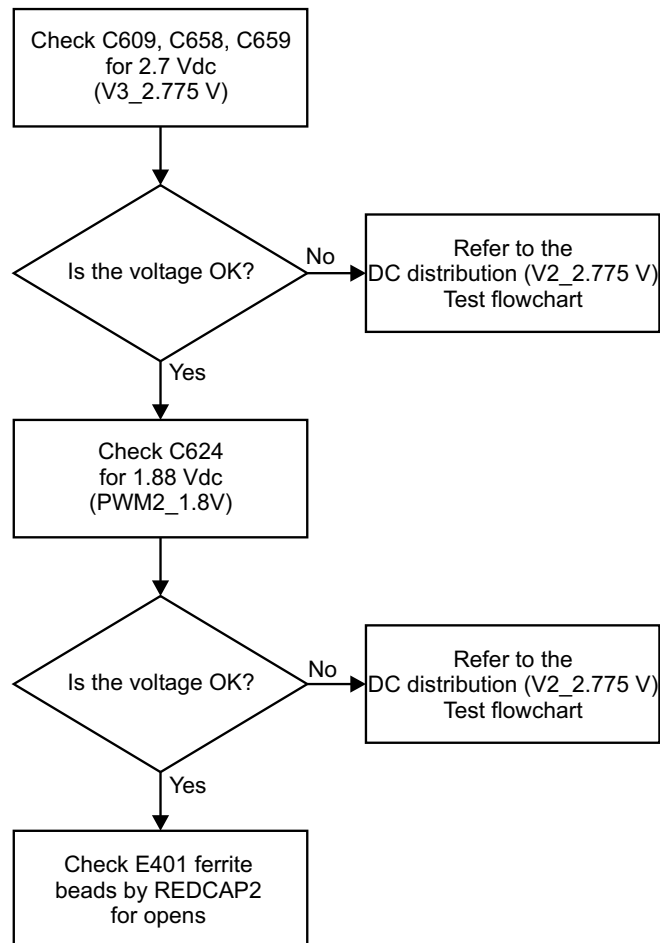

### DC Distribution (V5\_RF/PWM1/VSIM1\_5.6V) Test and (VSIM1) Test

Use these tests on a unit with the following symptoms: no V5\_RF, no PWM1\_5.6V, or no VSIM1\_5.6V.

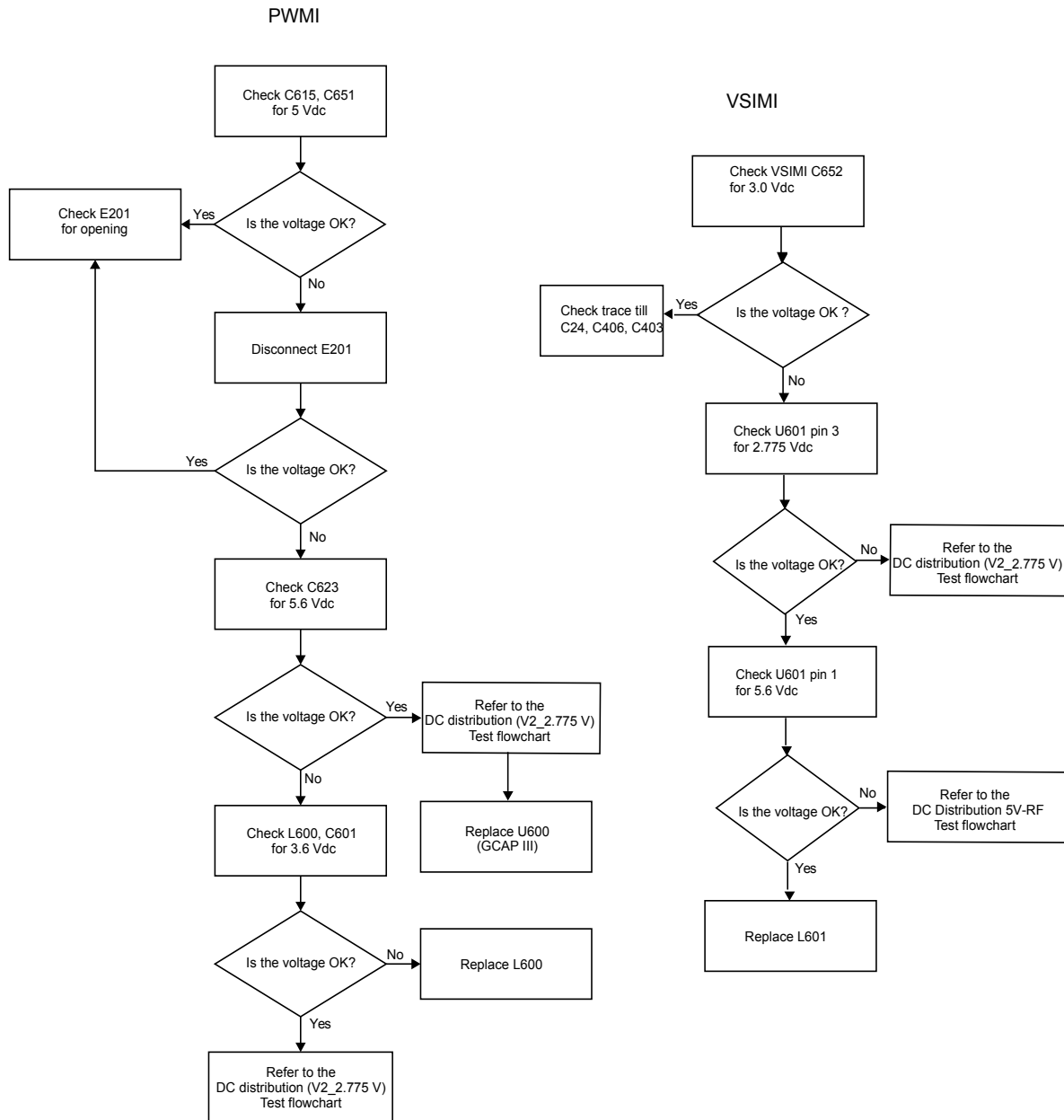



## Transmitter Troubleshooting

### Standby Current Troubleshooting

This test should be carried out only after the successful completion of the previous tests.

Note: The standby upper current limit is 100mA and lower limit is 4mA

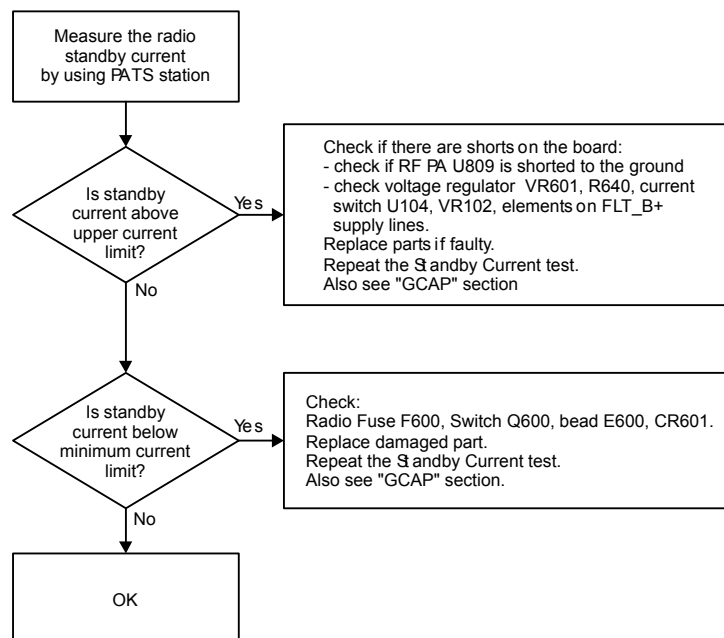

## Open Loop Power Test

This test should be carried out only after the successful completion of the previous tests.

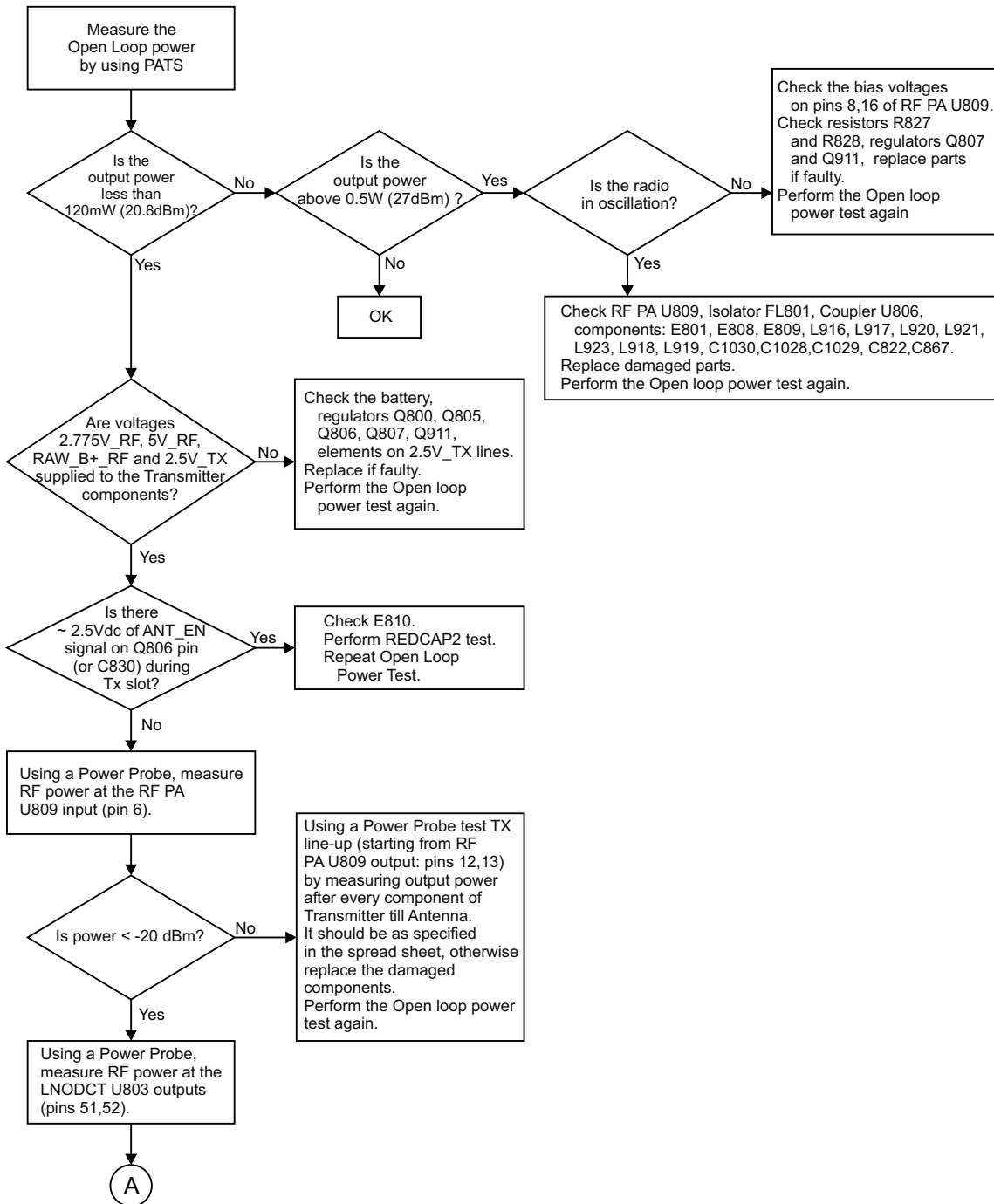

### Open Loop Power Test (Cont.)

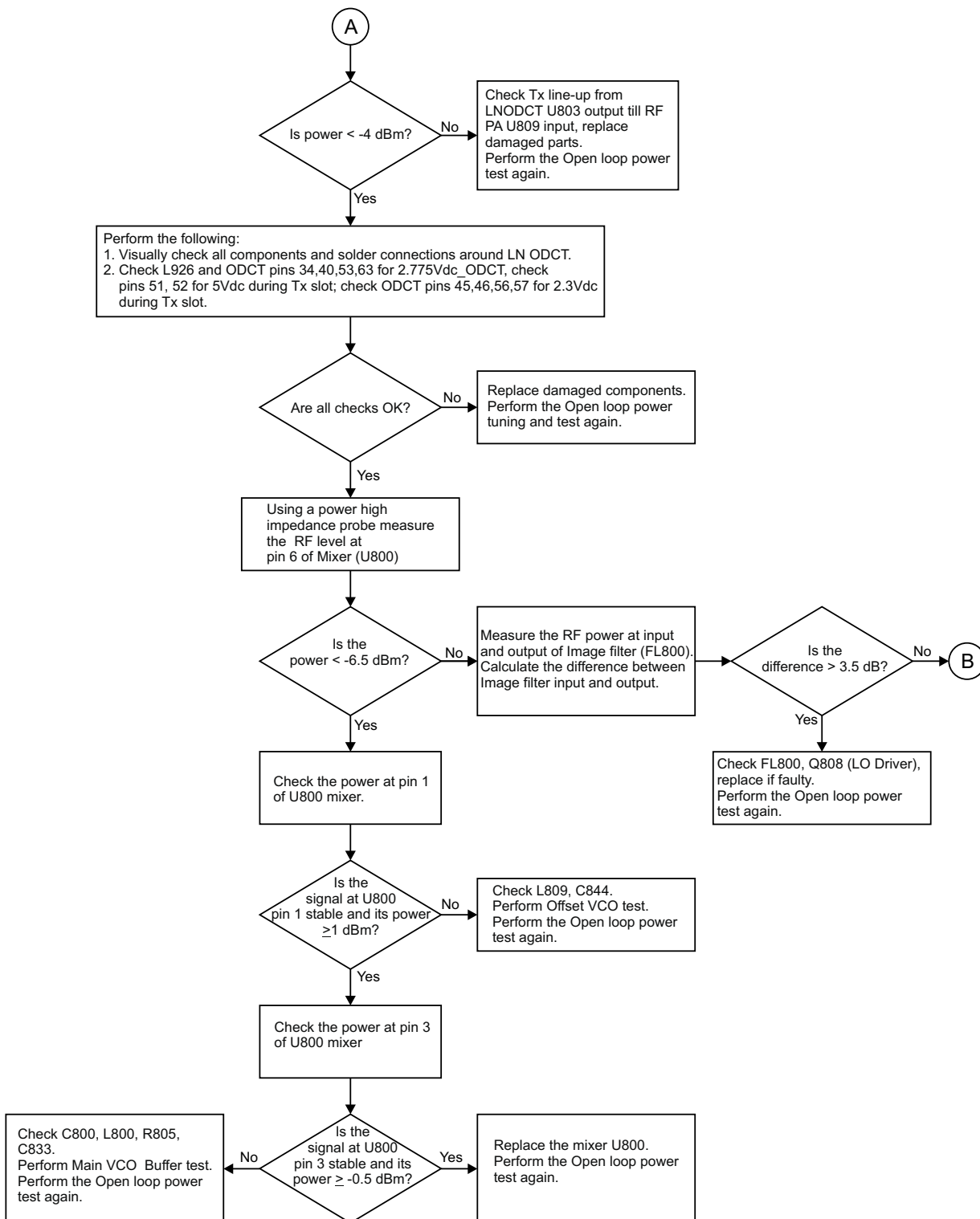

### Open Loop Power Test (Cont.)

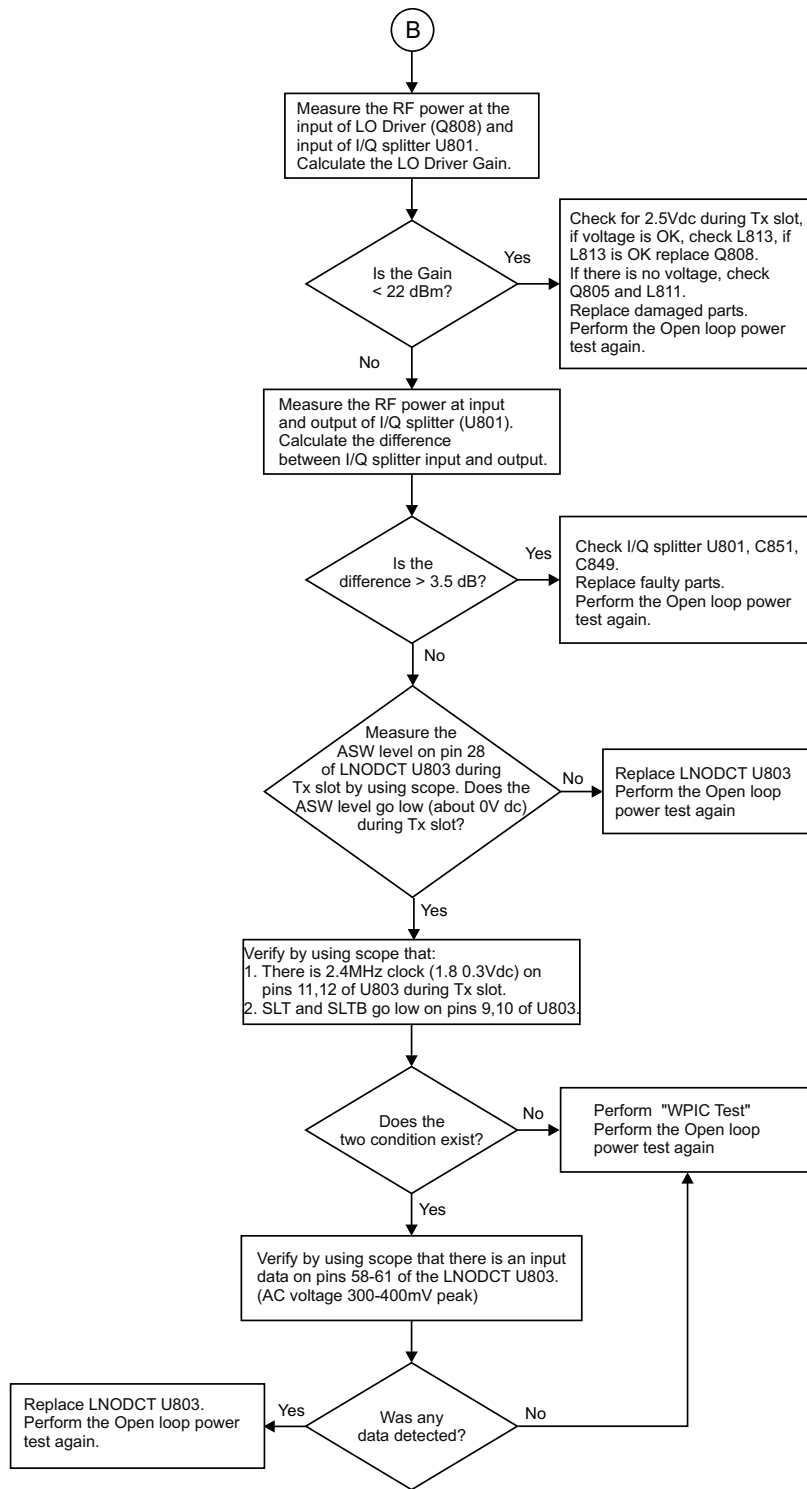

### WPIC Test

This test should be started in accordance to Open Loop Power test.

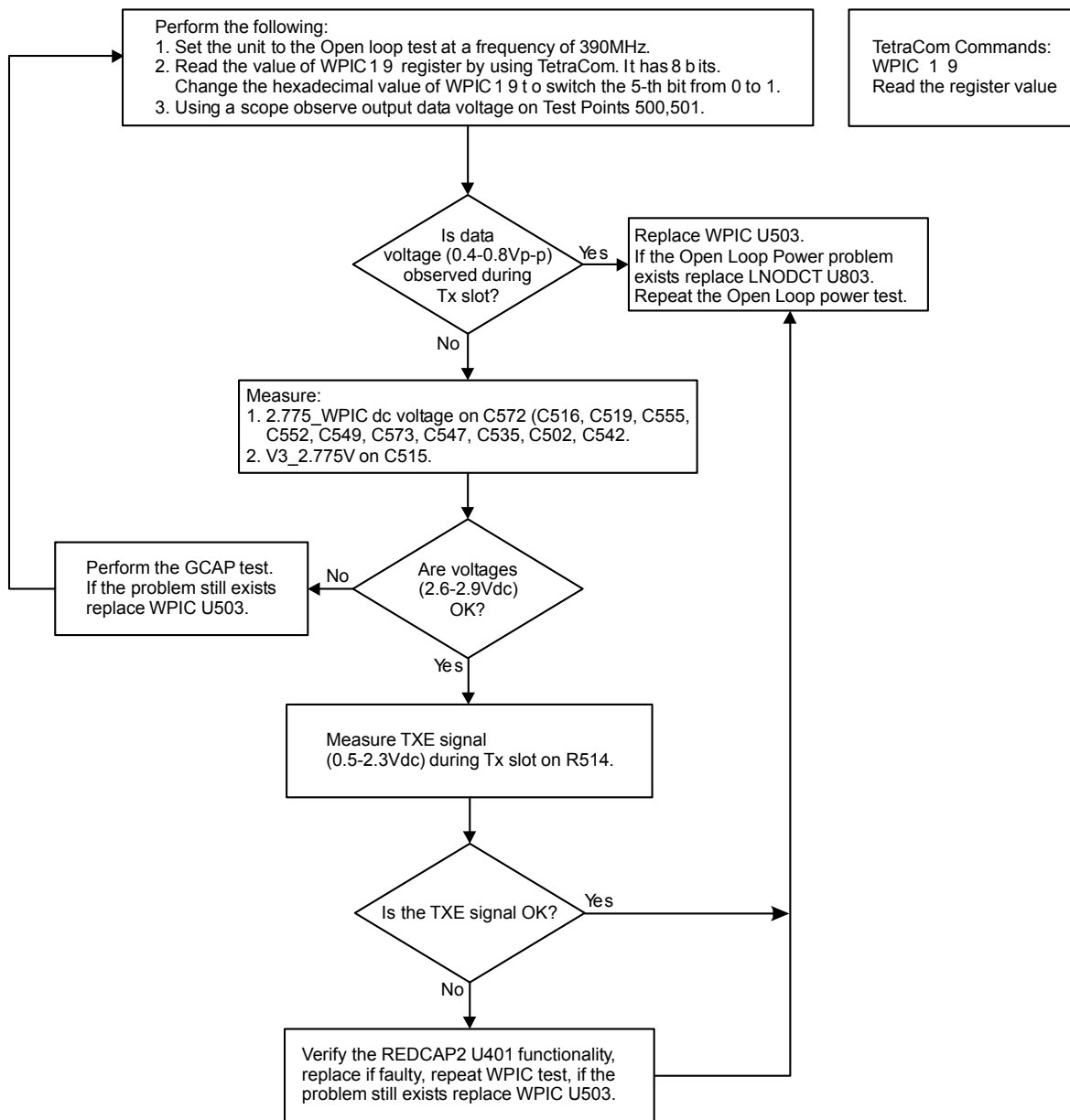

### Closed Loop Power Test

This test should be carried out only after the successful completion of the previous tests.

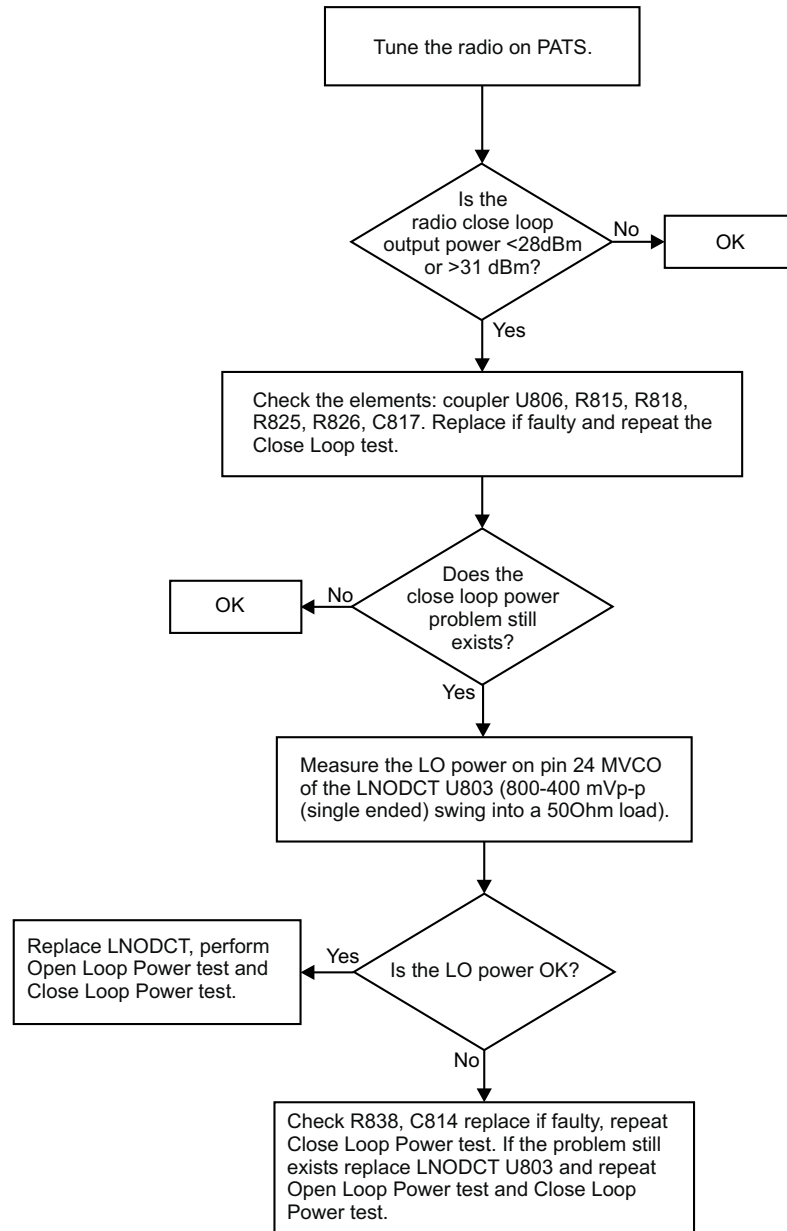

### Transmitter Current Consumption Test

This test should be carried out only after the successful completion of the previous tests.

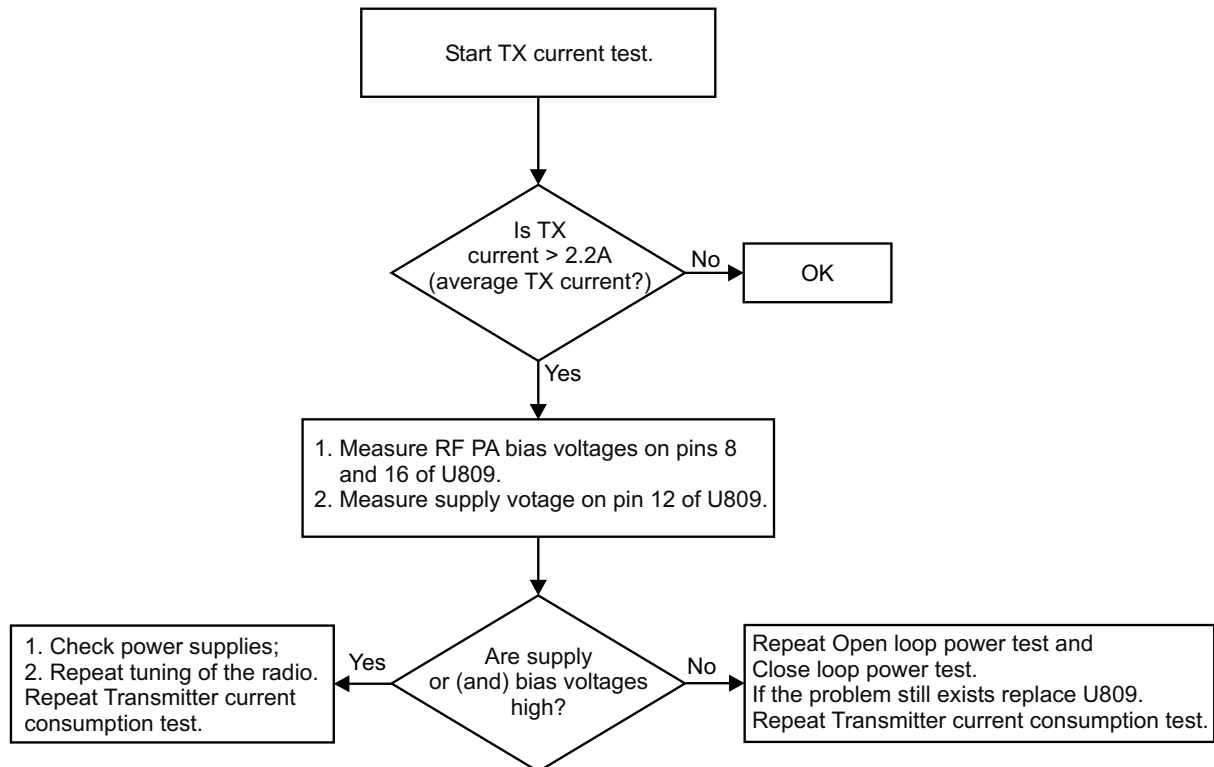

Receiver Troubleshooting

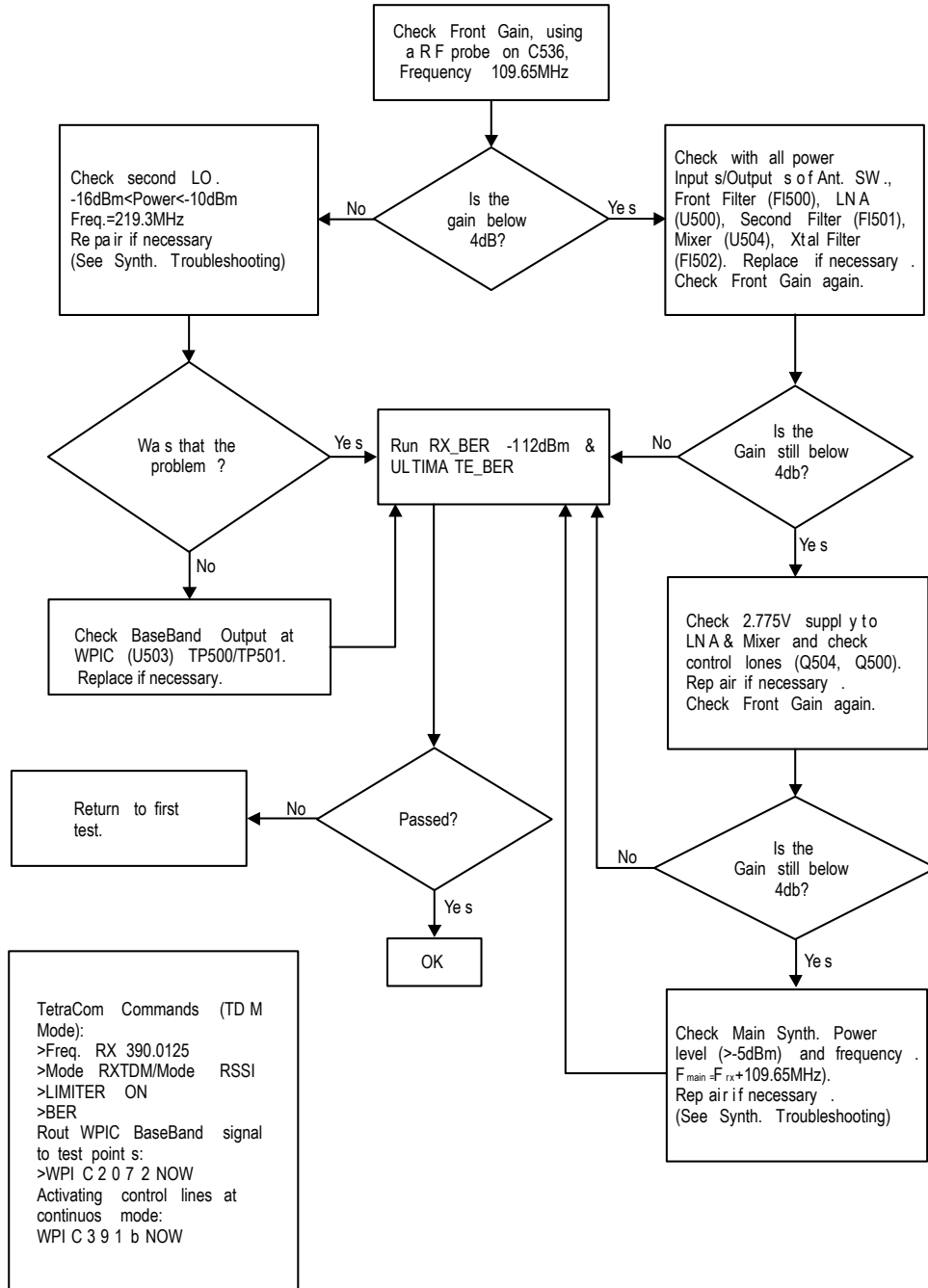



## Synthesizer Troubleshooting

Use this test on a unit with the following symptom: no Tx or Rx

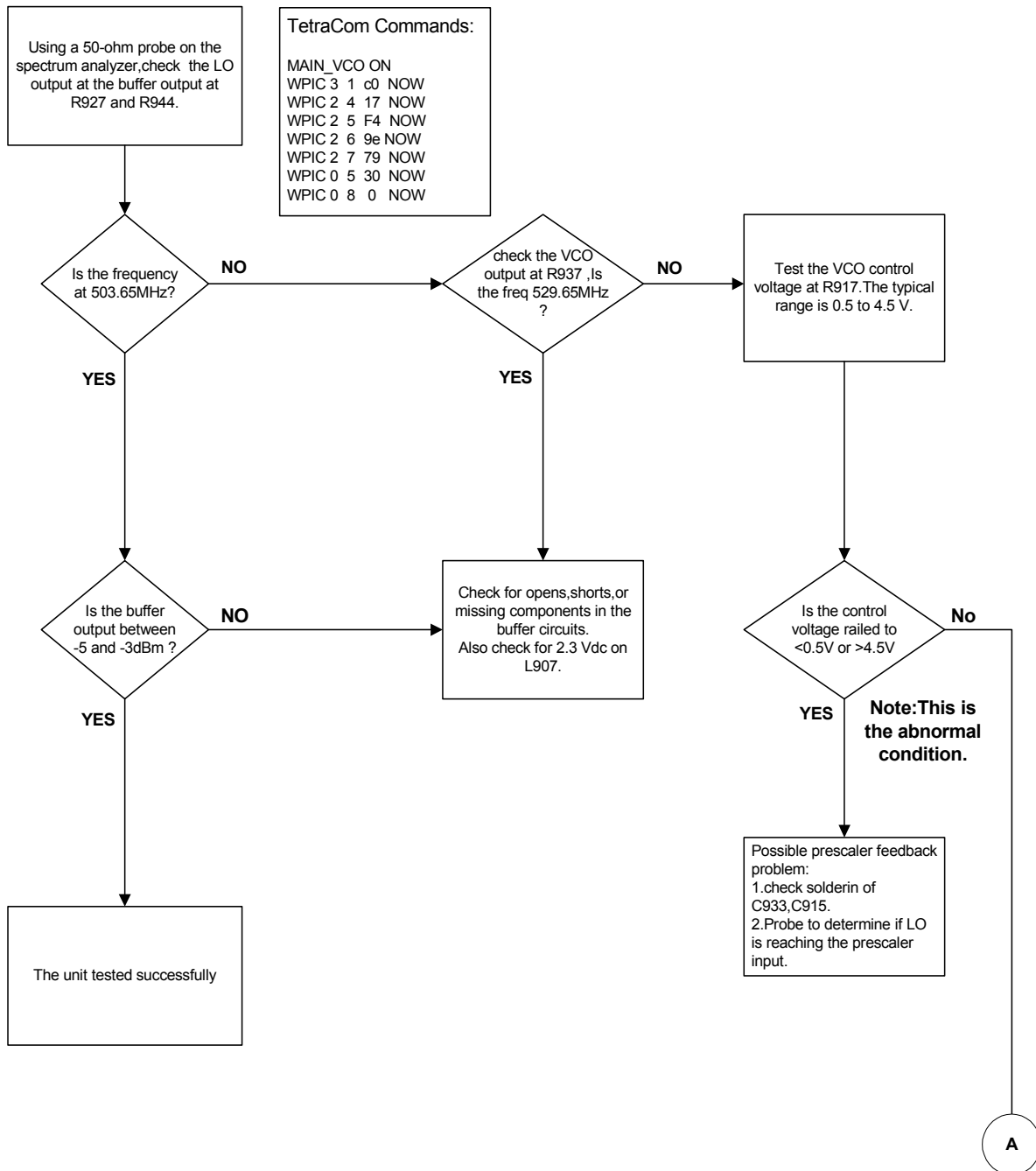

Synthesizer Troubleshooting (Cont.)

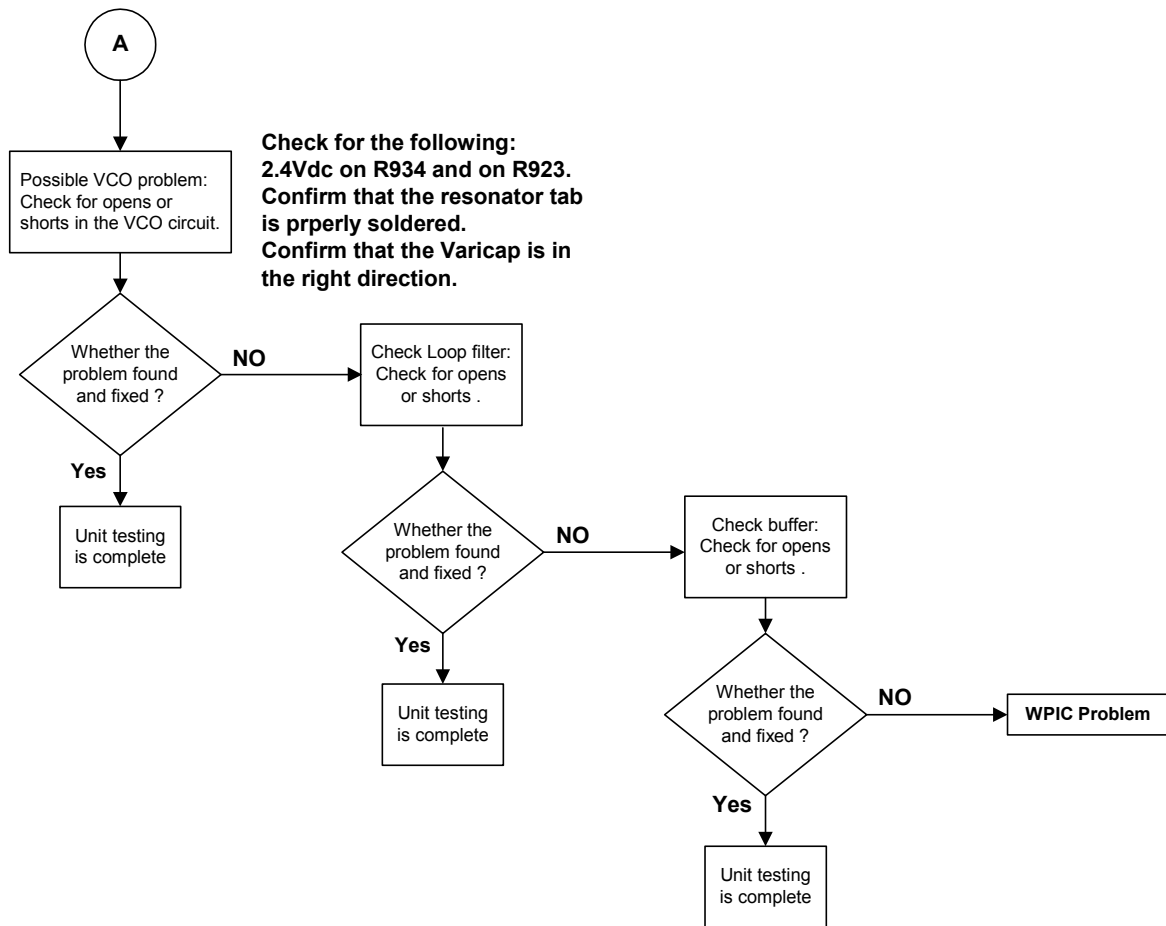

### Second LO VCO Test

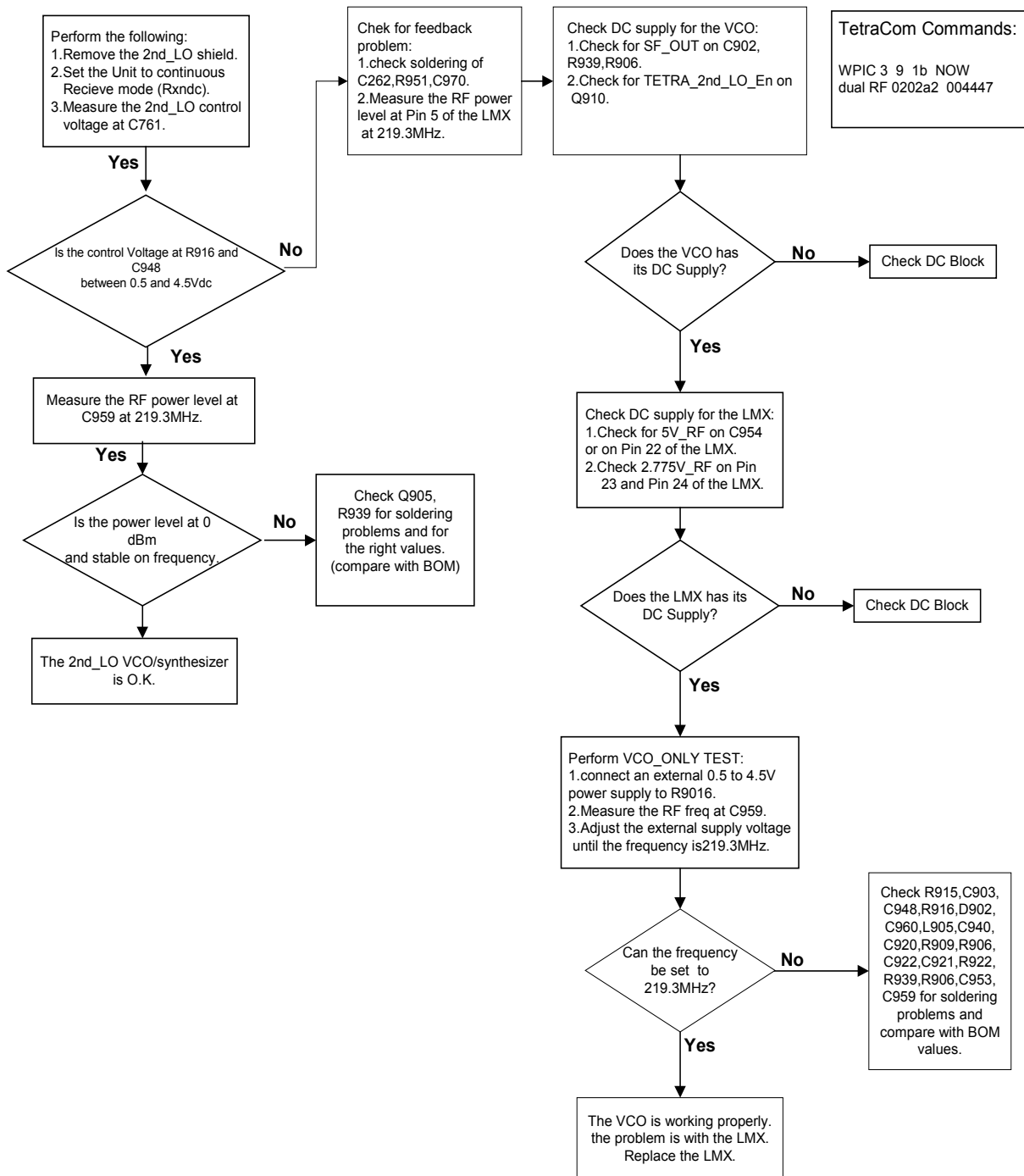

### Offset VCO Test

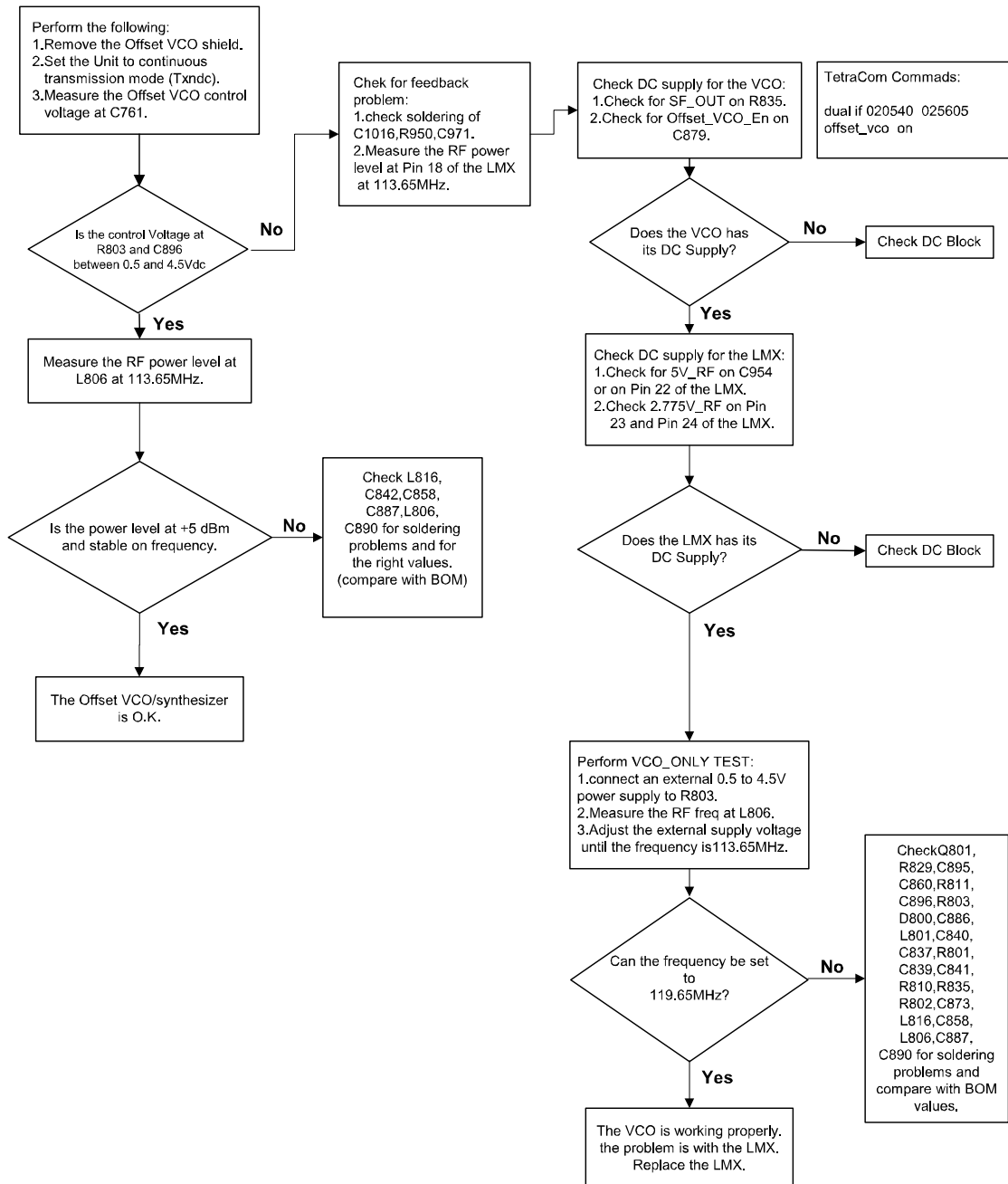

### Audio Troubleshooting (External Mic to External Out)

Set the audio input to the external mic to 1.02KHz @ 44mV RMS. Test sequence is controlled by TetraCom commands to the external mic-to-external out loopback.

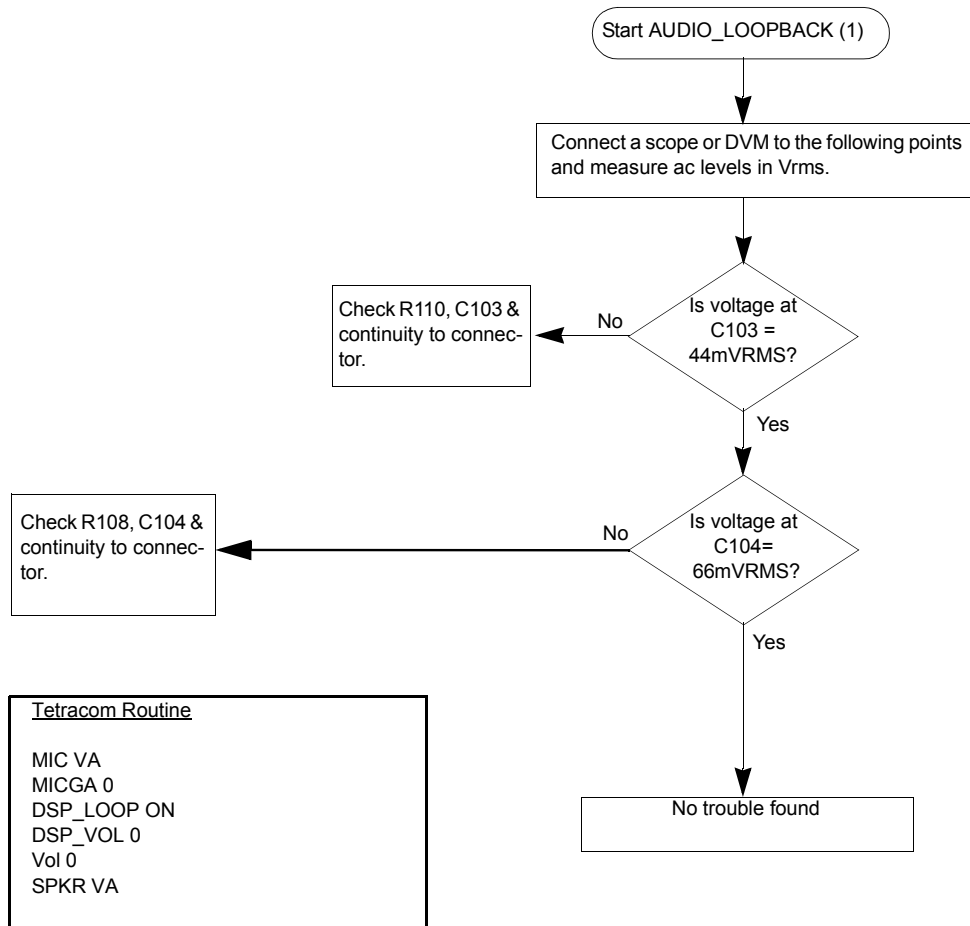

**This page left blank intentionally**



# Programming the Radio

---

---

## Programming The Radio

1. Verify that the radio is turned off.
2. Run the Customer Programming Software (CPS) on your computer.

## Codeplug Programming

1. On the menu bar, click "File" "Open".
2. Browse for the required Codeplug file and open the file.
3. The CodePlug window appears on the screen.
4. Click the Toolbar "Tools" icon and select "Write Entire Codeplug".
5. Press the "Yes" icon.

NOTE: The Codeplug is now being written into the radio. A progress bar is displayed on the computer screen showing the writing status. The following display is shown on the radio screen:

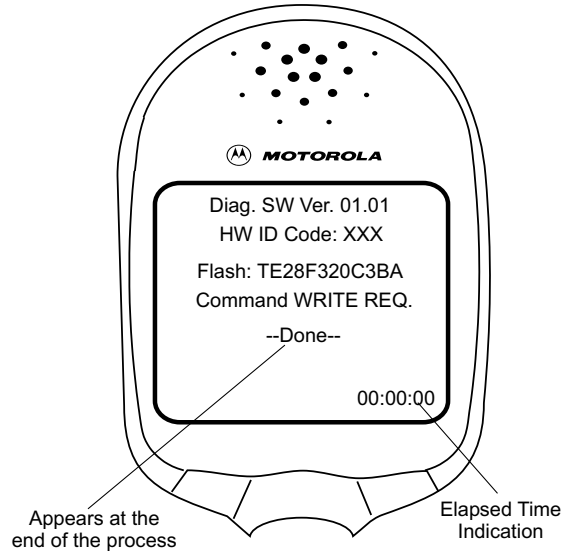

After a successful writing, the message “The Operation Was Successful” appear on the computer screen.

6. Press the OK button.

## Application Programming

1. On the menu bar click “Tools”, “Write Software”.

NOTE: The CPS is trying to reads data from the radio. A “Please Wait” message is displayed on the computer screen. After the process ends, a “Operation Results” window appears on the computer screen.

2. Press the “Write” button.



NOTE: The application is now being written into the radio. A progress bar is displayed on the computer screen showing the writing status. The following display is shown on the radio screen:

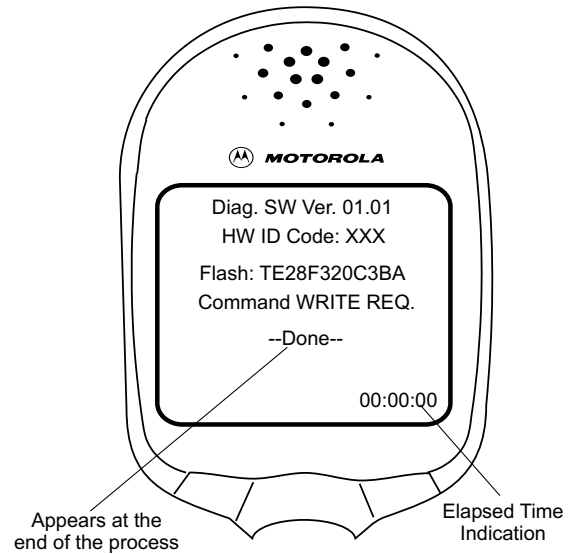

After a successful writing, the message “The Operation Was Successful” appear on the computer screen.

3. Press the “Ok” button.
4. Click the toolbar “R” (Reset) icon.

This page left blank intentionally



---

---

## Preventive Maintenance

This portable radio does not require a scheduled preventive maintenance program. However, periodic visual inspection is recommended.

## Inspection

Inspect the radio's external surfaces. A detailed inspection of interior circuitry is not needed or recommended.

## Cleaning

The following procedures describe the recommended cleaning agents and methods to be used when cleaning the external and internal surfaces of the radio. External surfaces should be cleaned whenever a periodic visual inspection reveals the presence of smudges, compound, or grime. Internal surfaces (circuit boards and components) should be cleaned only when the radio is disassembled for servicing or repair.

The only recommended agent for cleaning external radio surfaces is a 0.5% solution (one teaspoon of detergent per gallon or four litres of water) of mild dishwashing detergent in water. The internal surfaces should be cleaned only with isopropyl alcohol (70% by volume).

---

## Safe Handling of CMOS Devices

Complementary metal-oxide semiconductor (CMOS) devices are used in the radio. While the attributes of CMOS devices are many, their characteristics make them susceptible to damage by electrostatic or high voltage charges. Damage can be latent, resulting in failure occurring weeks or months later. Therefore, special precautions must be taken to prevent device damage during disassembly, troubleshooting, and repair. The following handling precautions are mandatory for CMOS circuits, and are especially important in low humidity conditions.

- All CMOS devices must be stored or transported in conductive material so that all exposed leads are shorted together. CMOS devices must not be inserted into conventional plastic “snow” or plastic trays of the type that are used for storage or transportation of other semiconductor devices.
- All CMOS devices must be placed on a grounded bench surface and the technician must also be grounded before handling the devices. This is done most effectively by having the technician wear a conductive wrist strap in series with a 100k $\Omega$  resistor to ground.
- Do not wear nylon clothing while handling CMOS circuits.
- Do not insert or remove CMOS devices with power applied. Check all power supplies to be used for testing CMOS devices and be certain there are no voltage transients present.
- When straightening CMOS device leads, provide ground straps for the apparatus used.
- When soldering, use a grounded soldering iron.
- All power must be turned off in a system before printed circuit boards containing CMOS devices are inserted, removed, or soldered.

---

## Disassembling and Reassembling the MTH500 Unit

Mechanical checks and self tests should be performed on the unit at the basic level of service. To perform testing at the field level, it is sometimes necessary to remove the antenna and the housing from the unit. Procedures for disassembling and reassembling the unit are described in the sections that follow.

NOTE: Read each procedure thoroughly before performing the actual task.

## Protecting Static-Sensitive Devices

This unit contains static-sensitive devices that must be protected when opening the unit, or storing and transporting any printed-circuit board.

### **To create a proper ground:**

- Ground the working surface of your service bench.

If possible, use the Motorola Static Protection Assembly (part #0180386A82) to ground your service bench. This assembly contains a wrist strap, two ground cords, a table mat, and a floor mat.

- Wear a conductive wrist strap in series with a 1Mg ohm resistor to ground.
- Do not wear nylon clothing when handling any printed-circuit board.
- Prior to touching any printed-circuit board, touch an electrical ground to remove any static charge that might have accumulated.

### **To store or transport a circuit board:**

- Place the printed-circuit board in conductive, anti-static material.
- Do not insert the printed-circuit board into conventional plastic “snow” trays used for transporting other devices.

## Removing and Installing the Antenna

The antenna must be removed each time the back housing is removed.

Recommended tools: no tools are required

### To remove the antenna from the unit:

(See Figure 13)

- Unscrew the antenna counter clockwise until it is detached from the handset.

### To install the antenna in the unit:

- Screw the antenna clockwise to the handset.

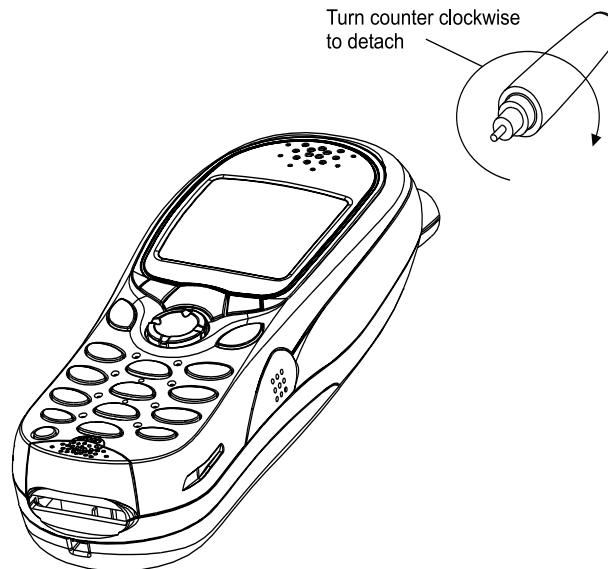

Figure 13 Antenna Removal and Installation

## Removing and Installing Battery Door and Battery

Recommended tools: no tools are required

### To remove the battery door from the unit:

(See Figure 14)

1. Place the unit facing down on the work area.

2. Press the battery door release button, slide the door towards the bottom of the unit and lift it up from the unit.

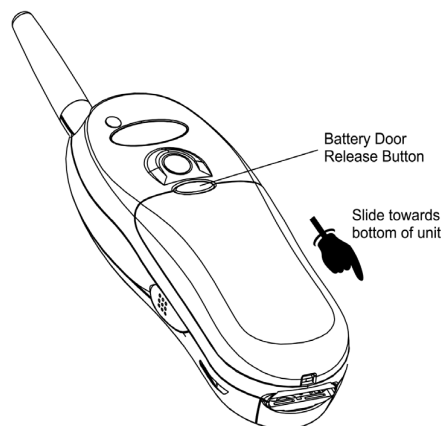

Figure 14 Battery Door Removal

**To remove the battery:**  
(See Figure 15)

1. Press the battery fastening bridge toward the upper side of the unit.
2. Simultaneously, using other hand, release the battery from its chamber.

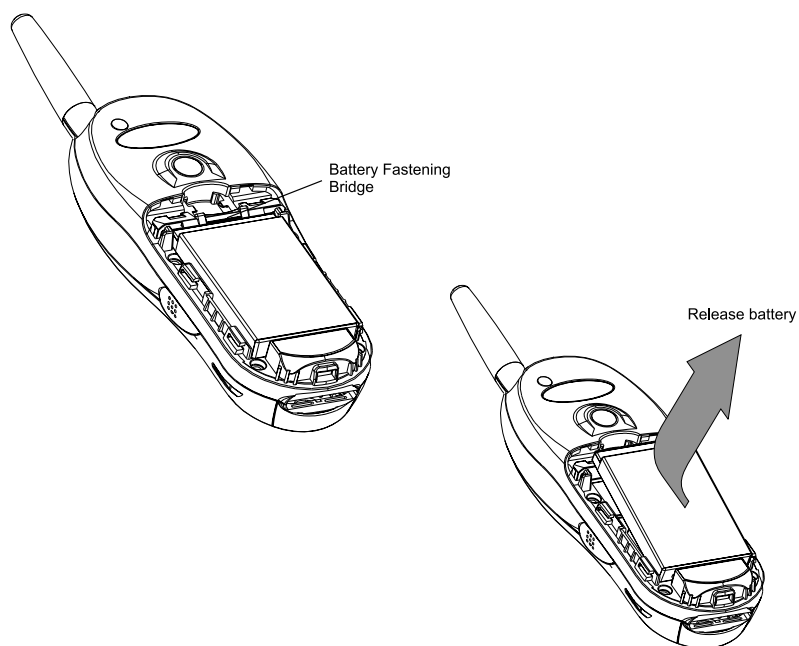

Figure 15 Battery Removal

**To install the battery:**

1. Locate the battery so that the lower part (coloured silver) is touching the lower wall of the battery chamber.
2. Carefully press the battery down until it snaps into location.

**To install the battery door:**

1. Position the door on the unit over the battery so that the door release button is just above the battery fastening bridge.
2. Slide the door upward until the door snaps into location.
3. Verify that the door is aligned with the handset back housing.

**Removing and Installing the Back Housing**

Recommended tools: T-8 Torx bit, Torx driver, mini flat-tip screwdriver

**Removing the back housing from the unit:**

(See Figure 16)

1. Remove the antenna, refer to “Removing and Installing the Antenna”.
2. Remove the battery door and the battery, refer to “Removing and Installing Battery Door and Battery”.
3. Place the unit facing down on the work area.
4. Using the screwdriver remove the oval label at the top of the unit and the tamper evident label in the center to enable access to all six screws fastening the back housing. Clean the adhesive remains of the tamper evident label using alcohol.
5. Using the Torx driver with the T-8 Torx bit, unscrew the six screws fastening the back housing.
6. Carefully remove the back housing from the unit.



**Installing the back housing:**

1. Position the back housing over the unit.
2. Verify that the cover is positioned correctly, screw holes are aligned to the threads of the front housing, external antenna connector is inserted into its dedicated hole, and the styling groove of the back housing meets the styling groove of the front housing.
3. Set the Torx driver to 3.5 in-lb (0.4 Nm).
4. Screw the back housing screws in the following order: Upper left and right screws, center left and right screws and lower left and right screws.
5. Glue a new oval label over the holes of the two upper screws and a new tamper evident label (\*only available to Motorola Services Centres) on the holes of the two center screws.
6. Install the battery and the battery door, refer to “Removing and Installing Battery Door and Battery”.
7. Install the antenna, refer to “Removing and Installing the Antenna”.

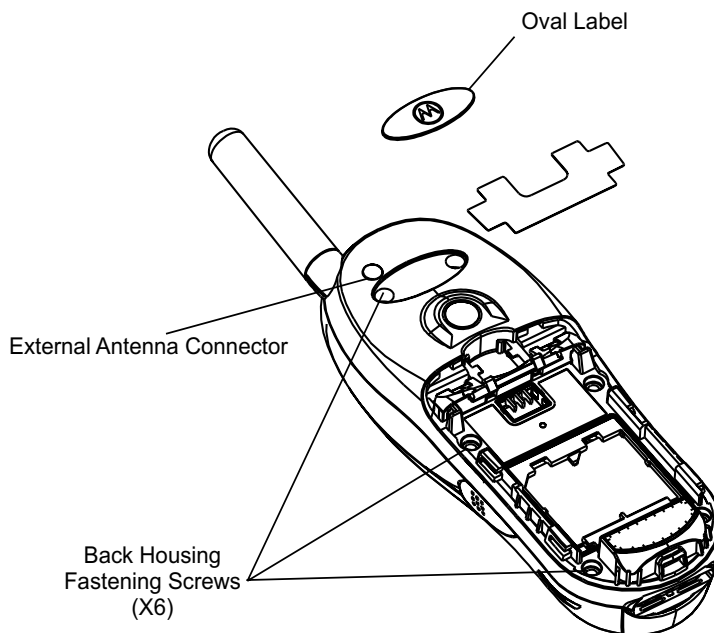

Figure 16 Back Housing Removal and Installation

## Removing and Installing the Vibrator

Recommended tools: mini flat-tip screwdriver

### Removing the vibrator:

(See Figure 17)

1. Remove the back housing, refer to “Removing and Installing the Back Housing”.
2. Turn the back housing up side down and, using the screwdriver, remove the vibrator from its chamber inside the back housing.

### Installing the vibrator:

1. Carefully push the vibrator into its chamber in the back housing.
2. Install the back housing, refer to “Removing and Installing the Back Housing”.

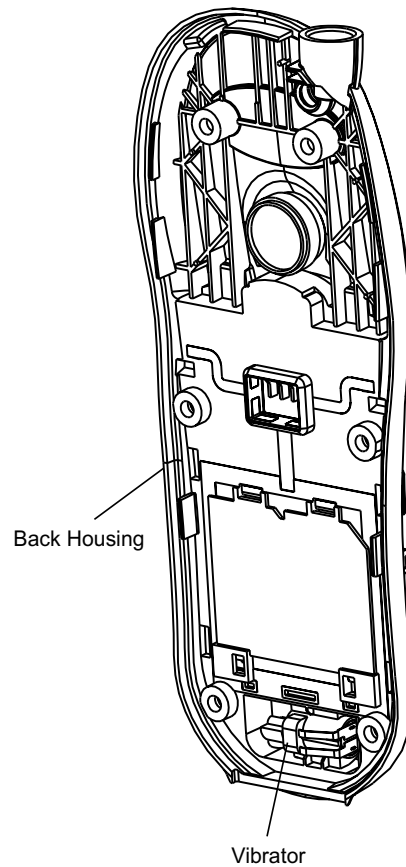

Figure 17 Vibrator Removal and Installation

## Removing and Installing the Main Board

Recommended tools: no tools are required

### Removing the main board from the unit:

(See Figure 18)

1. Remove the back housing, refer to “Removing and Installing the Back Housing”.
2. Gently lift the main board, I/O connector side at the bottom of the board first, and remove it from the unit.
3. Gently remove the rubber seal from the I/O connector, verify that the seal is not damaged (retain the seal for reinstallation).

### Installing the main board:

1. Gently install the rubber seal over the I/O connector.
2. Position the main board in location. Verify that the two guide pins are inserted into the holes in the main board.
3. Gently push the main board down and verify that the Board-to-Board connector is properly connected to the keypad board.
4. Verify that the I/O rubber seal is properly located in the unit.
5. Install the back housing, refer to “Removing and Installing the Back Housing”.

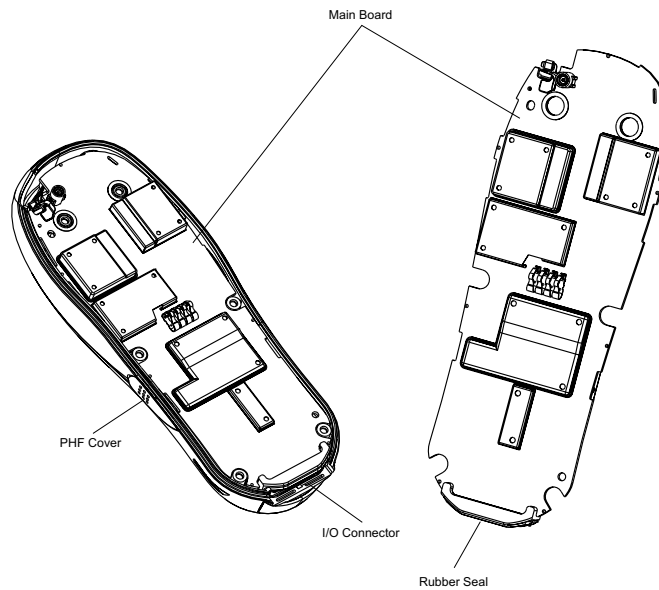

Figure 18 Main Board Removal and Installation

## Removing and Installing the Keypad and LCD Boards

Recommended tools: mini flat-tip screwdriver

### Removing the keypad and LCD boards from the unit:

(See Figure 19)

1. Remove the back housing, refer to “Removing and Installing the Back Housing”.
2. Place the unit facing down on the work area.
3. Open the Personal Hands-Free Kit (PHF) jack cover (See Figure 18).
4. Using the screwdriver, remove the chassis assembly including the main board, keypad board and LCD board, out from the unit.
5. Place the chassis assembly, with the keypad and LCD boards facing down, on the work area.
6. Remove the main board from the chassis assembly.
7. Insert the screwdriver into one of the slots in the upper side of the chassis assembly, above the LCD board, and gently push the boards out from the chassis assembly.
8. According to the board to be replaced, open the required Zero Insertion Force (ZIF) connector, release the flat cable and the board.

---

### Installing the keypad and LCD boards:

1. Place the keypad and LCD boards on the work area so that the ZIF connectors are facing up.

**CAUTION:** Care must be taken when installing the keypad and LCD boards on the chassis. Failure to comply may result in tear of the flat cable between the two boards.

2. Insert the flat cable into the ZIF connectors and close the connectors doors until a click is heard.
3. Insert the LCD board between the two snags at the sides of the chassis assembly.
4. Push the LCD board down until it snaps into location.
5. Verify that the chassis center guide pin is properly located inside the hole in the LCD board and that the snag at the top of the chassis is inserted into the slot of the board.
6. Install the keypad board on the chassis assembly.
7. Verify that the keypad board is sited parallel to the chassis assembly.
8. Verify that the main board is fully installed with the rubber seal.
9. Turn the chassis assembly up side down.
10. Install the main board on the chassis assembly. Verify that the two guide pins are inserted to the holes in the main board.
11. Verify that the guide pins are properly located and that the Board-to-Board connector is properly connected to the main board.
12. Install the chassis assembly with the boards into the unit. Verify that the I/O connector rubber seal is properly located in the unit.
13. Install the back housing, refer to “Removing and Installing the Back Housing”.

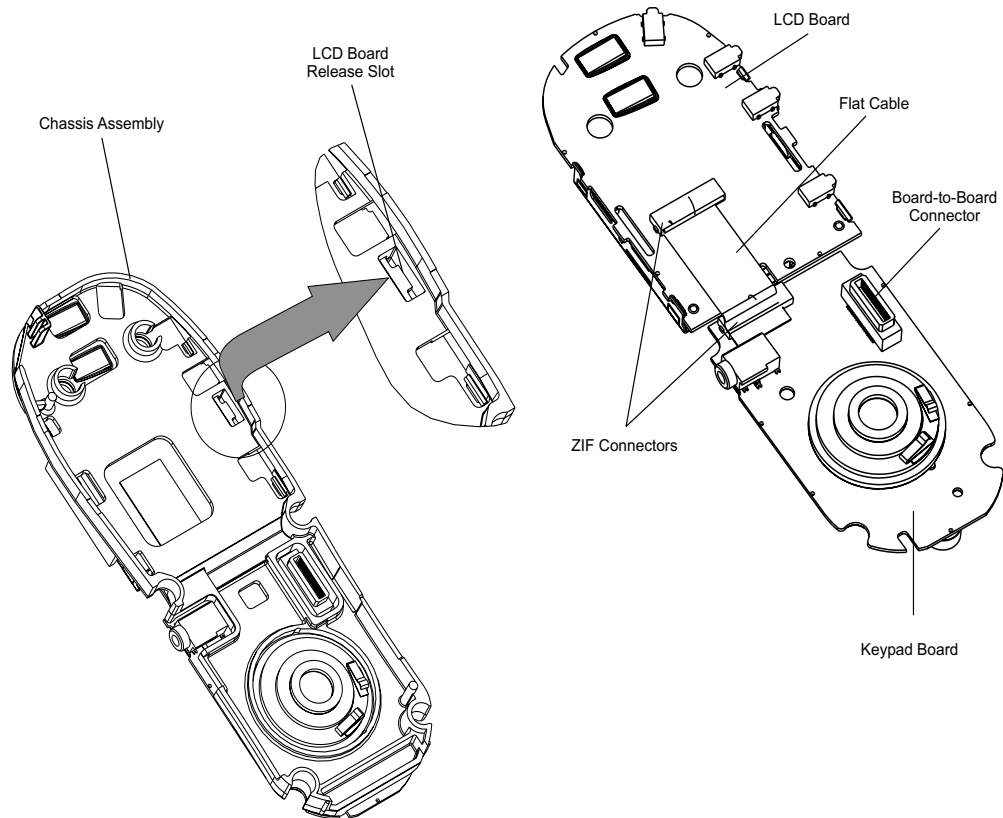

Figure 19 Keypad and LCD Boards Removal and Installation

## Removing and Installing the LCD Module Assembly

Recommended tools: no tools are required

### To remove the LCD module assembly from the unit:

(See Figure 20)

1. Remove the LCD board, refer to “Removing and Installing the Keypad and LCD Boards”

NOTE: *Do not* touch the LCD module assembly in the active viewing area; fingerprints on this surface cannot be easily removed.

2. Using your hand, gently disengage the right two snaps and rotate the LCD module assembly to the left until it disengaged from the LCD board.

**To install the LCD module assembly:**

NOTE: *Do not* touch the LCD module assembly in the active viewing area; fingerprints on this surface cannot be easily removed.

1. Locate the LCD module above the LCD board so that the two guide pins are aligned with the holes in the LCD board.
2. Gently push the module down, right snaps first and then left snaps.
3. Verify that the snaps are located correctly inside the board slots.
4. Remove the protective film from the LCD glass. Verify that no damage exists on the LCD glass.
5. Install the LCD board, refer to “Removing and Installing the Keypad and LCD Boards”.

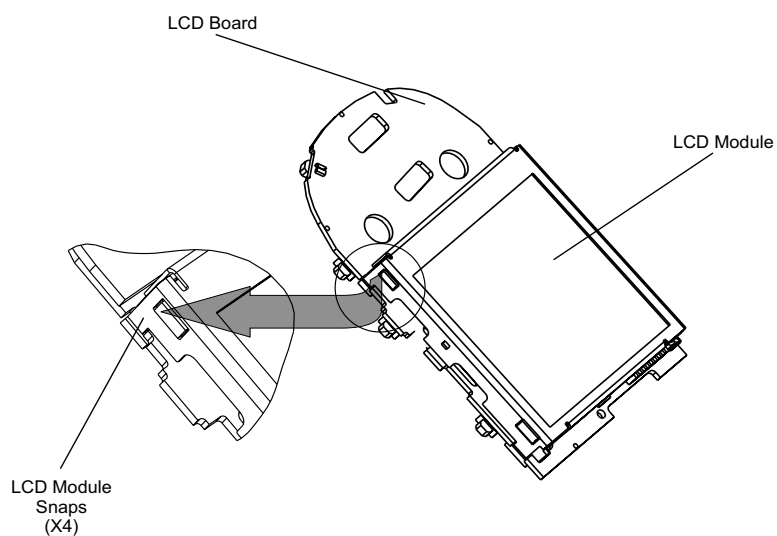

Figure 20 LCD Module Removal and Installation

## Removing and Installing the Keypad

Recommended tools: no tools are required

### Removing the keypad:

(See Figure 21)

1. Remove the chassis assembly, refer to “Removing the keypad and LCD boards from the unit:”, steps 1 through 3.
2. Remove the keypad from the unit.

### Installing the keypad:

1. Install the keypad inside the front housing.
2. Verify that all the keys are properly inserted into their dedicated holes.
3. Install the chassis assembly, refer to “Installing the keypad and LCD boards:”, steps 1 and 2.

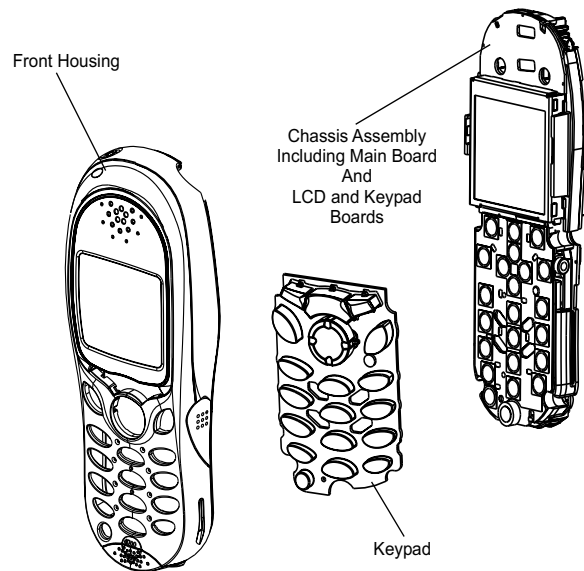

Figure 21 Keypad Removal and Installation



---

## Removing and Installing the Microphone

Recommended tools: no tools are required

### Removing the microphone:

(See Figure 22)

1. Remove the chassis assembly, refer to “Removing the keypad and LCD boards from the unit:”, steps 1 through 3.
2. Remove the microphone.

### Installing the microphone:

1. Insert a microphone into location.
2. Install the chassis assembly, refer to “Installing the keypad and LCD boards:”, steps 1 and 2.

## Removing and Installing the Earphone

Recommended tools: mini flat-tip screwdriver

### Removing the earphone:

(See Figure 22)

1. Remove the Acoustic Safety Rubber.
2. Remove the chassis assembly, refer to “Removing the keypad and LCD boards from the unit:”, steps 1 through 3.
3. Using the screwdriver, remove the earphone from the unit. If the earphone was detached from its bottom plate, remove the plate as well.

### Installing the earphone:

1. Install the Acoustic Safety Rubber.
2. Using the screwdriver, remove the protective film from the adhesive layer at the earphone bottom plate.
3. Insert the earphone into location. Verify that the two snags at the earphone sides are properly located in their dedicated slots.
4. Gently push the earphone until it is firmly glued inside the front housing.

5. Install the chassis assembly, refer to “Installing the keypad and LCD boards:”, steps 1 and 2.

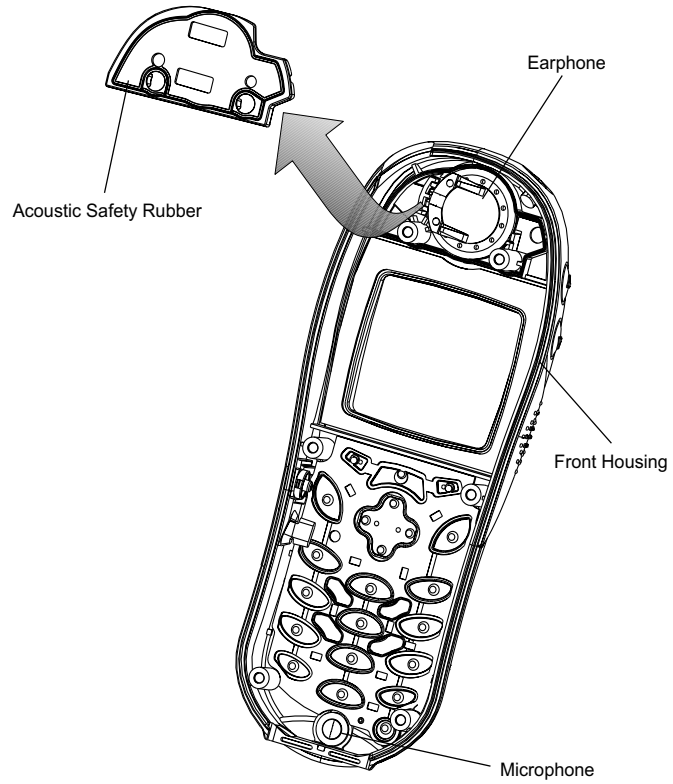

Figure 22 Microphone and Earphone Removal and Installation

## MTH500 Unit - Exploded View

MTH500 components are listed in the “MTH500 Components List”. The first column marked with an # sign provides you with the call out numbers of the components as marked in Figure 23 and Figure 24.

### MTH500 Components List

#	Description	Part/Kit
1	Front Housing Assembly (Black) Front Housing Assembly (Blue)	0186163T07 0186163T08
2	Keypad Assembly	0186630T01
3	Chassis Assembly	See Figure 23
4	Back Housing Assembly (Black) Back Housing Assembly (Blue)	0186396T04 0186396T05
5	Antenna 380-400 M Hz (R1)	8586381J02
6	Screw, Self Forming	0304637P17
7	Label, Back	5486278T01
8	Standard Battery Door Assembly (Black) Standard Battery Door Assembly (Blue)  Extended Battery Door Assembly (Black) Extended Battery Door Assembly (Blue)	0186613T01 0186613T02  0186239T01 0186239T02
9	LCD Module	7287702M01
10	Keypad Kit	FCN9090A
11	Flex LCD to Keypad	8486498T01
12	LCD Kit	FCN9797A
13	Chassis	2786168T01
14	Main Board (R2)	See Service Replacement Kit Matrix in Appendix A

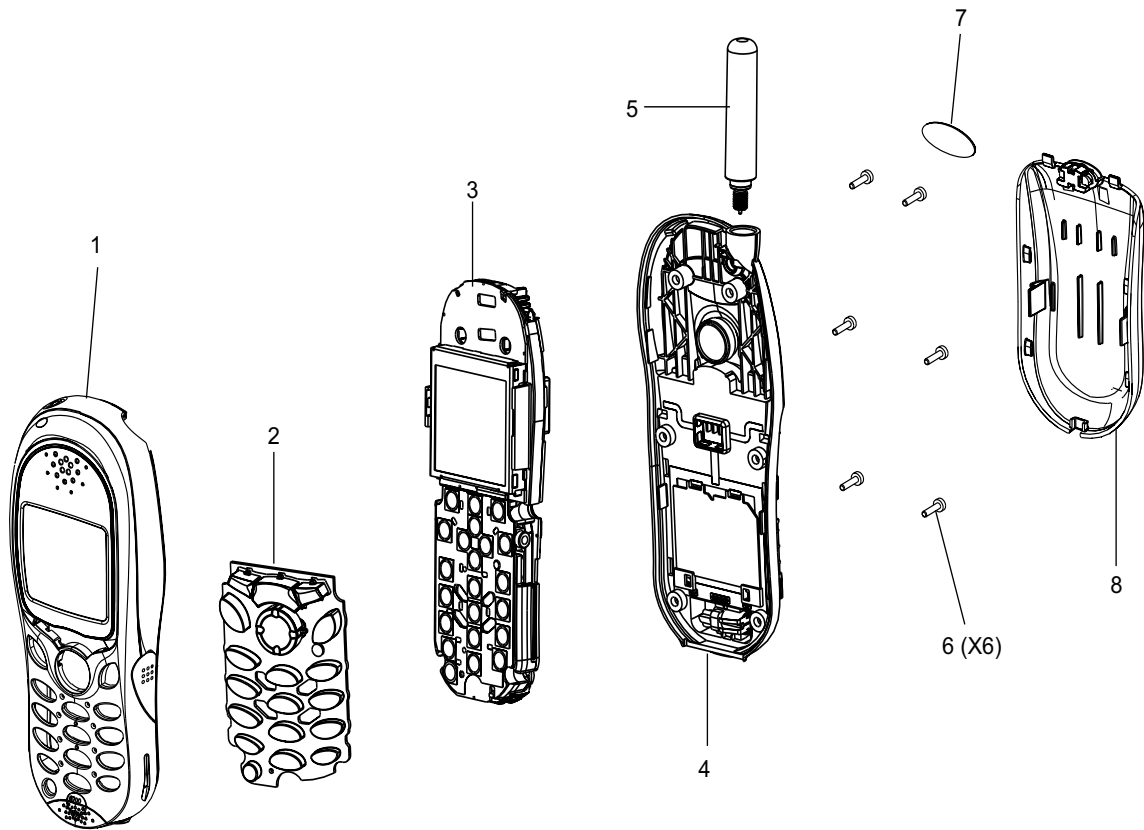

Figure 23 Exploded View

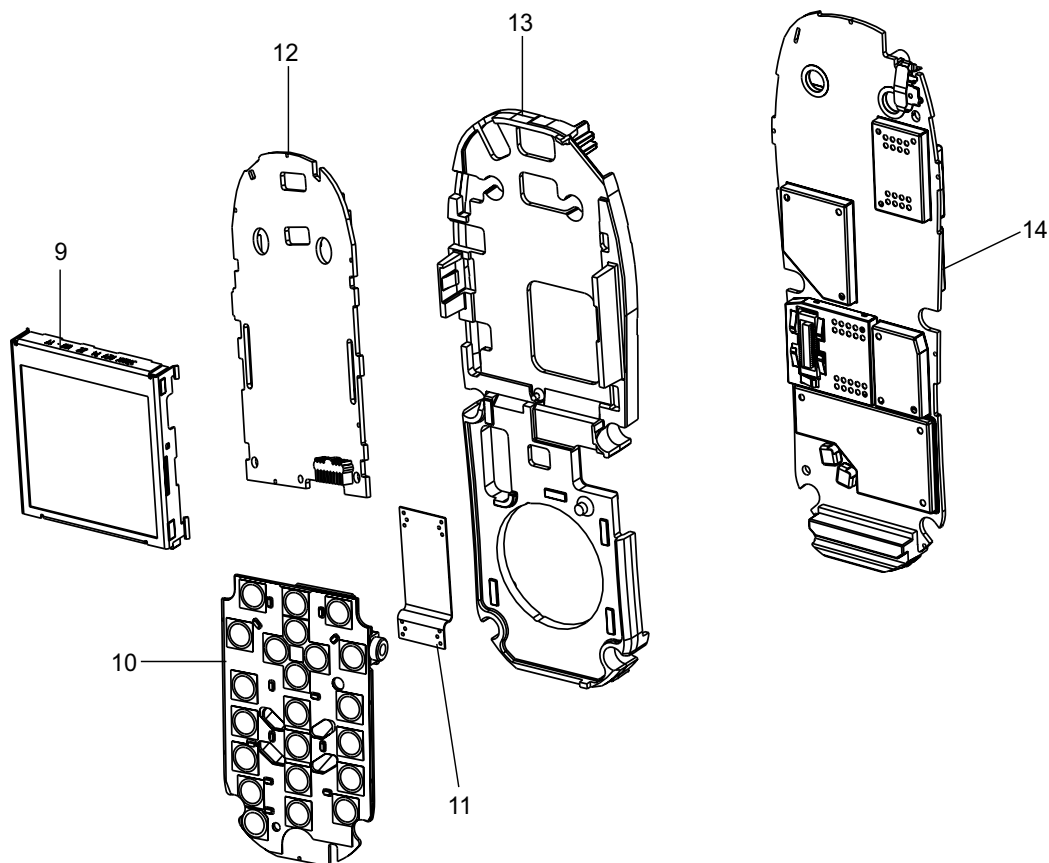

Figure 24 Exploded View of Chassis Assembly



## Component Board Layouts

---

This page intentionally left blank



Keypad Board (FCN9090A) - Sides 1 and 2

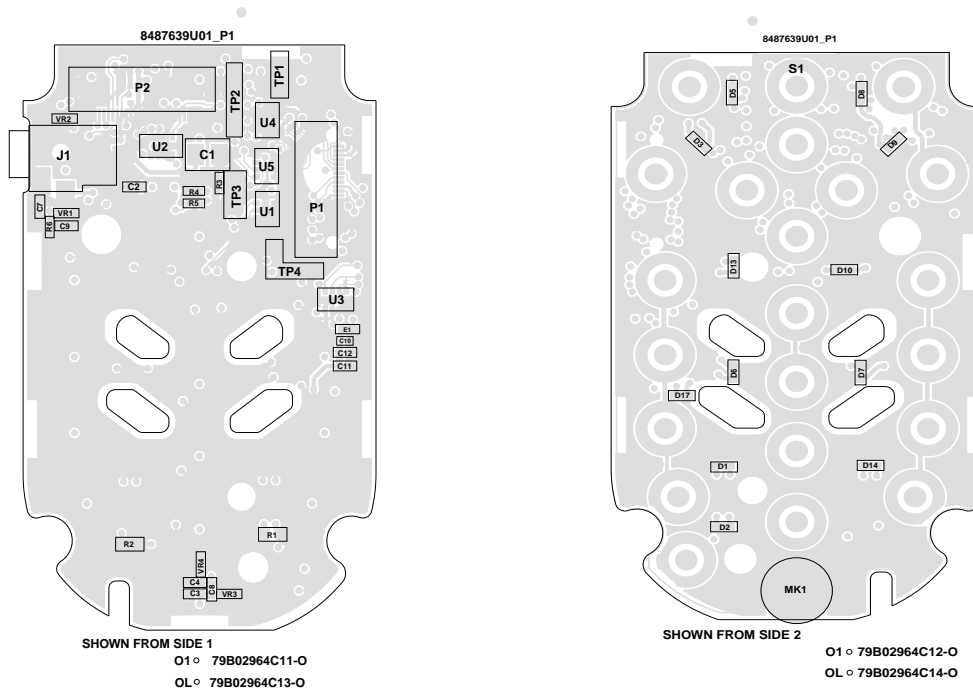

LCD Board (FCN9797A) - Side 1 and 2

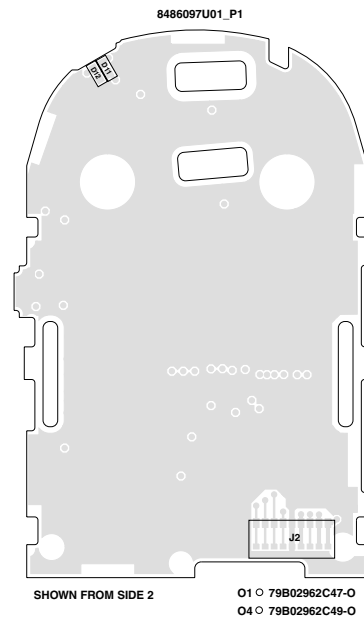
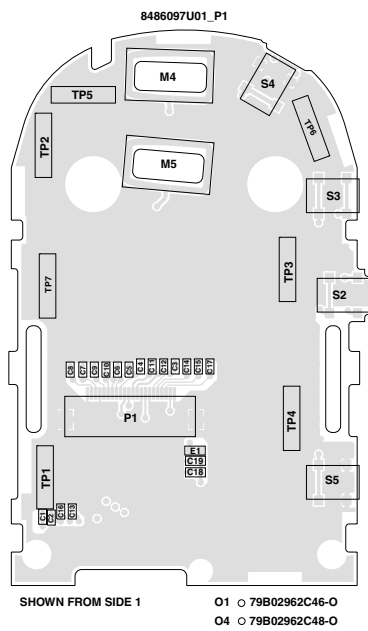

Main Board (FLF9011A) - Side 1

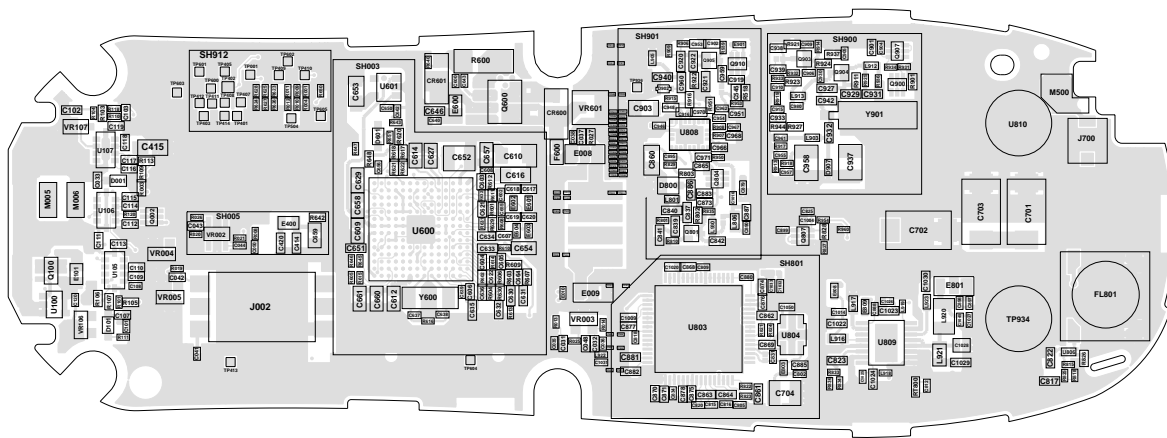

SHOWN FROM SIDE 1

- O1 o 73B02964C21-O
- OL o 73B02964C24-O

Main Board (FLF9011A) - Side 2

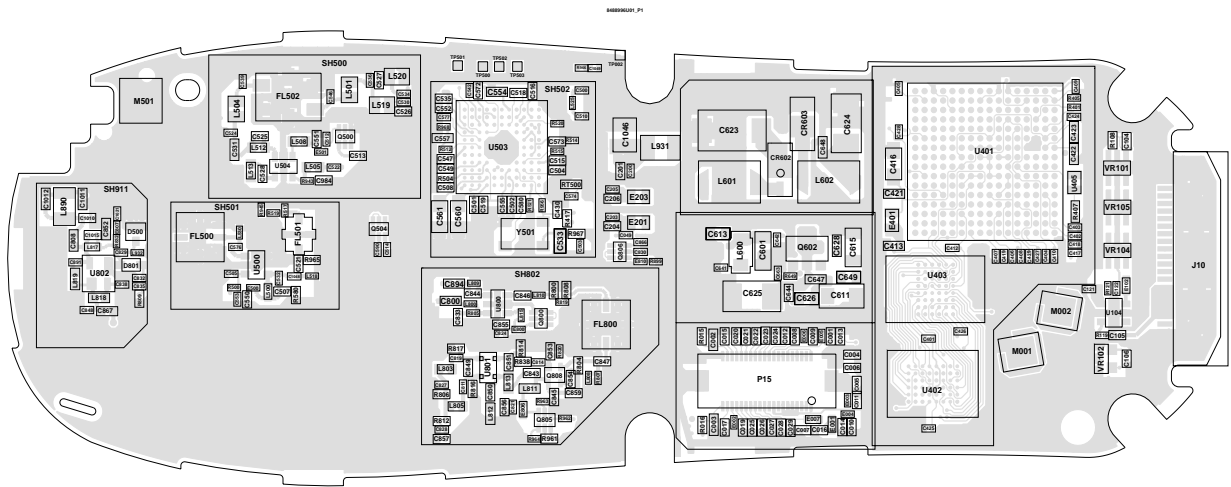

SHOWN FROM SIDE 2

- O1 o 73B02964C22-O
- OL o 73B02964C24-O

## Schematic Diagrams and Parts Lists

---

MTH500 Keypad Board (FCN9090A)

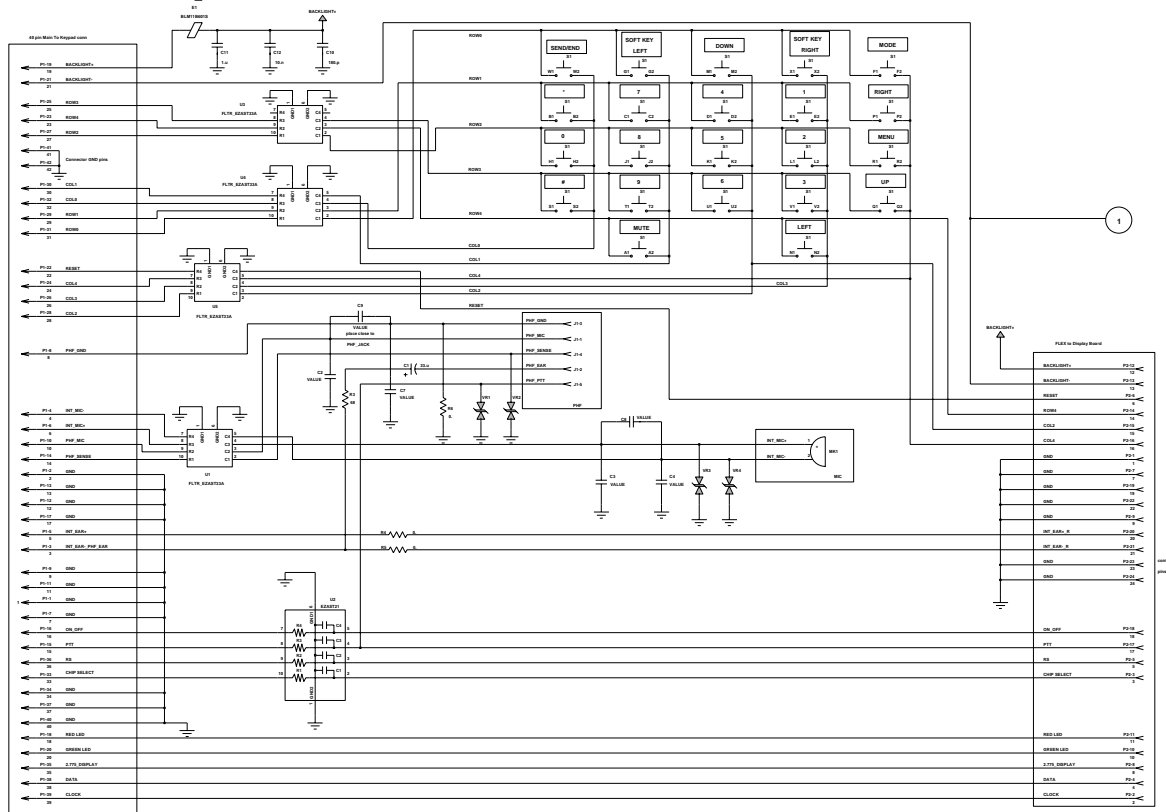

## MTH500 Keypad Board (FCN9090A) Component Parts

When ordering component parts, the part number should be included.

CAPACITORS			CONNECTOR and INDUCTORS			RESISTORS		
Ref #	Part #	Description	Ref #	Part #	Description	Ref #	Part #	Description
C1	2311049A30	Tant. chip 33µF	J1	0985885K01	conn.J			
C2	9186929J02	400&880MHz resonance Cap.	P1	0986926J03	conn.J			
C3	9186929J02	Part not placed	P2	0986966J01	conn.J	INTEGRATED CIRCUITS		
C4	9186929J02	400&880MHz resonance Cap.						
C7-9	9186929J02	Part not placed	GENERAL			Ref #	Part #	Description
C10	2113743P01	Part not placed	Ref #	Part #	Description	U1	9186133U02	FLTR_EZAST3 3A
C11	2113928A01	1µF				U2	9185759B01	EZAST21
C12	2113741F49	10nF	MK1	5086346J02	Part not placed	U3-5	9186133U02	FLTR_EZAST3 3A
DIODES			RESISTOR					
Ref #	Part #	Description	Ref #	Part #	Description	ZENER DIODES		
			R1-2	0662057C43	res_47 Ohm	Ref #	Part #	Description
LED			R3	0662057A21	res_68 Ohm	VR1-4	4804645P09	Suppr. 6V
Ref #	Part #	Description	R4-5	0662057A18	res_51 Ohm			
D1	4886955J02	Part not placed	R6	0662057B47	res_0 Ohm			
D2-3	4886955J02	LED_grn	S1	9997639U01	Keypad_22			
D5	4886955J02	LED_grn						
D6	4886955J02	Part not placed						
D7-10	4886955J02	LED_grn						
D13-14	4886955J02	LED_grn						
D17	4886955J02	LED_grn						
E1	2409134J04	BLM11B6016						

MTH500 LCD Board (FCN9797A)

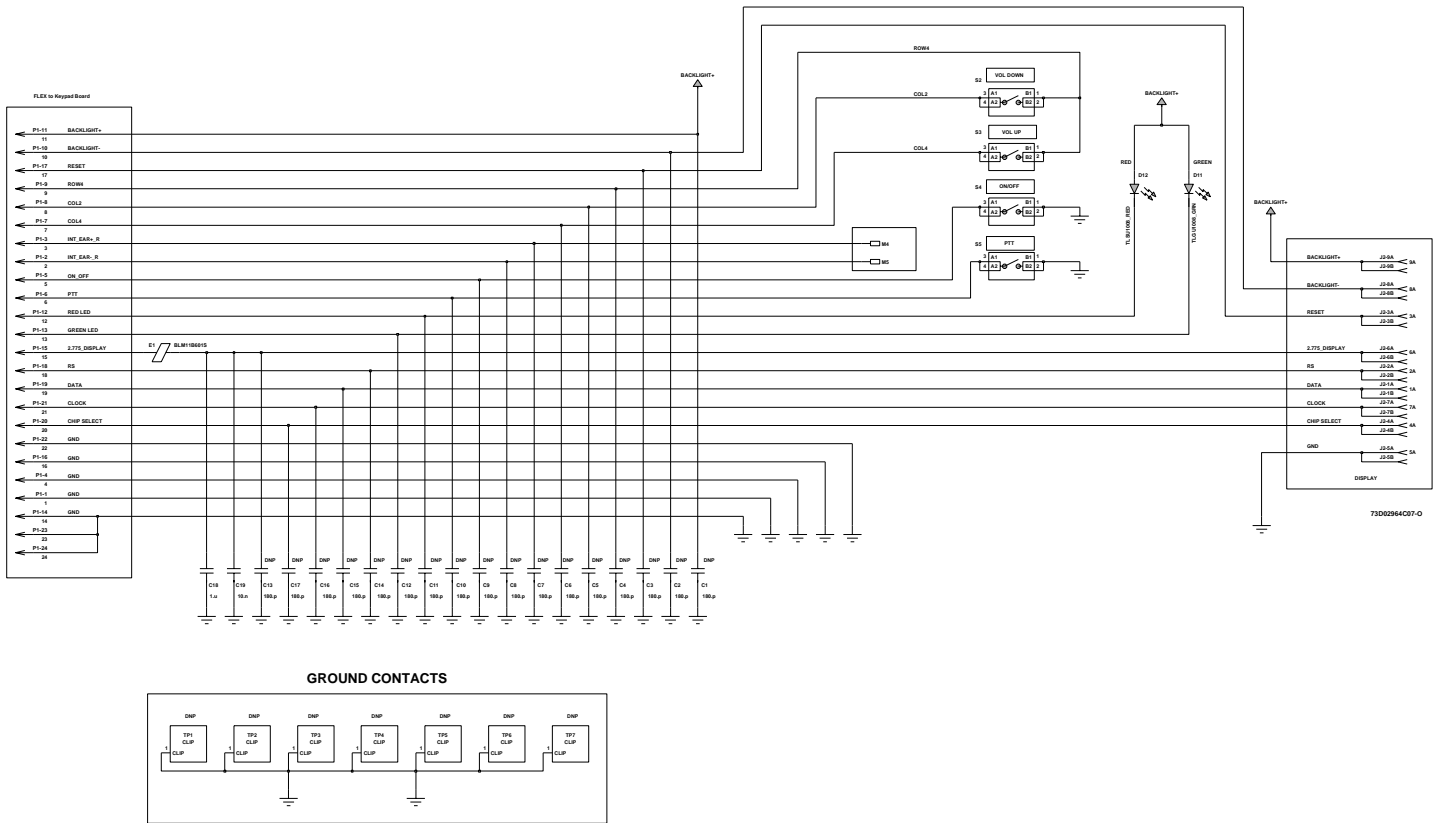



### MTH500 LCD Board (FCN9797A) Component Parts

When ordering component parts, the part number should be included.

CAPACITORS			RECEPTOR			RESISTORS		
Ref #	Part #	Description	Ref #	Part #	Description	Ref #	Part #	Description
C1-17	2113743p01	Part not placed						
C18	2113928A01	1µF	GENERAL					
C19	2113741F49	10nF	Ref #	Part #	Description	INTEGRATED CIRCUIT - AUDIO		
			M4-5	3986295T01	Contact	Ref #	Part #	Description
			S2-5	4086218A02	Switch			
			TPI-7	4209080u02	Part not placed			
DIODES			RESISTOR					
Ref #	Part #	Description	Ref #	Part #	Description			
LED								
Ref #	Part #	Description						
D11	4886955j02	LED_gm						
D12	4886955j01	LED_red						
CONNECTOR and INDUCTORS								
Ref #	Part #	Description						
E1	2409134j04	Ind. chip fer.						
J2	0988189K02	conn_J						
P1	0986966j01	conn_J						

MTH500 MAIN Board (FLF9011A)

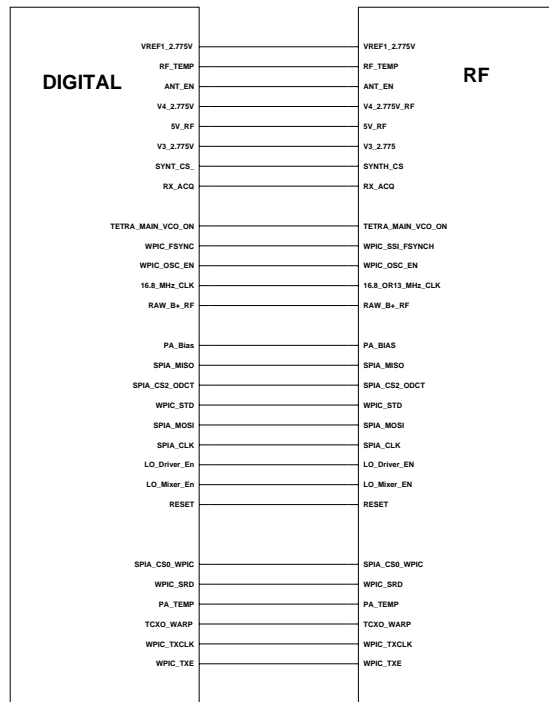

79802964C09-0  
SHEET 1 OF 9

MTH500 Main RF Block

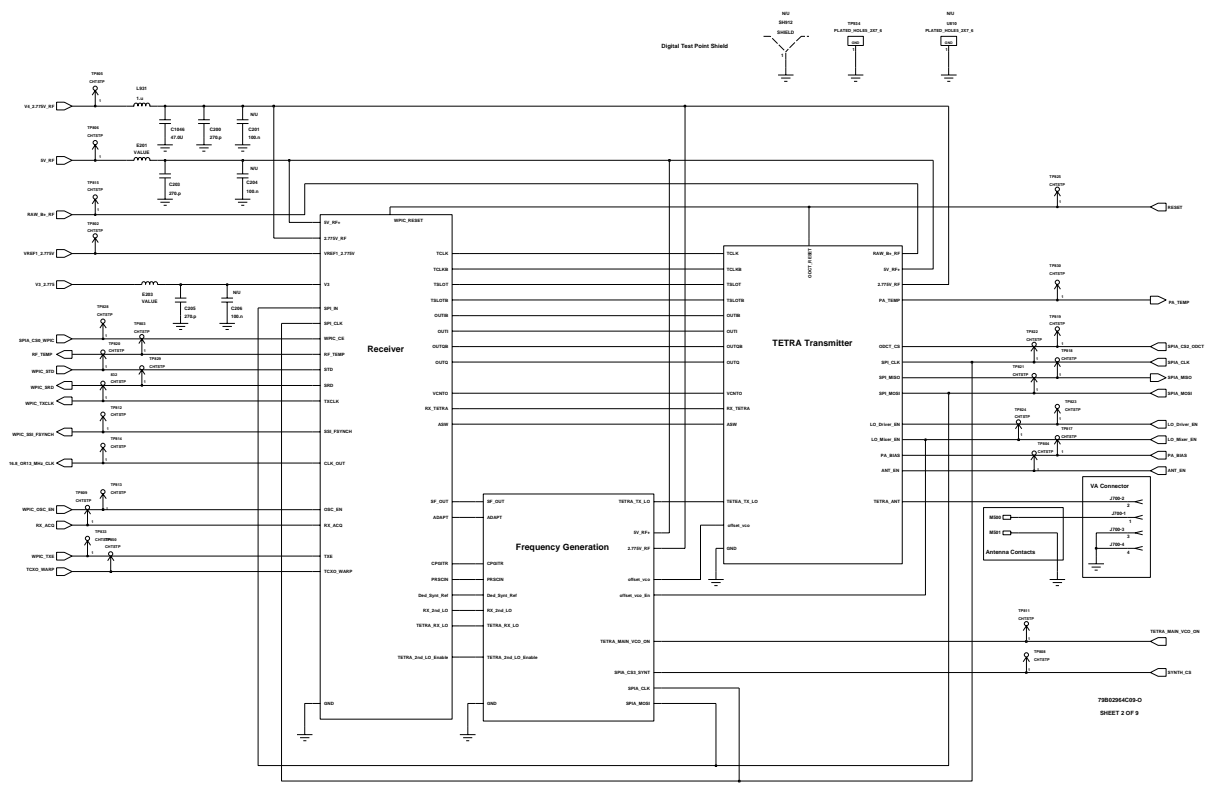

MTH500 Transmitter Block (Sheet 1 of 2)

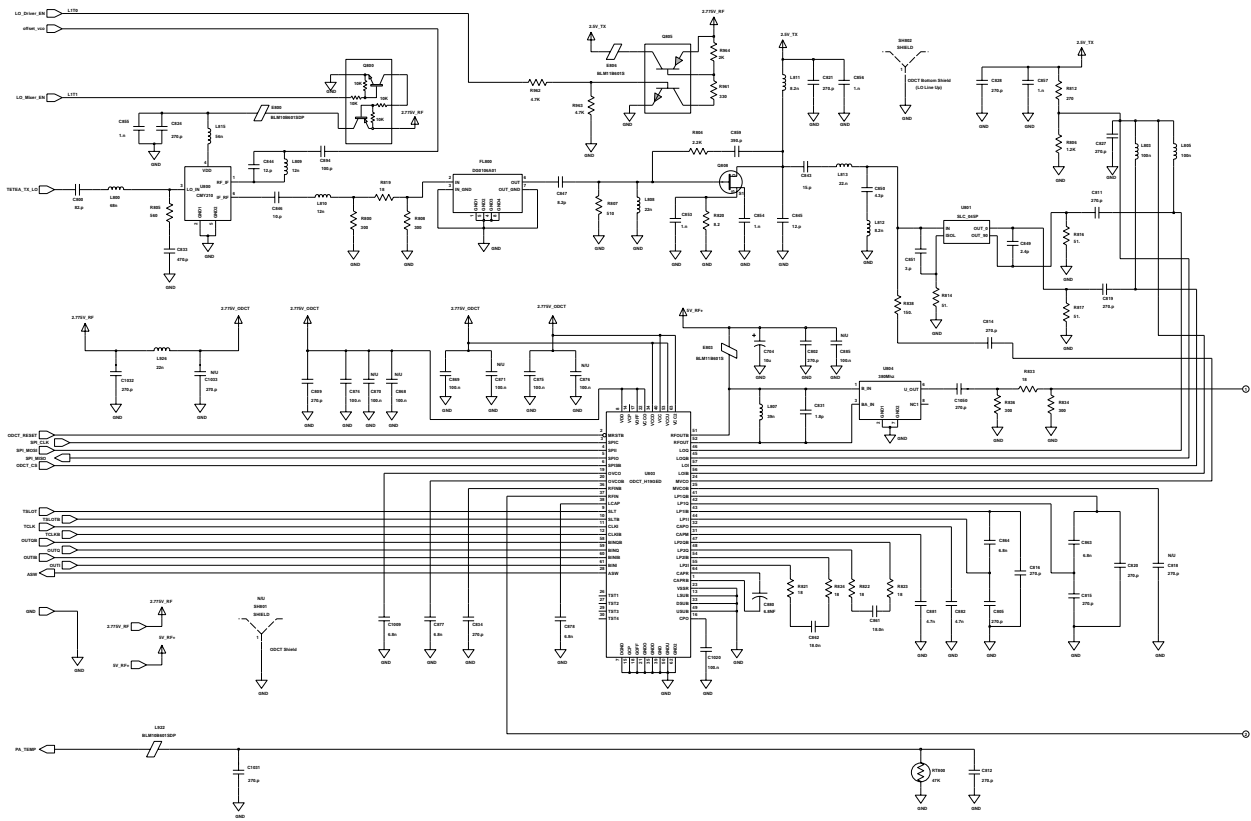

MTH500 Transmitter Block (Sheet 2 of 2)

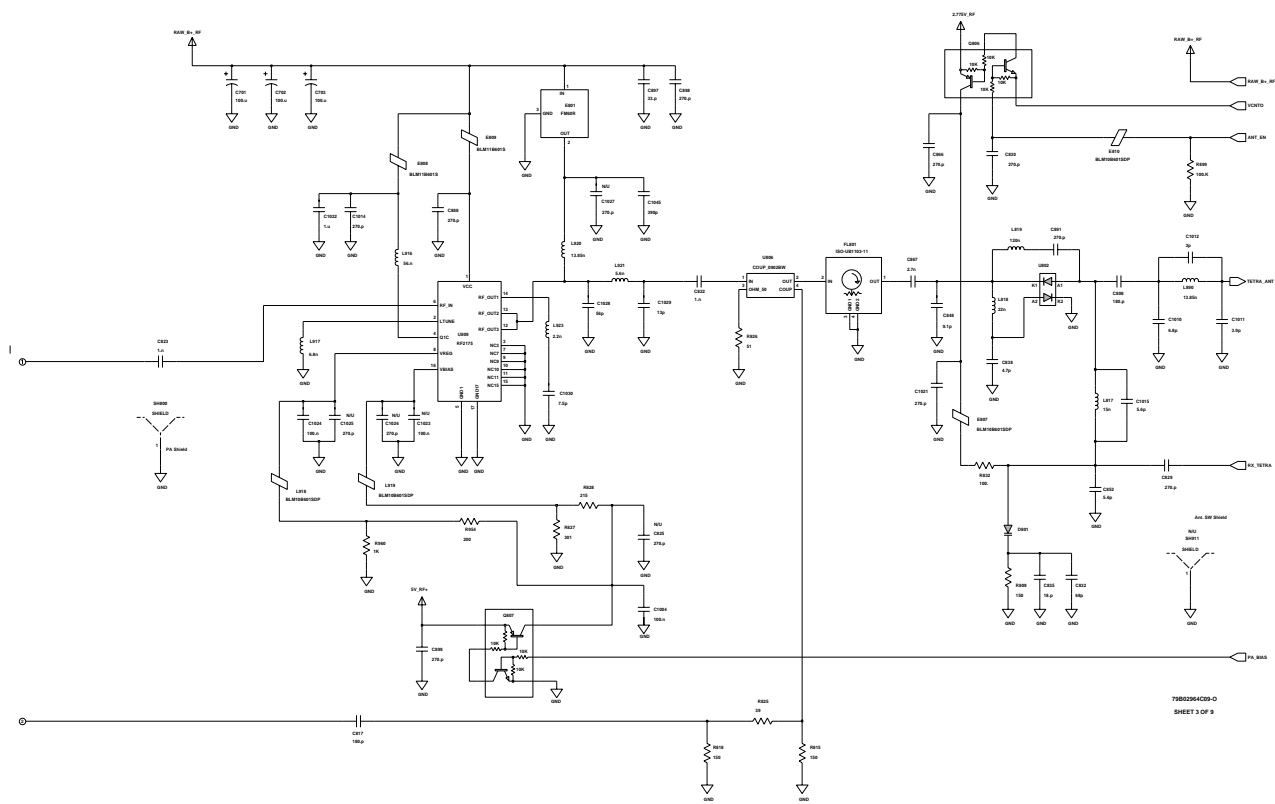

MTH500 Receiver Block (Sheet 1 of 2)

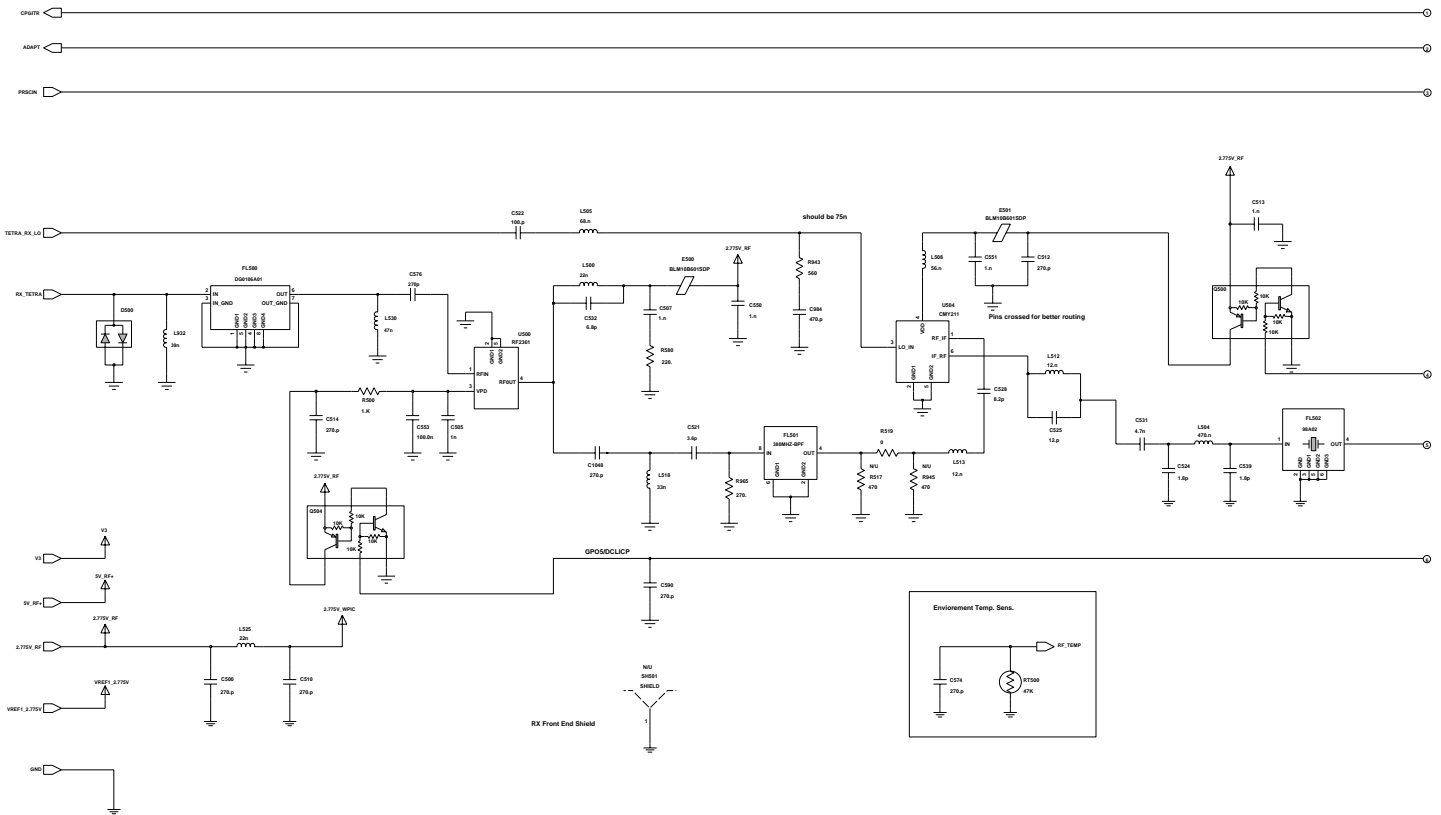

### MTH500 Receiver Block (Sheet 2 of 2)

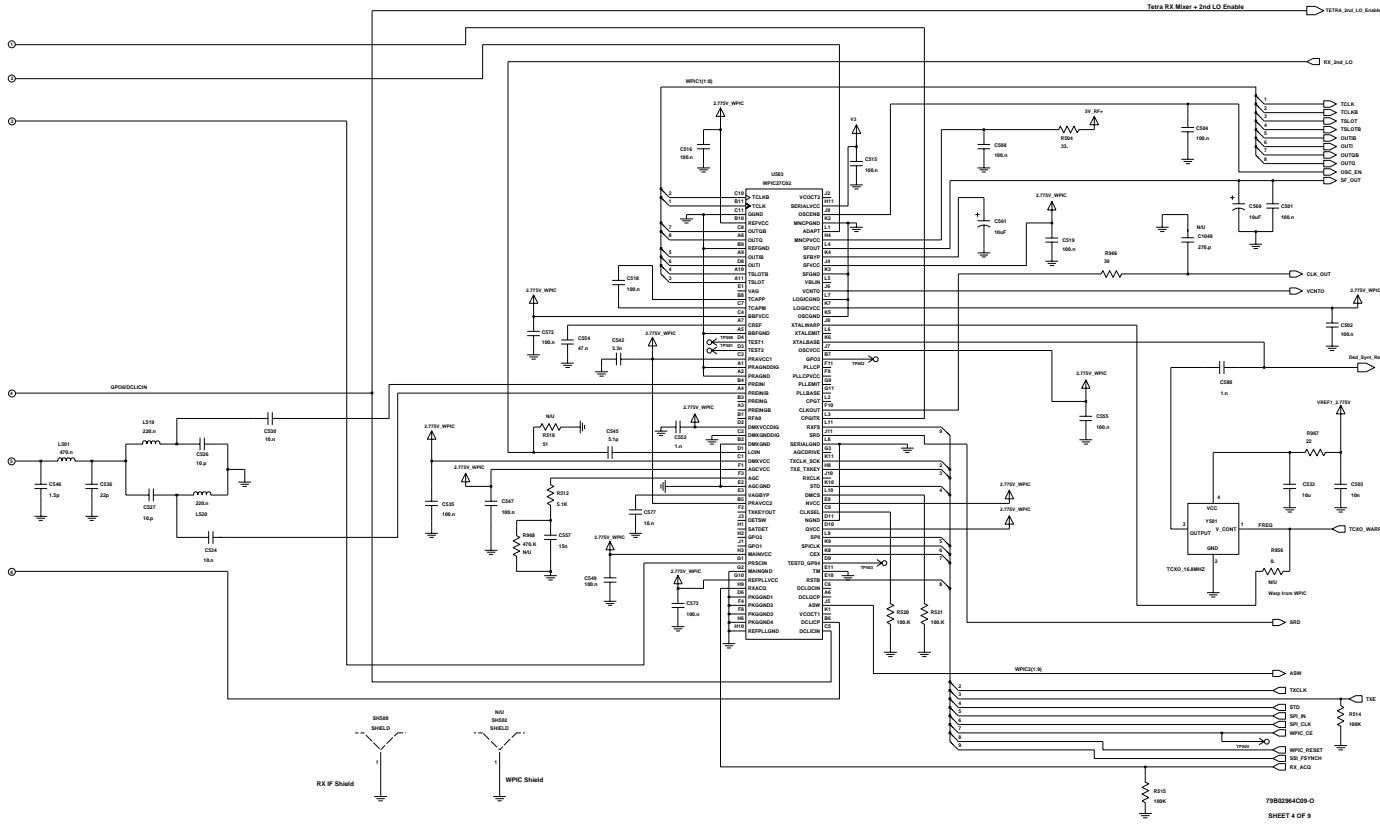

68P02963C70-0

MTH500 Frequency Block Tetra Main VCO (Sheet 1 of 2)

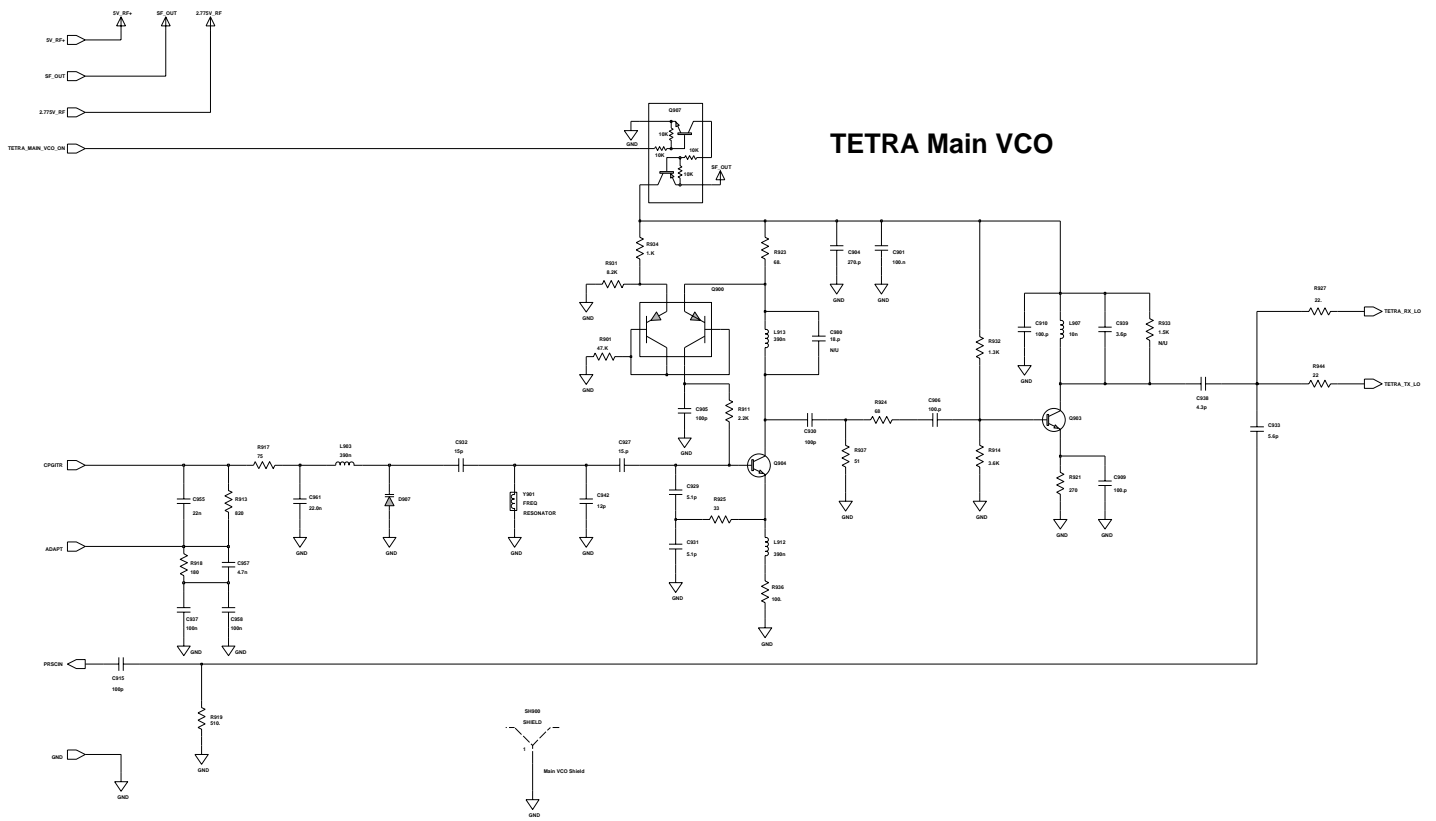



MTH500 Frequency Generation Block, Offset VCO (Sheet 2 of 2)

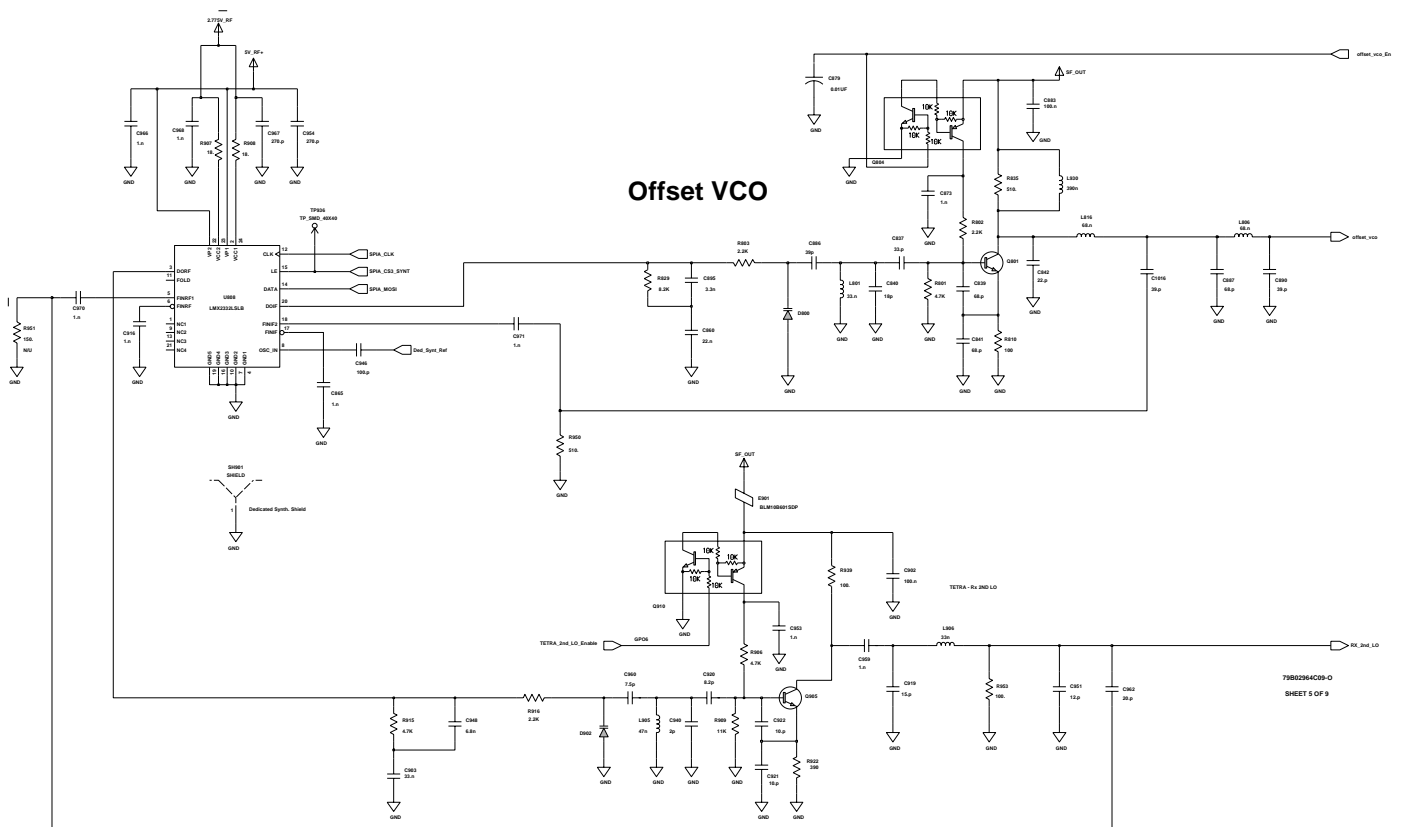

MTH500 Main Digital Block (Sheet 1 of 2)

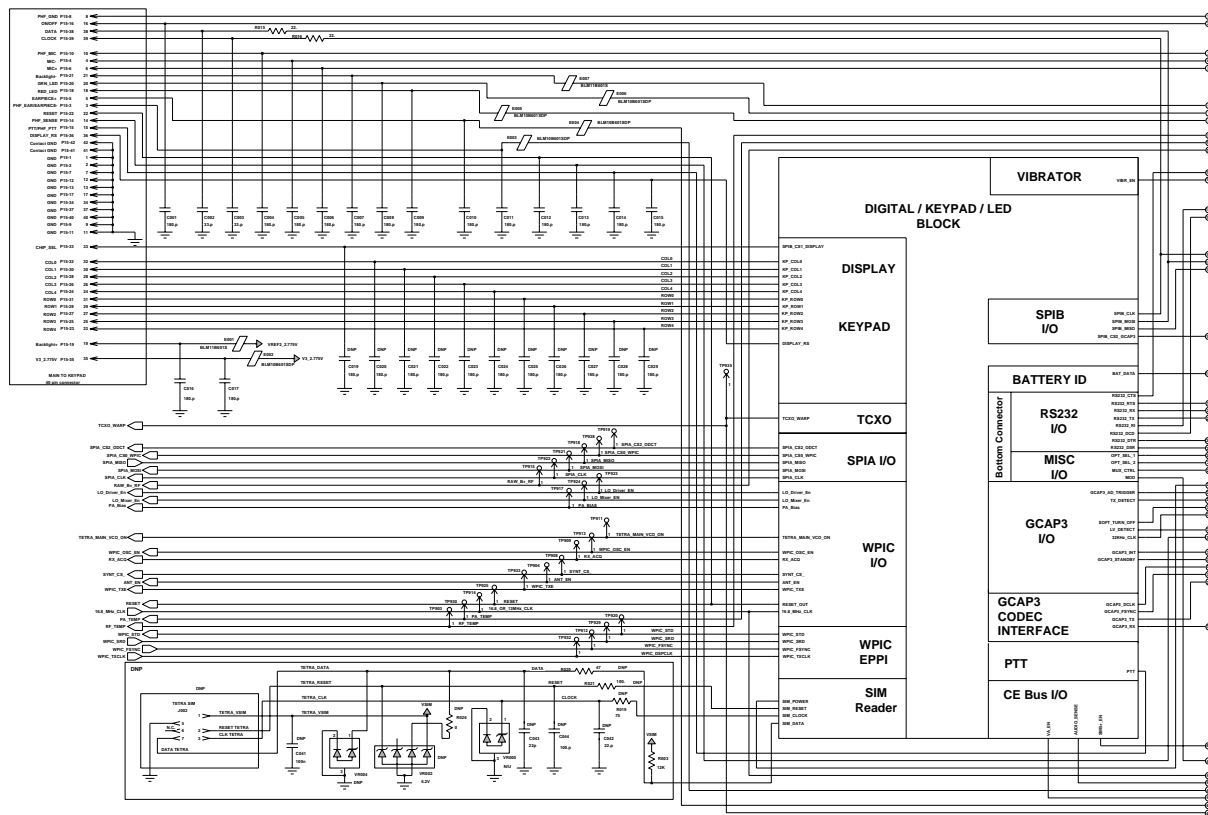

MTH500 Main Digital Block (Sheet 2 of 2)

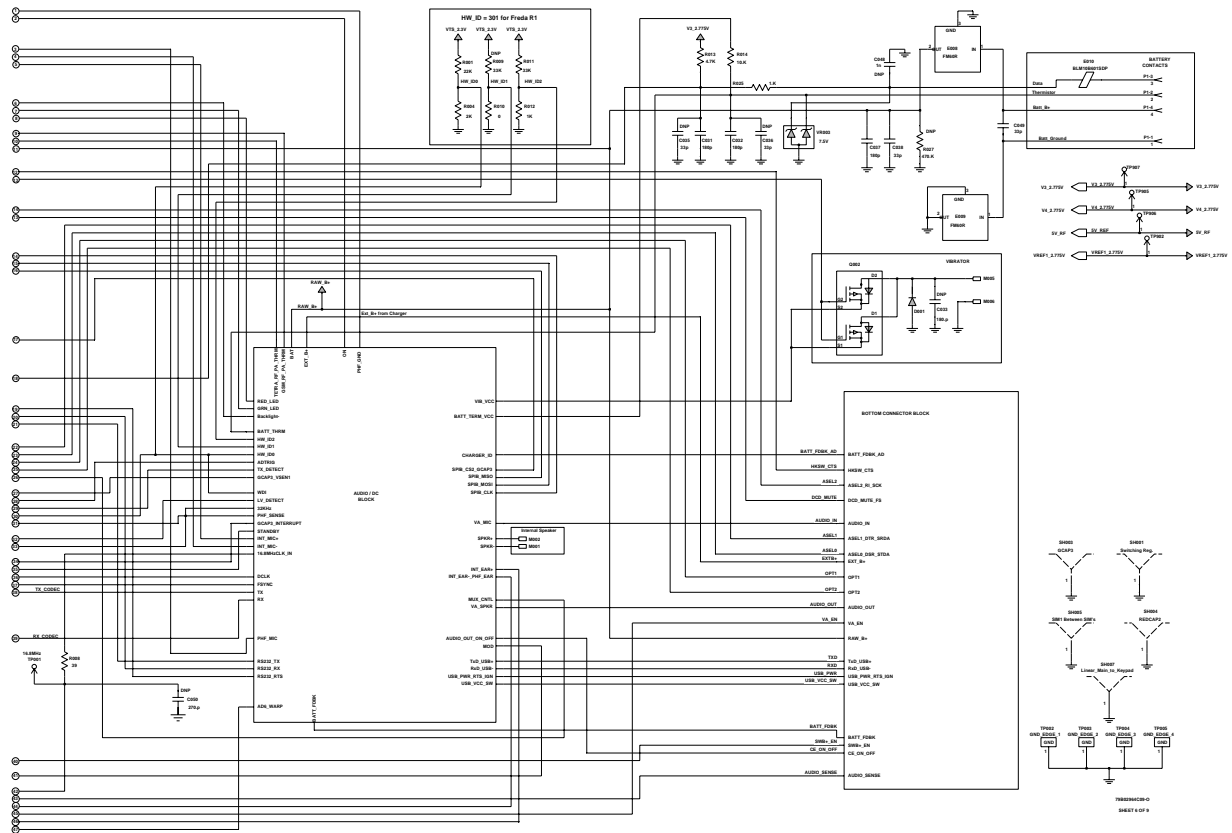

MTH500 Audio & DC Block (Sheet 1 of 2)

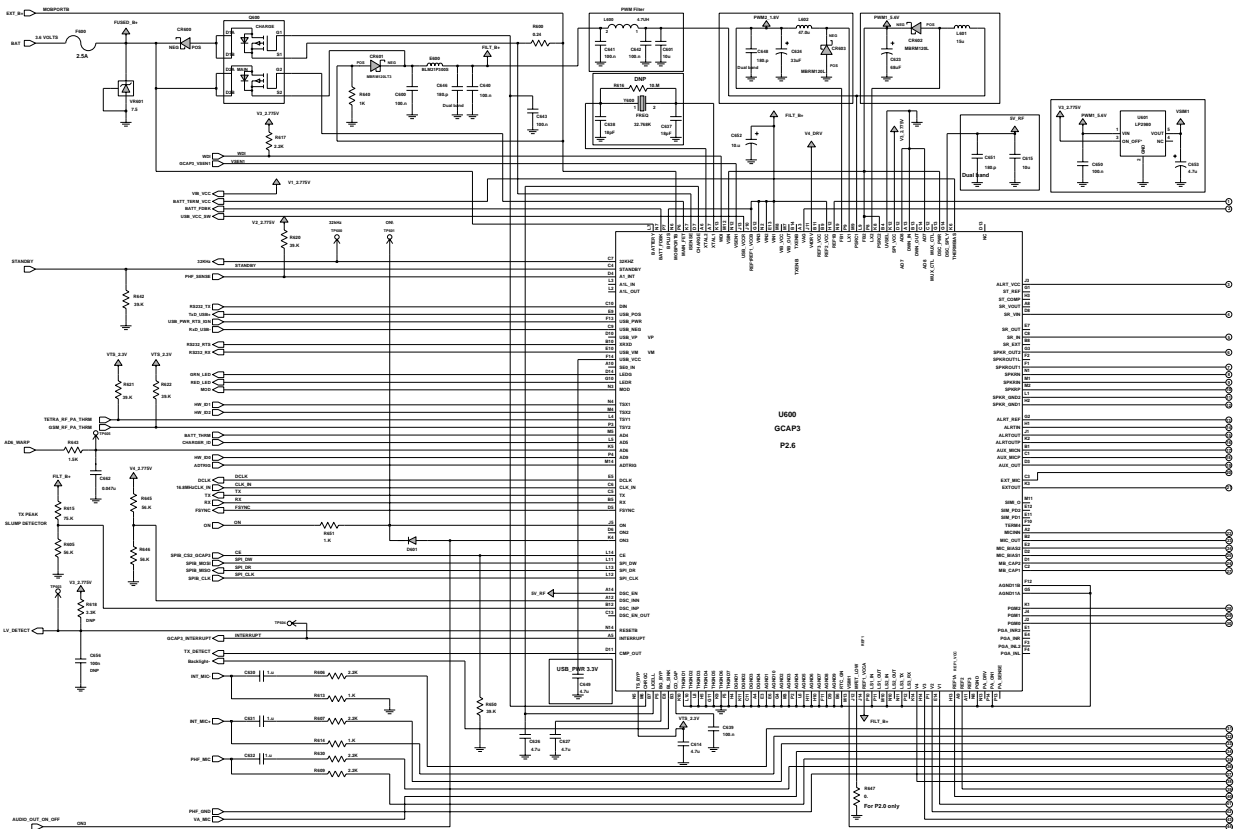

MTH500 Audio & DC Block (Sheet 2 of 2)

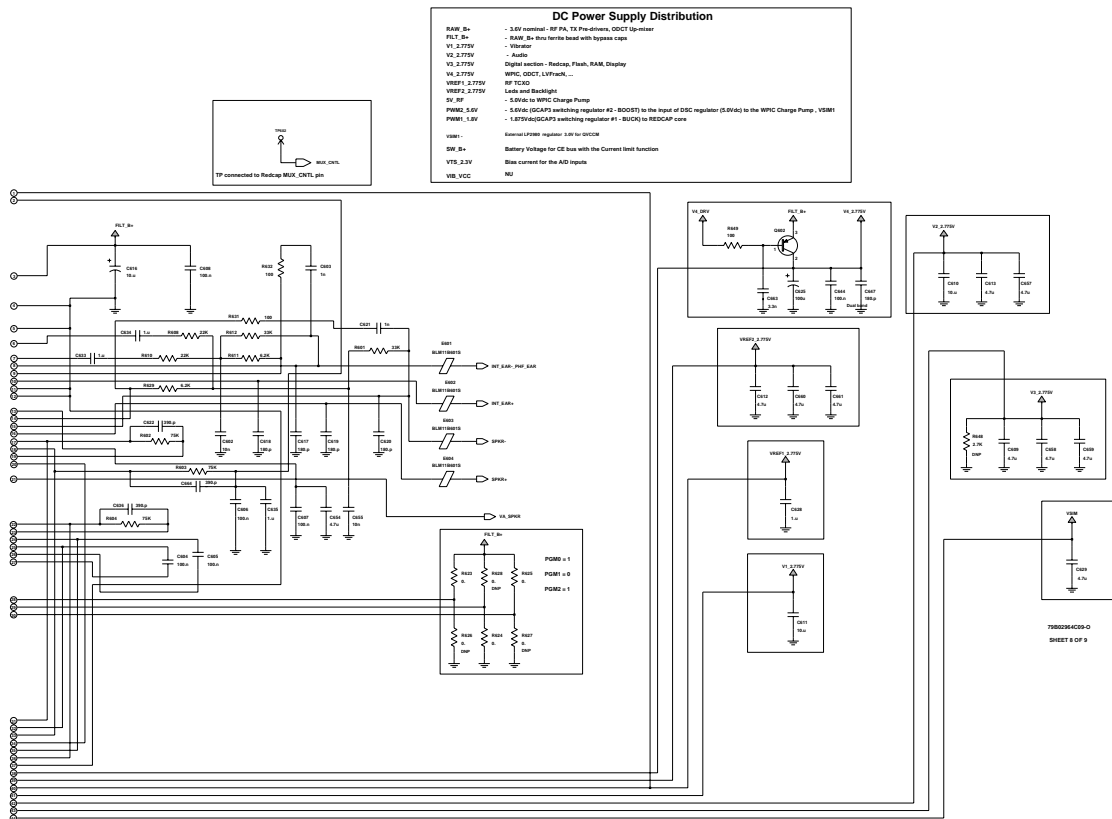

MTH500 REDCAP 2 Block (Sheet 1 of 2)

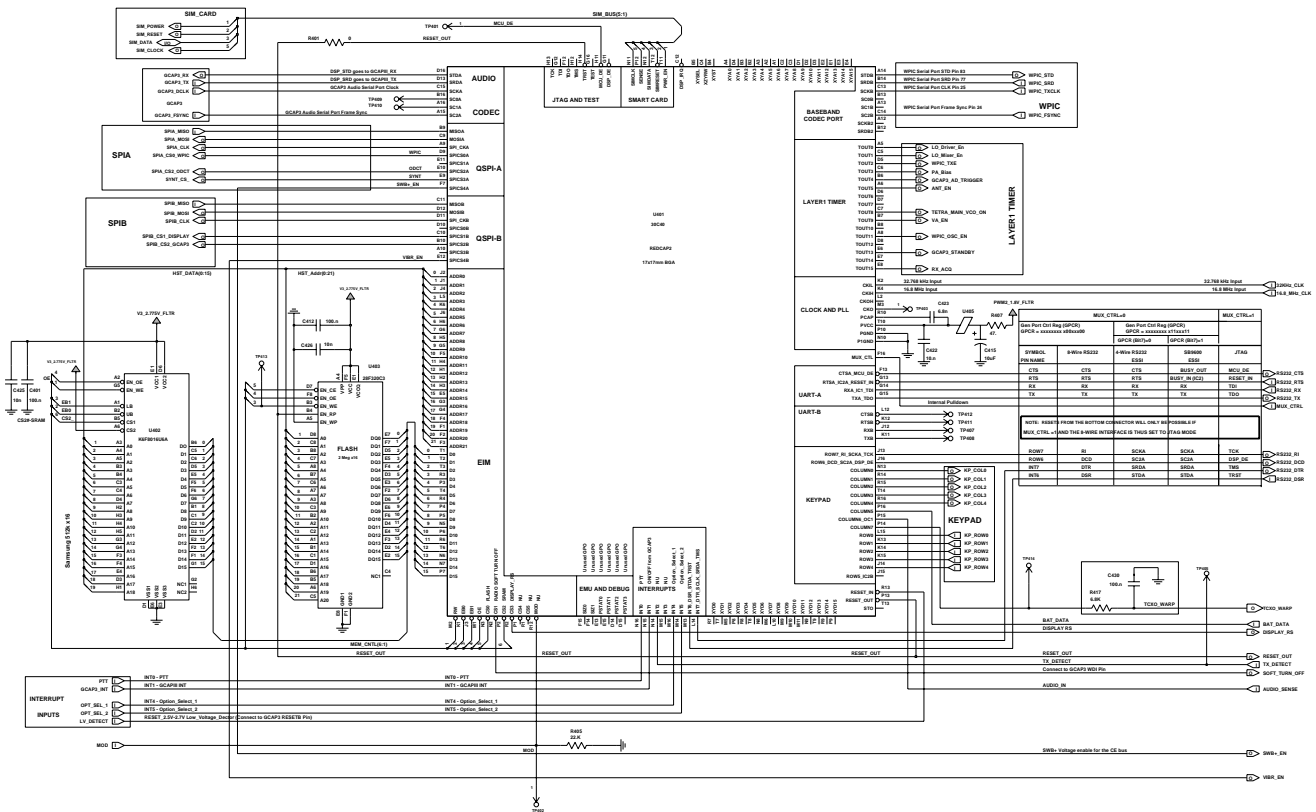

MTH500 REDCAP 2 Block (Sheet 2 of 2)

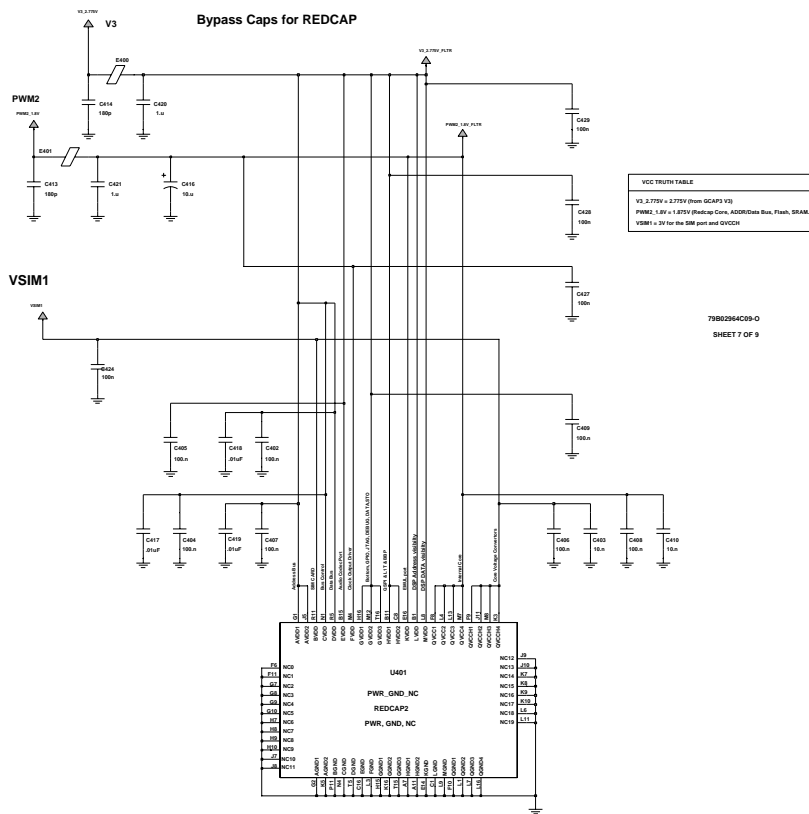

MTH500 Accessory Connector Block

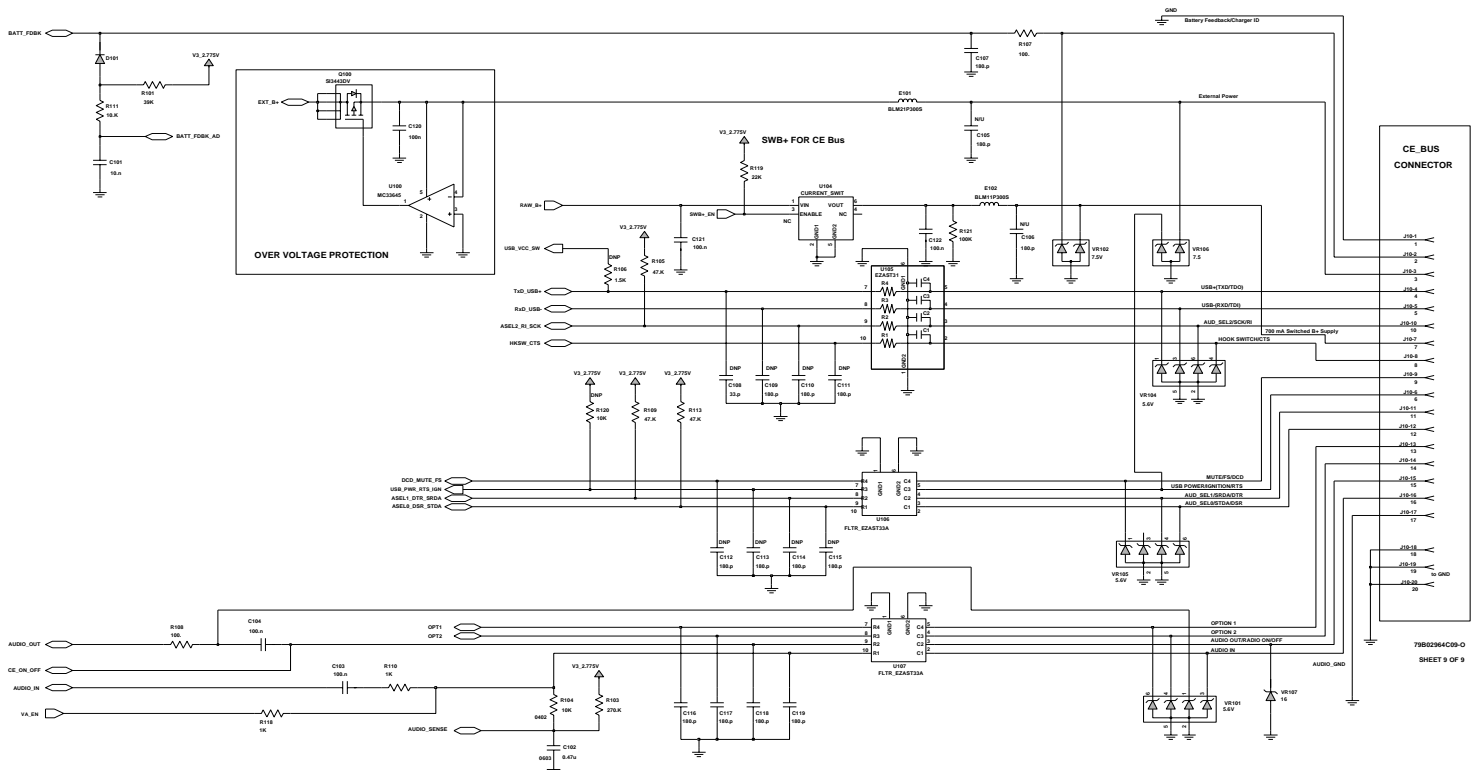



## MTH500 (FLF9011A) Component Parts (for reference only)

When ordering component parts, the part number should be included. If the correct numbers cannot be located, call Motorola Parts Identification.

CAPACITORS														
Ref #	Part #	Description	Ref #	Part #	Description	Ref #	Part #	Description	Ref #	Part #	Description	Ref #	Part #	Description
C001	2113743p01	180pF	C401-402	2113743M24	100nF	C526-527	2113743n26	10pF	C608	2113743M24	100nF	C701-703	2360567A06	100µF
C002	2113740F39	33pF	C403	2113743L41	10nF	C528	2113743n24	8.2pF	C609	2113928C04	4.7µF	C704	2311049G32	10µF
C003	2113740F39	33pF	C404-409	2113743M24	100nF	C530	2113743L41	10nF	C610-611	2113928k09	10µF	C800	2113740F49	82pF
C004	2113743p01	180pF	C410	2113743L41	10nF	C531	2113741F41	4.7nF	C612-614	2113928C04	4.7µF	C802	2113743L03	270pF
C005	2113743p01	180pF	C412	2113743M24	100nF	C532	2113743n22	6.8pF	C615	2113928D08	10µF	C805	2113743L03	270pF
C006	2113743p01	180pF	C413-414	2113740F57	180pF	C533	2113928U08	10nF	C616	2311049A72	Tant. 10µF	C808	2113740F57	180pF
C007	2113743p01	180pF	C415-416	2311049A59	Tant. 10µF	C534	2113743L41	10nF	C617-620	2113743p01	180pF	C809	2113743L03	270pF
C008	2113743p01	180pF	C417-419	2113743L41	10nF	C535	2113928n01	100nF	C621	2113743L17	1nF	C811-812	2113743L03	270pF
C009	2113743p01	180pF	C420-421	2113928P04	1µF	C536	2113743n34	22pF	C622	2113743L07	390pF	C814-816	2113743L03	270pF
C010	2113743p01	180pF	C422	2113741F49	10nF	C539	2113743Q08	1.8pF	C623	2311049C16	Tant. 68µF	C817	2113740F57	180pF
C011	2113743p01	180pF	C423	2113741F45	6.8nF	C542	2113743L29	3.3nF	C624	2311049C15	Tant. 33µF	C819-821	2113743L03	270pF
C012	2113743p01	180pF	C424	2113743M24	100nF	C545	2113743n19	5.1pF	C625	2311049C14	Tant 100µF	C822-823	2113741F25	1nF
C013	2113743p01	180pF	C425-426	2113743L41	10nF	C546	2113743Q07	1.5pF	C626-627	2113928C04	4.7µF	C824	2113743L03	270pF
C014	2113743p01	180pF	C427-429	2113743M24	100nF	C547	2113928n01	100nF	C628	2113928P04	1µF	C827-830	2113743L03	270pF
C015	2113743p01	180pF	C430	2113928n01	100nF	C549	2113928n01	100nF	C629	2113928C04	4.7µF	C831	2113743N69	1.8pF
C016	2113743p01	180pF	C500	2113743L03	270pF	C550-552	2113743117	1nF	C630-635	2113928P04	1µF	C832	2113743N46	68pF
C017	2113743p01	180pF	C501-502	2113928n01	100nF	C553	2113928N01	100nF	C636	2113743L07	390pF	C833	2113743L09	470pF
C031	2113743p01	180pF	C503	2113743L41	10nF	C554	2113743E12	47nF	C637-638	2113743N32	18pF	C834	2113743L03	270pF
C032	2113743p01	180pF	C504	2113928n01	100nF	C555	2113928n01	100nF	C639-643	2113743M24	100nF	C835	2113743N32	18pF
C037	2113743p01	180pF	C505	2113743L17	1nF	C557	2113743E03	15nF	C644	2113928n01	100nF	C837	2113740F39	33pF
C038	2113743N38	33pF	C507	2113743L17	1nF	C560-561	2311049A59	Tant. 10µF	C646-648	2113740F57	180pF	C838	2113743N18	4.7pF
C049	2113743N38	33pF	C508	2113928n01	100nF	C572-573	2113928n01	100nF	C649	2113928C04	4.7µF	C839	2113740F47	68pF
C101	2113743L41	10nF	C510	2113743L03	270pF	C574	2113743L03	270pF	C650	2113743M24	100nF	C840	2113740F30	18pF
C102	2113928A02	0.47µF	C512	2113743L03	270pF	C576	2113743L03	270pF	C651	2113740F57	180pF	C841	2113740F47	68pF
C103-104	2113928n01	100nF	C513	2113743L17	1nF	C577	2113743L41	10nF	C652	2311049G32	Tant. 10µF	C842	2113743N34	22pF
C107	2113743p01	180pF	C514	2113743L03	270pF	C580	2113743117	1nF	C653	2311049C18	4.7µF	C843	2113743N30	15pF
C116-119	2113743p01	180pF	C515-516	2113928n01	100nF	C590	2113743L03	270pF	C654	2113928C04	4.7µF	C844-845	2113743N28	12pF
C120-121	2113743M24	100nF	C518-519	2113928n01	100nF	C600	2113743M24	100nF	C655	2113743L41	10nF	C846	2113743N26	10pF
C122	2113928s04	100nF	C521	2113743n15	3.6pF	C601	2113928D08	10µF	C657-661	2113928C04	4.7µF	C847	2113743N24	8.2pF
C200	2113743L03	270pF	C522	2113743N50	100pF	C602	2113743L41	10nF	C662	2113928S02	0.047µF	C848	2113743N25	9.1pF
C203	2113743L03	270pF	C524	2113743Q08	1.8pF	C603	2113743117	1nF	C663	2113743L29	3.3nF			
C205	2113743L03	270pF	C525	2113743n28	12pF	C604-607	2113928n01	100nF	C664	2113743L07	390pF			

SCHEMATIC DIAGRAMS - MTH500 (FLF9011A) Component Parts (for reference only)

CAPACITORS														
Ref #	Part #	Description	Ref #	Part #	Description	Ref #	Part #	Description	Ref #	Part #	Description	Ref #	Part #	Description
C849	2113743N11	2.4pF	C909-910	2113743N50	100pF	C984	2113743L37	470pF				E007	2409134j04	blm11b601s
C850	2113743N17	4.3pF	C915	2113743N50	100pF	C1004	2113928n01	100nF				E008	9108445S04	fm60r
C851	2113743N13	3pF	C916	2113743L17	1nF	C1009	2113743L37	6.8pF				E009	9108445S04	fm60r
C852	2113740F21	1pF	C919	2113743n30	15pF	C1010	2113743N22	8.2pF				E010	7686949j02	blm10b601sdp
C853-857	2113743L17	1nF	C920	2113740F25	8.2pF	C1011	2113740F17	3.9pF				E101	2480675U01	idctr
C859	2113743L07	390pF	C921-922	2113740F27	10pF	C1012	2113740L05	3pF				E102	7686949j08	idctr
C860	0804533C48	22nF	C927	2113740F31	15pF	C1014	2113743L03	270pF				E201	2480675U01	idctr
C861-862	2113743E05	18nF	C929	2113740F20	5.1pF	C1015	2113743N20	5.6pF				E203	2480675U01	idctr
C863-864	2113741F45	6.8nF	C930	2113743N50	100pF	C1016	2113743N40	39pF				E400-401	2480067M02	blm21a121s
C865	2113743L17	1nF	C931	2113740F20	5.1pF	C1020	2113928n01	100nF				E500-501	7686949j02	blm10b601sdp
C866	2113743L03	270pF	C932	2113740F31	15pF	C1021	2113743L03	270pF				E600	2480675U01	idctr
C867	2113740F35	2.7nF	C933	2113743n20	5.6pF	C1022	2113928P04	1µF				E601-604	2409134J04	blm11b601s
C869	2113928N01	100nF	C937	2104263L01	100nF	C1023-24	2113743K15	100nF				E800	7686949j02	blm10b601sdp
C873	2113743L17	1nF	C938	2113743n17	4.3pF	C1028	2186113u01	56pF				E801	9108445S04	fm60r
C874-875	2113928n01	100nF	C939	2113743N15	3.6pF	C1029	2113740F30	13pF				E803	2409134J04	blm11b601s
C877-878	2113743cL37	6800pF	C940	2113740L01	2pF	C1030	2113740F24	7.5pF				E806	2409134J04	blm11b601s
C879	2113741F49	10nF	C942	2113740F25	8.2pF	C1031-1032	2113743L03	270pF				E807	7686949j02	blm10b601sdp
C880	2113741F45	6.8nF	C946	2113743N50	100pF	C1045	2113743L07	390pF	CR600-603	4813833a19	mbrm120L	E808-809	2409134j04	blm11b601s
C881-882	2113741F41	4.7nF	C948	2113743L37	6.8nF	C1046	2113928W09	47µF	D001	4808032h08	1ss355	E810	7686949j02	blm10b601sdp
C883	2113928n01	100nF	C951	2113743n28	12pF	C1048	2113743L03	270pF	D101	4809948D42	1ss367	E901	7686949j02	blm10b601sdp
C886	2113740F41	38pF	C953	2113743L17	1nF	C1050	2113743L03	270pF	D500	4808115L17	tekelec			
C887	2113743N46	68pF	C954	2113743L03	270pF				D601	4809948D42	1ss367	FUSES		
C888	2113743L03	270pF	C955	2113743L03	270pF				D800	4804135k05	1sv231	Ref #	Part #	Description
C890	2113743N40	39pF	C957	2113743L33	4.7nF				D801	4885908A02	ma4p789	F600	6586221j04	2.5A 16V
C891	2113743L03	270pF	C958	2104263L01	100nF				D902	4809877c13	1sv305			
C894	2113740F51	100pF	C959	2113743L17	1nF				D907	4805656W28	BBY5802W			
C895	2113743L29	3.3nF	C960	2113740F24	7.5pF				BEADS					
C897	2113743N38	33pF	C961	2113743L48	22nF				Ref #	Part #	Description			
C898-899	2113743L03	270pF	C962	2113743N33	20pF				E001	2409134j04	blm11b601s			
C901-902	2113928n01	100nF	C966	2113743L17	1nF				E002	7686949j02	blm10b601sdp			
C903	0804533C50	33nF	C967	2113743L03	270pF				E003	7686949j02	blm10b601sdp			
C904	2113743L03	270pF	C968	2113743L17	1nF				E004	7686949j02	blm10b601sdp			
C905-906	2113743N50	100pF	C970-971	2113743L17	1nF				E005	7686949j02	blm10b601sdp			
									E006	7686949j02	blm10b601sdp			

FILTERS									TRANSISTORS					
Ref #	Part #	Description	Ref #	Part #	Description	Ref #	Part #	Description	Ref #	Part #	Description	Ref #	Part #	Description
FL500	9180310L24	390mhz	L530	2409154M21	47n	L916	2413926g16	56n	Q002	4809579E50	si1905dl	R011	0662057N11	33K
FL501	9186216J06	380mhz	L600	2408603y01	4.7uh	L917	2413926g05	6.8n	Q100	4809579E29	si3443	R012	0662057M24	1000K
FL502	9185898A02	109.65mhz	L601	2486085A02	15u	L918-919	7686949j02	blm10b601sdp	Q500	4805723X03	umd3n	R013	0662057M90	res_4_7K
FL800	9180310L23	390mhz	L602	2486085A05	47uh	L920	2460591C23	13.85n	Q504	4805723X03	umd3n	R014	0662057M98	res_10K
FL801	S804901K15	380mhz	L800	2409154M23	68n	L921	2486616u01	5.6n	Q600	4885140c01	fd86875	R015	0662057m34	res_22
			L801	2409377M10	33n	L922	7686949j02	blm10b601sdp	Q602	4805128M27	bsr33	R016	0662057m34	res_22
CONNECTORS			L803	2413926g19	100n	L923	2485930822	2.8n	Q800	4805723X03	umd3n	R025	0662057M74	res_1K
Ref #	Part #	Description	L805	2413926g19	100n	L926	2409154M17	22n	Q801	4805793y01	ne68519	R101	0662057V17	res_39K
J10	0987636k05	conn_ce	L806	2413926g17	68n	L930	2486170u01	390n	Q804	4805723X03	umd3n	R103	0662057n33	res_270K
J700	0987984k02	conn_va	L807	2409154M20	39n	L931	2486185u01	1u	Q805	4805921H11	21H11	R104	0662057M98	res_10K
			L808	2409154M17	22n	L932	2409154M20	39n	Q806-807	4805723X03	umd3n	R105	0662057n15	res_47K
			L809-810	2409154M14	12n				Q808	4809579E41	nc38018	R107-108	0662057m50	res_100
			L811-812	2413926m12	8.2n	CONTACTS			Q900	4805723X02	umt1	R109	0662057n15	res_47K
			L813	2413926g11	22n	Ref #	Part #	Description	Q903-905	4805793y01	ne68519	R110	0662057M74	res_1K
INDUCTORS			L815	2409154M22	56n	M001	398638901	contact_Spkr	Q907	4805723X03	umd3n	R111	0662057M98	res_10K
Ref #	Part #	Description	L816	2409154M23	68n	M002	398638901	contact_Spkr	Q910	4805723X03	umd3n	R113	0662057n15	res_47K
L500	2487685L08	22n	L817	2409377M06	15n	M005	398653501	contact_Vibrator						
L501	2462587V42	470n	L818	2487685L08	22n	M006	398653501	contact_Vibrator						
L504	2462587V42	470n	L819	2409377M19	128n	M500	398691601	contact_Ant_Hot	RESISTORS					
L505	2413926G17	68n	L890	2460591C23	13.85n	M501	398691701	contact_Ant_Gnd	Ref #	Part #	Description			
L508	2413926G16	56n	L903	2486170u01	390n	P1	0989368K01	Connector J	R001	0662057n07	res_22K			
L512-513	2413926G08	12n	L905	2409377M12	47n	P15	2886925J04	Connector P	R003	0662057n01	res_12K			
L518	2409154M19	33n	L906	2409154M19	33n				R004	0662057M81	res_2k			
L519-520	2462587V38	220n	L907	2409154M13	10n				R008	0662057M40	res_39			
L525	2409154M17	22n	L912-913	2486170u01	390n				R010	0662057M01	res_0			

SCHEMATIC DIAGRAMS - MTH500 (FLF9011A) Component Parts (for reference only)

RESISTORS (Continued)												MISCELLANEOUS		
Ref #	Part #	Description	Ref #	Part #	Description	Ref #	Part #	Description	Ref #	Part #	Description	Ref #	Part #	Description
R118	0662057M74	res_1K	R640	0662057M74	res_1K	R835	0662057M67	res_510	R960	0662057M74	res_1K	U100	5109731 C32	MC33645
R119	0662057N07	res_22K	R642	0662057N13	res_39K	R836	0662057M61	res_300	R961	0662057M62	res_330	U104	5109817 F45	current switch
R121	0662057N23	res_100K	R643	0662057M78	res_1.5K	R838	0662057m54	res_150	R962-963	0662057M90	res_4.7K	U105	9185759B02	ezast31
R401	0662057M01	res_0	R645-646	0662057V21	res_56K	R899	0662057N23	res_100K	R964	0662057M81	res_2K	U106	9186133U02	FLTR_ezast33a
R405	0662057N07	res_22K	R647	0662057M01	res_0	R901	0662057n15	res_47K	R965	0662057M60	res_270	U107	9186133U02	FLTR_ezast33a
R407	0662057A17	res_47	R649	0662057M50	res_100	R906	0662057M90	res_4.7K	R966	0662057M40	res_39	U401	5185130C40	redcap 30c40
R417	0662057M94	res_6.8K	R650	0662057N13	res_39K	R907-908	0662057M32	res_18	R967	0662057M34	res_22	U402	5189509A43	SRAM 512k
R500	0662057M74	res_1K	R651	0662057M74	res_1K	R909	0662057M99	res_11K	RF500	0686931j01	therm_47K	U403	5199420A01	flash -2m
R504	0662057M38	res_33	R800	0662057M61	res_300	R911	0662057M82	res_2.2K	RF800	0686931j01	therm_47K	U405	2480067m02	blm21a121s
R512	0662057U94	res_5.1	R801	0662057m90	res_4.7K	R913	0662057M72	res_820				U500	5185368c01	rT261
R514-515	0662057N23	res_100K	R802-804	0662057m82	res_2.2K	R914	0662057M87	res_3.6K				U503	5185127c02	wpic27c02
			R805	0662057M68	res_560	R915	0662057M90	res_4.7K				U504	5108428s91	mixer
R519	0662057M01	res_0	R806	0662057m76	res_1.2K	R916	0662057m82	res_2.2K				U600	5109879e83	gcap-3
R520-521	0662057N23	res_100K	R807	0662057m67	res_510	R917	0662057M47	res_75				U601	5104667m01	lp2980
R580	0662057M58	res_220	R808	0662057m61	res_300	R918	0662057m56	res_180				U800	5109944C20	linear mixer RF
R600	0680195M64	res_0.24	R809	0662057m54	res_150	R919	0662057M67	res_510				U801	5880334L02	i/q splitter
R601	0662057n11	res_33K	R810	0662057M50	res_100	R921	0662057m60	res_270	SHIELDS			U802	4808115L16	pin diode
R602-604	0662057v24	res_75K	R812	0662057m60	res_270	R922	0662057m64	res_390	Ref #	Part #	Description	U803	5108428S43	Lnodet
R605	0662057V21	res_56K	R814	0662057m43	res_51	R923-924	0662057m46	res_68	SH001	2686672t01	shield	U804	9186395J02	380MHz-BW
R606-607	0662057m82	res_2.2K	R815	0662057M54	res_150	R925	0662057m38	res_33	SH003	2686661t01	shield	U806	5880334L06	coupler
R608	0662057N07	res_2.2K	R816-817	0662057m43	res_51	R927	0662057m34	res_22	SH004	2686671t01	shield	U808	5186226j12	lmc2332
R609	0662057m82	res_2.2K	R818	0662057M54	res_150	R931	0662057M96	res_8.2K	SH005	2686663t01	shield	U809	5108683Y04	RF2175
R610	0662057N07	res_22K	R819	0662057M32	res_18	R932	0662057M77	res_1.3K	SH007	2686670t01	shield	VR003	4885849B01	49b01
R611	0662057m93	res_6.2K	R820	0662057M24	res_8.2	R934	0662057M74	res_1K	SH500	2686831t01	shield	VR101	4885656W08	mmqa5v6t1
R612	0662057n11	res_33K	R821-824	0662057M32	res_18	R936	0662057M50	res_100	SH800	2686655t01	shield	VR102	4885656B01	49b01
R613-614	0662057m74	res_1K	R825	0662057M40	res_39	R937	0662057m43	res_51	SH802	2686830t01	shield	VR104	4805656W08	MMQA5V6T1
R615	0662057V24	res_75K	R826	0662057M43	res_51	R939	0662057M50	res_100	SH900	2686658t01	shield	VR105	4805656W08	MMQA5V6T1
R617	0662057m82	res_2.2K	R827	0662057MV70	res_301	R943	0662057M68	res_560	SH901	2686659t01	shield	VR106	4885849B01	49B01
R620-622	0662057n13	res_39K	R828	0662057V69	res_215	R944	0662057M34	res_22				V107	4813830C29	mmsz5246b1
R623-625	0662057M01	res_0	R829	0662057M96	res_8.2K	R950	0662057M67	res_510				VR601	4813830A19	mmbz5236b
R629	0662057m93	res_6.2K	R832	0662057M50	res_100	R953	0662057M50	res_100				V501	5102845C20	txco 16.8 mhz
R630	0662057m82	res_2.2K	R833	0662057M32	res_18	R954	0662057M57	res_200				Y600	4809951L05	xial 32.768 khz
R631-632	0662057M50	res_100	R834	0662057M61	res_300							Y901	4804122K12	resonator

MTH500 Flex CD

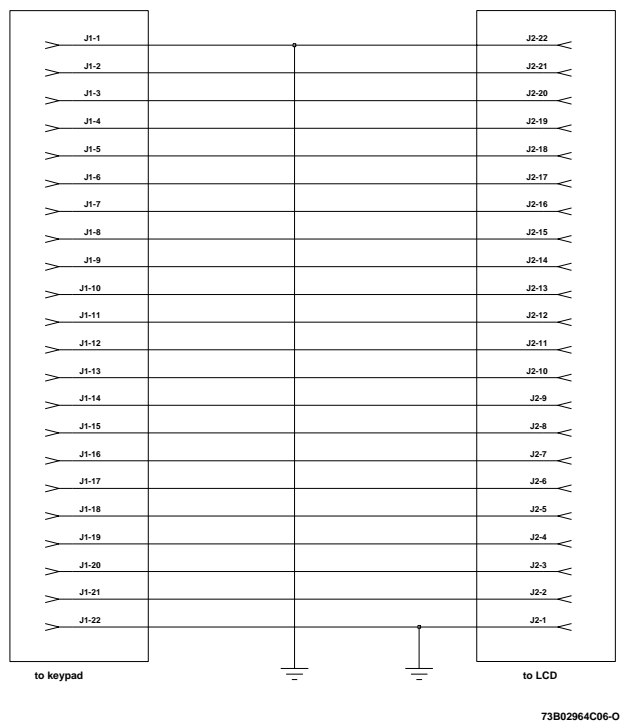

**This page left blank intentionally**



# Appendix 1 Replacement Parts and Kits

---

---

## REPLACEMENT PARTS AND KITS

Damaged parts should be replaced with identical replacement parts.

### Replacement Parts

For complete information on ordering required parts and kits, contact your local customer service representative.

### Level 3 Maintenance

## EMEA Region

EMEA Radio Support Depots are level 3 service partners. The depots are capable of performing repairs down to component level where retuning is required. Contact your local CGISS office for information.

Motorola European Radio Support Centre ERSC Phone: +49 6128 702618  
Heinrich Hertz Strasse 1  
D-65232 Taunusstein  
Germany

ERSC Customer Information Desk available through the following service number:

Austria:	06 60 75 41	Italy:	16 78 77 387
Belgium:	08 00 72 471	Luxemburg:	08 00 23 27
Denmark:	80 01 55 72	Netherlands:	60 22 45 13
Finland:	08 00 11 49 10	Norway:	80 01 11 15
France:	05 90 30 90	Portugal:	05 05 49 35
Germany:	01 30 18 75 24	Spain:	90 09 84 902
Greece:	00 80 04 91 29 020	Sweden:	02 07 94 307
UK:	08 00 96 90 95	Switzerland:	1 55 30 82
Ireland:	18 00 55 50 21	Iceland:	80 08 147
or dial	+49 6128 70 2618		

Please use these numbers for repair enquires only.

## Latin America Region

Latin America Radio Support Centers

The Customer Support is available through the following service centers:

**Warranty and Repairs:**

Motorola De Colombia Service Center

Carrera 7 No. 71-52

Torre B piso 13

Oficina 1301

Bogota- Colombia

(571) 376-6990

**Motorola De Mexico Service Center**

Bosques de Alisos #125

Col. Bosques de las Lomas

CP 05120 Mexico DF

5252576700

**Piece Parts:**

To order parts in Latin America and the Carribean:

7:00 A.M. to 7:00 P.M. (Central Standard Time)

Monday through Friday (Chicago, USA)

1-847-538-8023

**Technical Support:**

<https://businessonline.motorola.com>, go to Contact Us to request technical support

**Motorola Parts (Accessories and Aftermarket Division AAD):**

Attention: Order Processing

1313 E. Algonquin Road

Schaumburg, IL. 60196

**Parts Identification:**

1-847-538-0021 (Voice)

1-847-538-8194 (Fax)

Some replacement parts, spare parts, and/or product information can be ordered directly. If a complete Motorola part number is assigned to the part, it is available from Motorola Radio After market and Accessory Division (AAD). If no part number is assigned, the part is not normally available from Motorola. If the part number is appended with an asterisk, the part is serviceable by Motorola Depot only. If a parts list is not included, this generally means that no user-serviceable parts are available for that kit or assembly.



---

## Radio Replacement Parts List

Part/Kit Number	MTH500 Model Description
0186163T07 0186163T08	Front Housing Assembly (Black) Front Housing Assembly (Blue)
0186630T01	Keypad Assembly
0186396T04 0186396T05	Back Housing Assembly (Black) Back Housing Assembly (Blue)
8586381J03	Antenna 380-400 MHz (R1)
0186613T01 0186613T02	Standard Battery Door Assembly (Black) Standard Battery Door Assembly (Blue)
0186239T01 0186239T02	Extended Battery Door Assembly (Black) Extended Battery Door Assembly (Blue)
7287702M01	LCD Module
FCN9090A	Keypad Kit
FCN9797A	LCD Kit
(See Service Replacement Kit Matrix below)	Main Board (R1)

## Accessories Replacement Parts List

Kit Number	MTH500 Model Description
<b>Batteries</b>	
FTN6030A	Extended battery, 1100mAh, LiIon, Black (with battery door)
FTN6037A	Extended battery, 1100mAh, LiIon, Blue (with battery door)
FTN6031A	Standard battery, 800mAh, LiIon, Black (with battery door)
FTN6038A	Standard battery, 800mAh, LiIon, Blue (with battery door)
<b>Chargers</b>	
FLN9468A	Dual Pocket Desktop Charger
SPN4716B	Travel charger
SYN7455A	Plug Adapter UK for travel Charger
SYN7456A	Plug Adapter EU for travel Charger
FLN9469A	Vehicular battery charger
<b>Vehicular Adapters</b>	
FLN2850A	Car Kit
FLN9569A	Stand alone car cradle
<b>Audio accessories</b>	
WADN4184A	Headset with Boom mic and in line PTT
FLN9470A	Headset with Boom mic (On Hold)
FLN9568A	PHF
<b>Carrying Accessories</b>	
FLN9476A	Soft leather carry case
FHN6246A	Belt clip
<b>Others</b>	
FKN4897A	Data cable

## Recommended Programming Equipment

Name	Part Number
MTH500 CPS	PMVN4065B
Data Cable	FKN4897A

## Service Replacement Kit Matrix (1)

Sales Model Description	Service Tanapa	Description
MTH500 Black 380-400 MHz PT811F	FUF1208AS	MTH500 Black S/T R1 CLEAR
	FUF1210AS	MTH500 Black S/T R1 TEA1
	FUF1211AS	MTH500 Black S/T R1 TEA2
MTH500 Blue 380-400 MHz PT811F	FUF1209AS	MTH500 Blue S/T R1 CLEAR
	FUF1212AS	MTH500 Blue S/T R1 TEA1
	FUF1213AS	MTH500 Blue S/T R1 TEA2

**Note:** All models listed in the Service Tanapa Column are not field replaceable for Latin America









## Appendix 2 Test Equipment, Service Aids & Tools

---

---

The table below lists the special test equipment required for servicing MTH500 radios.

Name	Part Number
Anritsu Digital Signal Generator	MG3660A
Power Meter	HP437B
Power Supply	HP6032A
Universal Multimeter	HP3457A
RF Probe	HP85024A
Spectrum Analyzer	HP8560E
R&S Audio Analyzer	UPL16
Data Cable	FKN4897
Flash/Data programming cable	FLN9636
IFR System	2968

**THIS PAGE INTENTIONALLY LEFT BLANK**





# Appendix 3 Self Check Error/Fail Code Tables

---

## General

This appendix describes the possible self check error codes for the MTH500 Portable Radios.

---

## Self Check Error Codes

Table 1. is the possible self check error (non fatal) codes for the MTH500 Portable Radios. No corrective action is required.

**Table 1. Self Check Error (Non-Fatal) Codes**

Message	Cause
Error00001	A non-fatal error was logged during operation
Error00002	Codeplug error log validity error

Table 2. is the possible self check fail (fatal) codes for the MTH500 Portable Radios. The radio is inoperable, the user should return the radio to Depot.

**Table 2. Self Check Fail (Fatal) Codes**

Message	Cause
Fail00100	Old CodePlug Version failure
Fail00200	New CodePlug Version failure
Fail00400	CodePlug Model failure
Fail00800	Codeplug validity error
Fail00801	CP - Unknown block
Fail00802	CP - Unknown eld
Fail00803	CP - Unknown ag

Message	Cause
Fail00804	CP - Unknown format
Fail00805	CP - Invalid pointer
Fail00806	CP - Invalid path
Fail00807	CP - Invalid handler
Fail00808	CP - Invalid length
Fail00809	CP - Invalid index
Fail0080A	CP - Invalid offset
Fail0080B	CP - Invalid header pointer
Fail0080C	CP - Invalid block header
Fail0080D	CP - Initialization failed
Fail0080E	CP - Recovery failed
Fail0080F	CP - Write failure
Fail00810	CP - Corrupted block
Fail00811	CP - Corrupted codeplug
Fail00812	CP - Radio Operation System error
Fail00813	CP - Lower layer error
Fail00814	CP - Too many arguments
Fail00815	CP - Log overflow
Fail00816	CP - Invalid check sum
Fail00817	CP - Not initialized
Fail00818	CP - Ambiguous code
Fail00819	CP - Invalid start entry
Fail0081A	CP - Duplicate data
Fail0081B	CP - Invalid version number
Fail01000	Flash checksum error
Fail02000	A fatal error was logged during operation
Fail10000	Handset communication error
FailF4000	Ergo pre-selftest codeplug error
FailF8000	Ergo pre-selftest invalid device error



## Appendix 4 Glossary

---

---

<b>μC</b>	Microcontroller
<b>ABACUS</b>	Analog to digital converter for a radio receiver.
<b>A/D</b>	Analog to Digital
<b>A/D Converter</b>	A device that converts an instantaneous dc voltage level to a corresponding digital value. Also known as CODEC.
<b>ACELP</b>	Algebraic Code Excited Linear Prediction
<b>AGC</b>	Automatic Gain Control
<b>BDM</b>	Background Debug Mode
<b>CPS</b>	Customer Programming Software
<b>D/A</b>	Digital to Analog converter
<b>D/A Converter</b>	A device that converts a digital value to a corresponding dc voltage value.
<b>DQPSK</b>	Differential Quadrature Phase Shift Keying. A sub-class of the QPSK methods of transmitting data. Rather than using the absolute value of phase (as in QPSK), only the difference between the current value of phase and the previous value of phase are used. By using phase differences, the implementation is simpler (since an absolute reference source is not required).
<b>DSI</b>	Data Serial Input
<b>DSO</b>	Data Serial Output
<b>DTMF</b>	Dual Tone Multi-Frequency
<b>DSP</b>	Digital Signal Processor; microcontroller specifically tailored for signal processing computations.
<b>EEPROM</b>	Electrically Erasable Programmable Read Only Memory. Integrated circuit used to store data, which can be erased by electrical methods.
<b>GCAP</b>	Global Control Audio Power
<b>IC</b>	Integrated Circuit
<b>IF</b>	Intermediate Frequency

<b>IMIC</b>	Integrated Memory Interface
<b>I &amp; Q</b>	In-phase & Quadrature
<b>LCD</b>	Liquid Crystal Device/Display
<b>LED</b>	Light Emitting Diode
<b>LO</b>	Local Oscillator
<b>LPF</b>	Low-Pass Filter
<b>OOIC</b>	On-Off Interface Circuit
<b>PCB</b>	Printed Circuit Board
<b>PLL</b>	Phase Locked Loop. A circuit in which an oscillator is kept in phase with a reference, usually after passing through a reference divider.
<b>POR</b>	Power Reset
<b>PTT</b>	Push-To-Talk
<b>RESET</b>	Reset line; an input to the microcontroller that restarts execution.
<b>RF PA</b>	Radio Frequency Power Amplifier
<b>RTS</b>	Request-To-Send
<b>SRAM</b>	Static-RAM chip used for volatile, program/data memory.
<b>SSI</b>	Synchronous Serial Interface
<b>RF</b>	Radio Frequency
<b>STN</b>	Super Twisted Nematic
<b>TDMA</b>	Time Division Multiple Access
<b>TDS</b>	TETRA Diagnostics Software
<b>TOT</b>	Time-Out Timer; a timer that limits the length of a transmission.
<b>TranLin IC</b>	Transmit Linear IC
<b>UART</b>	Universal Asynchronous Receiver Transmitter
<b>VCO</b>	Voltage-Controlled Oscillator; an oscillator whereby the frequency of oscillation can be varied by changing a control voltage.
<b>VVA</b>	Voltage Variable Attenuator
<b>WPIC</b>	World Phone Integrated Circuit