

Owner's Manual

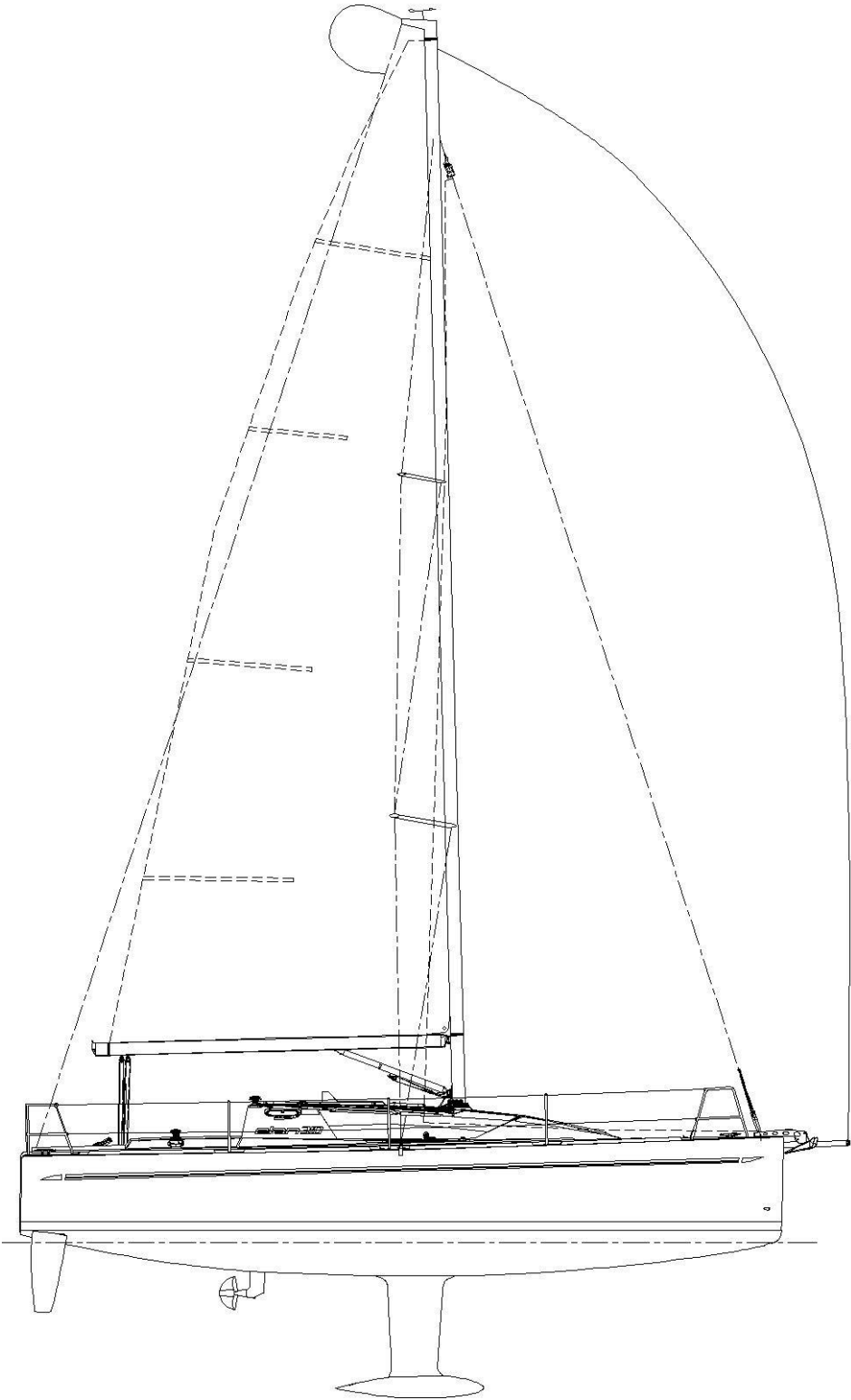

elan 310

Dear sailor,

Setting sail towards distant shores and pristine ocean sunsets has always been a little boys dream. Sailing is an act of nature; it is one of the last means to freely live your passion. We filled this Elan sailing yacht with passion - passion of design, woodwork, traditional craftsmanship and beauty.

We gave her passion - all you need is to give her love...

Your ELAN Marine Team

ELAN MARINE d.o.o.
Begunje 1
4275 Begunje na Gorenjskem
Slovenia
Tel: +386 45 351 370
Fax: +386 45 351 360
e-mail: elan.marine@elan.si
http: www.elan-yachts.com

OWNER MANUAL PREFACE

Dear ELAN owner,

We are proud you have chosen an ELAN sailing yacht and we would like to thank you for your trust!

We wish you fair winds on the seas wherever you go....!

Your sailing yacht represents an investment for you, and we therefore hope that you will follow our advice in order to protect its value over time.

To become fully acquainted with your ELAN sailing yacht, we suggest dedicating adequate time to carefully reading the owner's manual and its supplements.

In order to obtain optimum performance from your ELAN sailing yacht and to make the best use of its advanced performance features, as well as for your personal safety, you should carefully follow the instructions and standards set forth in this manual.

The manual describes the full equipment provided at the moment of printing. ELAN Marine reserves the right to modify said equipment without prior notification and without the obligation to upgrade products already built and/or sold.

Features indicated with (*) are available as optional equipment.

The ELAN Marine boatyard works unceasingly to enhance all our sailboat models. So please bear with us, and understand if we must reserve the right to make modifications in manufacture, shape, equipment and technology without giving prior notification.

This manual and the data, illustrations and descriptions it contains do not constitute grounds for making claims against the manufacturer.

Elan Marine d.o.o. reserves the right to modify specifications without prior notice or obligation.

FOREWORD

Even if everything has been planned and designed for the safety of the sailing yacht and its users, boating is highly dependant on the weather conditions, the sea conditions, the experience and physical shape of the crew, etc. and one can never ensure full safety.

This manual has been compiled to help you operate your sailing yacht with safety and pleasure. It contains details of the sailing yacht; the equipment supplied or fitted, its systems and information on its operation and maintenance. Please read it carefully, and familiarise yourself with the sailing yacht before using it.

If this is your first sailing yacht or you are changing to a type of sailing yacht you are not familiar with, for your own comfort and safety, please ensure that you obtain handling and operating experience before assuming command of the sailing yacht. Your dealer, national sailing federation or yacht club will be pleased to advise you about local sea schools or competent instructors.

PLEASE KEEP THIS MANUAL IN A DRY AND SECURE PLACE AND HAND IT OVER TO THE NEW OWNER WHEN YOU SELL THIS SAILING YACHT.

CONTENTS

1. FOREWORD	4
1.1. DECLARATION OF CONFORMITY	7
2. WARRANTY CONDITIONS OF YOUR ELAN	9
3. IMPORTANT INFORMATION	12
3.1. DEGREES OF DANGER	12
3.2. LABELS ON BOARD	12
3.3. LIABILITY OF THE OWNER/OPERATOR	13
3.4. FIRE PROTECTION AND ESCAPE PLAN	13
3.5. PRE-DEPARTURE CHECK LIST	14
3.6. WATER INTAKE DURING SAILING AND STRANDING	14
3.7. CLOSING UP YOUR CRAFT AFTER SAILING CHECK LIST	15
3.8. CRAFT IDENTIFICATION, BUILDER'S PLATE	15
4. TECHNICAL SPECIFICATIONS	16
4.1. TECHNICAL DATA	16
4.2. DEFINITION OF DESIGN	17
4.3. MAXIMUM TOTAL LOAD	17
5. GENERAL ARRANGEMENT	17
5.1. DECK LAYOUT	17
5.2. INTERIOR LAYOUT	18
5.3. PROFILE	19
6. PROPULSION SYSTEM	20
6.1. SAILS AND MAST	20
6.2. ENGINE SYSTEM	20
6.2.1. ENGINE OPERATION	21
6.2.2. ENGINE AND PROPELLER INSTALLATION	22
6.2.3. FUEL SYSTEM	23
7. SYSTEMS AND CIRCUITS	24
7.1. POSITION OF SEACOCKS AND THROUGH-HULL FITTINGS	24
7.2. WATER SYSTEMS	25
7.2.1. FRESH WATER SYSTEM	25
7.2.2. HOT WATER SYSTEM	26
7.3. SEA AND WASTE WATER SYSTEM	27
7.4. BILGE WATER SYSTEM	28
7.5. GAS SYSTEM	28
7.6. ELECTRICAL SYSTEMS	31
7.6.1. 12 V SYSTEM	31
7.6.2. 230 V SYSTEM	32

7.7. RUDDER AND STEERING SYSTEM	33
8. GARBAGE DISCHARGE	35
9. MAINTENANCE	36
9.1. HAULAGE	36
9.2. UNDERWATER STRUCTURE	36
9.2.1. HULL	36
9.2.2. PROTECTION OF TERMINALS	37
9.3. HULL AND DECK	37
9.3.1. CLEANING	37
9.3.2. STAINS, SCRATCHES AND ABRASION	38
9.4. MAST, SAILS AND RIGGING	38
9.5. DECK EQUIPMENT	39
9.5.1. LIFELINES, PULPITS AND STANCHIONS	39
9.5.2. WINCHES AND BLOCKS	39
9.5.3. ANCHOR WINDLASS	39
9.5.4. TEAK	39
9.5.5. PLEXIGLAS, PORTLIGHTS AND HATCHES	40
9.6. INTERIOR	40
9.6.1. INTERIOR WOOD SURFACES	40
9.6.2. CUSHIONS AND CURTAINS	40
9.6.3. REFRIGERATOR	40
9.6.4. COOKER	40
9.6.5. SINK	41
9.6.6. BILGE STRAINERS AND PUMPS	41
9.6.7. FUEL AND WATER TANKS	41
10. WINTERISATION	41
10.1. BLOCKING THE HULL	41
10.2. COOKER	41
10.3. ELECTRICAL SYSTEM	42
10.4. WATER SYSTEMS	42
10.5. SEACOCKS	42
10.6. FUEL TANK	42
10.7. ENGINE	42
10.8. SAILS	42
10.9. COVERING	42
10.10. CUSHIONS	43
10.11. INTERIOR	43
11. PRODUCT END OF LIFE DISPOSAL	43
12. ANNEX	44
12.1. WEBASTO HEATING SYSTEM	47
12.2. ELECTRICAL SYSTEMS DRAWINGS	48

Declaration of Conformity of Recreational Craft with the Design, Construction and Noise Emission requirements of Directive 94/25/EC as amended by Directive 2003/44/EC
(To be completed by boat builder)

Name of craft manufacturer: ELAN Marine d.o.o.

Address : Begunje 1

Town: Begunje na Gorenjskem Post Code: SI - 4275 Country: Slovenia

Name of Authorised Representative (if applicable): Non applicable

Address: _____

Town: _____ Post Code: _____ Country: _____

Name of Notified Body for **design and construction assessment** (if applicable): Applied at Germanischer Lloyd AG

Address: Vorsetzen 35

Town: Hamburg Post Code: DE - 20459 Country: Germany ID Number: 0098

ECtype-examination Certificate number: IN PROGRESS AT GL Date: (yr/month/day) 2009/--/--

Name of Notified Body for **noise emission assessment** (if applicable): Non applicable

Address: _____

Town: _____ Post Code: _____ Country: _____ ID Number: _____

Module used for construction assessment: A Aa B+C B+D B+E B+F G H

Module used for noise emission assessment : A Aa G H

Other Community Directives applied: /

DESCRIPTION OF CRAFT

Number _____ Craft Identification

S	I	-	E	L	A	3	I	E											
---	---	---	---	---	---	---	---	---	--	--	--	--	--	--	--	--	--	--	--

Brand name of the craft: Elan Type or number: Elan 310

Type of craft: sailboat motorboat inflatable other (specify): _____
Type of main Propulsion: sails petrol engine diesel engine electric motor oars other (specify): _____

Type of hull: monohull multihull other (specify): _____
Type of engine: outboard inboard z or sterndrive without integral exhaust z or sterndrive with integral exhaust other (specify): _____

Construction material: aluminium, aluminium alloys plastic, fiber reinforced plastic steel, steel alloys wood other (specify): _____
Deck: fully decked partly decked open other (specify): _____

Maximum Design Category: A B C D
Engine power: Max. Recommended: 13.3 kW, Installed: 13.3 kW (if applicable)
Length of hull L_A: 9.25 m Beam of hull B_A: 3.22 m Draught T: 1.90 m

This declaration of conformity is issued under the sole responsibility of the manufacturer. I declare on behalf of the craft manufacturer that the craft mentioned above complies with all applicable essential requirements in the way specified (and is in conformity with the type for which above mentioned EC type examination certificate has been issued) – delete text between brackets if no EC type examination certificate has been issued.

Name and function: LUKA KEPEC, Sales Manager Signature and title: LUKA KEPEC
(identification of the person empowered to sign on behalf of the manufacturer or his authorised representative) (or an equivalent marking)

Date and place of issue: (yr/month/day) 2009/ / /

Essential requirements (reference to relevant articles in Annex IA & IC of the Directive)	Standards	Other normative document/ methods	Technical file	Please specify in more detail (*: Mandatory Standards)
General requirements (2)				
Craft Identification Number – CIN (2.1)	<input checked="" type="checkbox"/>	<input type="checkbox"/>	<input type="checkbox"/>	EN ISO 10087:2006
Builder's Plate (2.2)	<input checked="" type="checkbox"/>	<input type="checkbox"/>	<input type="checkbox"/>	EN ISO 14945:2004/AC:2005
Protection from falling overboard and means of reboarding (2.3)	<input checked="" type="checkbox"/>	<input type="checkbox"/>	<input type="checkbox"/>	EN ISO 15085:2003
Visibility from the main steering position (2.4)	<input checked="" type="checkbox"/>	<input type="checkbox"/>	<input type="checkbox"/>	EN ISO 11591:2000
Owner's manual (2.5)	<input checked="" type="checkbox"/>	<input type="checkbox"/>	<input type="checkbox"/>	EN ISO 10240:2004
Integrity and structural requirements (3)				
Structure (3.1)	<input checked="" type="checkbox"/>	<input type="checkbox"/>	<input type="checkbox"/>	EN ISO 12215-1:2000
Stability and freeboard (3.2)	<input checked="" type="checkbox"/>	<input type="checkbox"/>	<input type="checkbox"/>	EN ISO 12217-2:2001
Buoyancy and floatation (3.3)	<input checked="" type="checkbox"/>	<input type="checkbox"/>	<input type="checkbox"/>	EN ISO 12217-2:2001
Openings in hull, deck and superstructure (3.4)	<input checked="" type="checkbox"/>	<input type="checkbox"/>	<input type="checkbox"/>	EN ISO 12216:2002; EN ISO 9093-1:2002; EN ISO 9093-2:2002
Flooding (3.5)	<input checked="" type="checkbox"/>	<input type="checkbox"/>	<input type="checkbox"/>	EN ISO 15083:2003; EN ISO 11812:2001
Manufacturer's maximum recommended load (3.6)	<input checked="" type="checkbox"/>	<input type="checkbox"/>	<input type="checkbox"/>	EN ISO 14946:2001/AC:2005
Liferaft stowage (3.7)	<input type="checkbox"/>	<input checked="" type="checkbox"/>	<input type="checkbox"/>	RSG Guidelines
Escape (3.8)	<input checked="" type="checkbox"/>	<input type="checkbox"/>	<input type="checkbox"/>	EN ISO 9094-1:2003
Anchoring, mooring and towing (3.9)	<input checked="" type="checkbox"/>	<input type="checkbox"/>	<input type="checkbox"/>	EN ISO 15084:2003
Handling characteristics (4)	<input checked="" type="checkbox"/>	<input type="checkbox"/>	<input type="checkbox"/>	EN ISO 8665:1995/A1:2000
Engines and engine spaces (5.1)				
Inboard engine (5.1.1)	<input checked="" type="checkbox"/>	<input type="checkbox"/>	<input type="checkbox"/>	EN ISO 16147:2002
Ventilation (5.1.2)	<input type="checkbox"/>	<input checked="" type="checkbox"/>	<input type="checkbox"/>	GL Rules; Volvo Rules
Exposed parts (5.1.3)	<input type="checkbox"/>	<input type="checkbox"/>	<input type="checkbox"/>	/
Outboard engine starting (5.1.4)	<input type="checkbox"/>	<input type="checkbox"/>	<input type="checkbox"/>	Non applicable
Fuel system (5.2)				
General – fuel system (5.2.1)	<input checked="" type="checkbox"/>	<input type="checkbox"/>	<input type="checkbox"/>	EN ISO 7840:2004; EN ISO 10088:2001; EN ISO 8469:1995/A1:2000
Fuel tanks (5.2.2)	<input checked="" type="checkbox"/>	<input type="checkbox"/>	<input type="checkbox"/>	EN ISO 10088:2001; prEN ISO 21487
Electrical systems (5.3)	<input checked="" type="checkbox"/>	<input type="checkbox"/>	<input type="checkbox"/>	EN ISO 10133:2000; EN ISO 13297:2000; EN 60092-507:2000
Steering systems (5.4)				
General – steering system (5.4.1)	<input checked="" type="checkbox"/>	<input type="checkbox"/>	<input type="checkbox"/>	EN ISO 8847:2004/AC:2005
Emergency arrangements (5.4.2)	<input type="checkbox"/>	<input type="checkbox"/>	<input type="checkbox"/>	Non applicable
Gas systems (5.5)	<input checked="" type="checkbox"/>	<input type="checkbox"/>	<input type="checkbox"/>	EN ISO 10239:2000; EN ISO 14895:2003
Fire protection (5.6)				
General – fire protection (5.6.1)	<input checked="" type="checkbox"/>	<input type="checkbox"/>	<input type="checkbox"/>	EN ISO 9094-1:2003
Fire-fighting equipment (5.6.2)	<input checked="" type="checkbox"/>	<input type="checkbox"/>	<input type="checkbox"/>	EN ISO 9094-1:2003
Navigation lights (5.7)	<input checked="" type="checkbox"/>	<input type="checkbox"/>	<input type="checkbox"/>	prEN ISO 16180
Discharge prevention (5.8)	<input checked="" type="checkbox"/>	<input type="checkbox"/>	<input type="checkbox"/>	EN ISO 8099:2000
Annex I.B – Exhaust Emissions	see the Declaration of Conformity of the Engine Manufacturer			
Annex I.C – Noise Emissions¹	<input type="checkbox"/>	<input type="checkbox"/>	<input type="checkbox"/>	Non applicable
Noise emission levels (I.C.1)	<input type="checkbox"/>	<input type="checkbox"/>	<input type="checkbox"/>	Non applicable
Owner's manual (I.C.2)	<input type="checkbox"/>	<input type="checkbox"/>	<input type="checkbox"/>	Non applicable

¹ Only to be completed for boats with inboard engines or sterndrive engines without integral exhaust

2. WARRANTY CONDITIONS OF YOUR ELAN

2.1. GENERAL WARRANTY CONDITION

2.1.1. The warranty is valid for two years, starting to run from the date of delivery and is strictly limited, at the sole builder's discretion, to the free replacement or repair of any parts which have been recognized as being defective by its technical departments.

No indemnity whatsoever shall be paid in connection thereto.

However by derogation at what is said above:

- The warranty is limited to one year with respect to:
 - boats being used for professional purposes, including but not limited to charter, sailing schools, fishing or workboats,
 - boats built for competition specifically when equipped and/or conceived for racing,
 - one-design boats,
 - parts that rapidly deteriorate due to wear and tear, including but not limited to sails, running rigging batteries, external decorations, cushions, hull bottom protection...,
- Parts or accessories visibly bearing the trademark of another supplier only benefit from the warranty provided by that supplier.

2.1.2. The costs of transporting the boat or any defective part as well as any additional related costs due to the impossibility of using the boat and/or its equipment are to be borne exclusively by the purchaser.

2.1.3. This warranty is only valid after establishing and sending of all bellow documents to Elan Marine QA and AS Dept., according to the conditions specified on each of them

- hand over and commissioning certificate,
- control certificate after first year of use,

Cost related to handling, transportation, standing, sailing for delivery, etc... with regards to these, hand over and control are to be borne exclusively by the purchaser.

2.1.4. The application of this warranty prolongs the warranty period for the sole part or accessory thus repaired or exchanged, during a period equal to the necessary time to perform the warranty work only, provided that said work necessitates at least 7 consecutive days of labour to be performed.

2.1.5. The following and potential consequences thereof are specifically excluded from the warranty:

- effects of normal wear,
- gel-coat fissures, cracks or discoloration,
- deterioration of parts that were replaced by maladapted parts, or from another origin or which were modified or repaired, even partly by a shop not authorized by the builder,
- damage resulting from:

- non-observance of maintenance recommendations as described in the book remitted with the boat, or non-compliance with the normal rules of boat maintenance,
- improper use, especially negligent, reckless, abusive or abnormal use,
- participation in competitions,
- negligence with regards to the use of protective measures when necessary,
- an accident or disaster such as explosion, fire, storm, lightning, transportation, riot, theft or shock.

2.1.6. In order to be covered by the contractual warranties set out above, the purchaser / user of the boat must present its certificate of origin and notify his distributor / seller of any defect(s) in writing. Notification must be detailed and precise and made within 15 days from the day the defect discovered. Upon receipt of notice from the purchaser / user, the distributor / seller shall then have 8 days to notify the builder. His failure to notify the builder within 8 days shall result in his liability for the consequences of his delay.

2.1.7. The dealers, agents or re-sellers of the builder are not qualified to modify the above described warranty but are authorized, for their own account and under their sole responsibility, to grant other warranties that would in no way be under the builder's responsibility.

2.2. HULL DECK WARRANTY

2.2.1. The warranty is valid for 5 years against any manufacturing defect which is recognized as such by the builder's technical departments, and starts to run from the day the boat is put into use or upon the last day of its model year at the latest, that is on August 31 of said year.

However, the warranty is limited to one year after date of first handover for boats:

- being used for professional purposes, including but not limited to charter, sailing schools, fishing or workboats,
- boats built for competition specifically when equipped and/or conceived for racing,
- of one-design nature.

The warranty is strictly limited to the free repair of above-mentioned manufacturing defects, either in the builder's yards or by a repair shop or shipyard chosen by the builder. No indemnity whatsoever shall be paid in this respect.

Any event which affects the structure of the boat and which is not the result of a manufacturing defect under warranty, which may or may not have qualified for a reparation of the hull and deck, will result in the immediate cancellation of the warranty, without prejudice.

The costs of transportation, as well as the possible costs resulting from the loss of use of the boat will be entirely borne by the buyer.

The application of the warranty prolongs the warranty period on the repair works during a period equal to the necessary time to perform the warranty work only, provided that said work necessitates at least 7 consecutive days of labour to be performed.

The following and potential consequences thereof are specifically excluded from the warranty:

- effects of normal wear.
- gel-coat fissures, cracks or discoloration,
- damage resulting from:
 - non-observance of maintenance recommendations as described in the book remitted with the boat, or non-compliance with the normal rules of boat maintenance,
 - improper use, especially negligent, reckless, abusive or abnormal use,
 - participation in competitions,
 - negligence with regards to the use of protective measures when necessary,
 - an accident or disaster such as explosion, fire, storm, lightning, transportation, riot, theft or shock.

2.2.2. In order to be covered by the contractual warranties set out above, the purchaser / user of the boat must presents its certificate of origin and notify his distributor / seller of any defect(s) in writing. Notification must be detailed and precise and made within 15 days from the day the defect discovered. Upon receipt of notice from the purchaser / user, the distributor / seller shall then have 8 days to notify the builder. His failure to notify the builder within 8 days shall result in his liability for the consequences of his delay.

2.2.3. The dealers, agents or re-sellers of the builder are not qualified to modify the above described warranty but are authorized, for their own account and under their sole responsibility, to grant other warranties that would in no way be under the builder's responsibility.

3. IMPORTANT INFORMATION

3.1. DEGREES OF DANGER

This manual used the following degrees of danger:

DANGER:	Denotes that an extreme intrinsic hazard exists which would result in high probability of death or irreparable injury if proper precautions are not taken.
WARNING:	Denotes that a hazard exists which can result in injury or death if proper precautions are not taken.
CAUTION:	Denotes a reminder of safety practices or directs attention to unsafe practices which could result in personal injury or damage to the sailing yacht or components.

3.2. LABELS ON BOARD

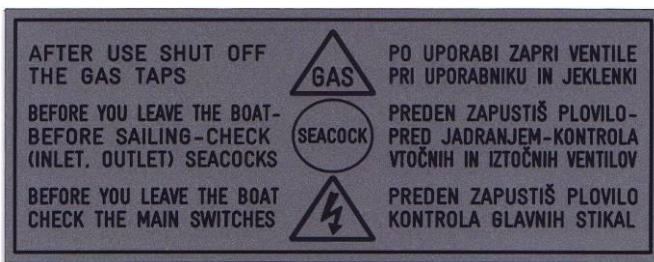

General warning label



Fire extinguisher position



Cooker warning label

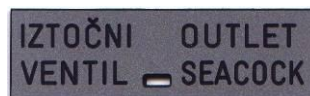

Outlet seacock



Emergency exit



Main switch label



Water tank connection



Inlet seacock

Figure 1

3.3. LIABILITY OF THE OWNER/OPERATOR

Before sailing, the sailing yacht owner/operator should read this manual and familiarize himself / herself with its contents, in particular with all the warnings relating to safe use and emergency procedures. It is the responsibility of the owner to ensure that, when sailing, the sailing yacht is equipped with all the (safety) equipment required under the law. The owner/operator shall also inform all the other crew members about the proper use of the craft and equipment and the emergency procedures.

3.4. FIRE PROTECTION AND ESCAPE PLAN

This sailing yacht is equipped with portable fire extinguishers of the following extinguishing capacities and at the following locations (see Fig. 2):

No.	Location	Capacity
1	In the cockpit locker	1 kg
2	At the navigation table	1 kg

In case of need for evacuation, use the following escape routes:

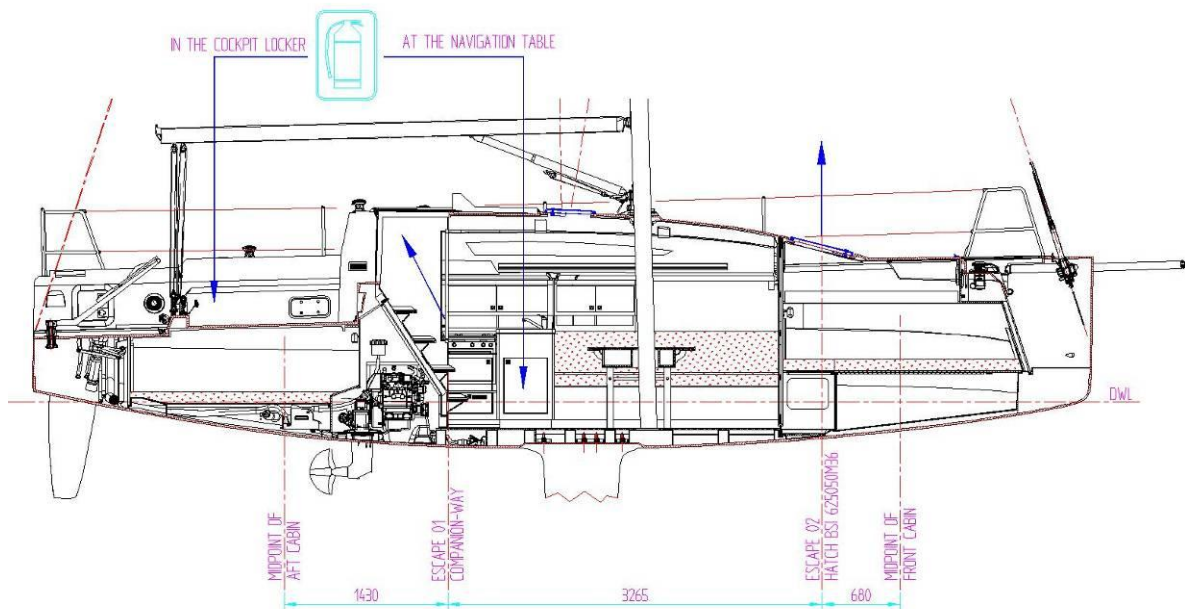

Figure 2

Keep the bilges clean and check for fuel and gas vapours at regular intervals.

It is the responsibility of the sailing yacht owner/operator to:

- Have the fire-fighting equipment checked at the intervals indicated on the equipment.
- Replace the fire-fighting equipment if expired or discharged by devices of identical or greater fire-fighting capacity.
- Inform members of the crew about the location and operation of the fire-fighting equipment and the location of the escape routes.

- In case the fire in engine room use fire port hole located on the companionway.
- Ensure that the fire-fighting equipment is readily accessible when the craft is occupied.

WARNING: - **NEVER** obstruct passageways to exits and hatches.

- **NEVER** obstruct safety controls, e.g. fuel valves, gas valves, switches of the electrical system.
- **NEVER** obstruct portable fire extinguishers stowed in lockers.
- **NEVER** leave the craft unattended when cooking appliances are in use.
- **NEVER** use gas light in the craft.
- **DO NOT** modify any of the craft's systems (especially electrical, fuel, and gas).
- **NEVER** fill the fuel tank or replace gas bottles when the engine is running or when cooking appliances are in use.
- **NEVER** smoke while handling fuel or gas.
- **DO NOT** fit free hanging curtains or other fabrics in the vicinity of or above the cookers or other open flame devices.
- **DO NOT** store combustible material in the engine room.

3.5. PRE-DEPARTURE CHECK LIST

- Close the portlights and hatches.
- Check the position of all the inlet/outlet seacocks in the hull.
- Open the engine cooling valve and close all the other valves, including water tank connection; do not forget to close them if they are used during sailing.
- Switch on the main switches of the engine and other users.
- Check if cooling water runs through the engine exhaust; if not, check the water pump.
- Check if the bilges are clean and if the bilge pumps operate properly.
- Check the navigations lights.
- Check the required safety equipment.

3.6. WATER INTAKE DURING SAILING AND STRANDING

If during sailing you notice water in the craft, stay calm and immediately check if all the seacocks are closed and turn on the bilge pumps. Use a manual bilge pump as well to pump the water out. Switch off the engine and close the engine cooling valve. Close the tank valves as well. Try to find out the cause of the leak as quickly as possible. If you fail to find out the cause and if the water level in the craft continues to rise, start evacuation procedures.

If you run aground while sailing, open the inspection covers in the saloon floor and immediately check for any leaks at the keel screws. Through the stowage compartment check the installation of the steering wheel as well. In case of a leak, follow the directions in the previous paragraph and have the sailing yacht lifted from water as soon as possible.

3.7. CLOSING UP YOUR CRAFT AFTER SAILING CHECK LIST

1. Close all inlet/outlet seacocks in the hull.
2. Turn off the electrical system.
3. Turn off the gas valve on the gas bottle.
4. Switch on bilge pump (if automatic) and pump the bilge.
5. Close all the portlights and hatches.

3.8. CRAFT IDENTIFICATION, BUILDER'S PLATE

The sailing yacht has moulded Craft Identification Number (CIN) visible on the starboard side of the transom.

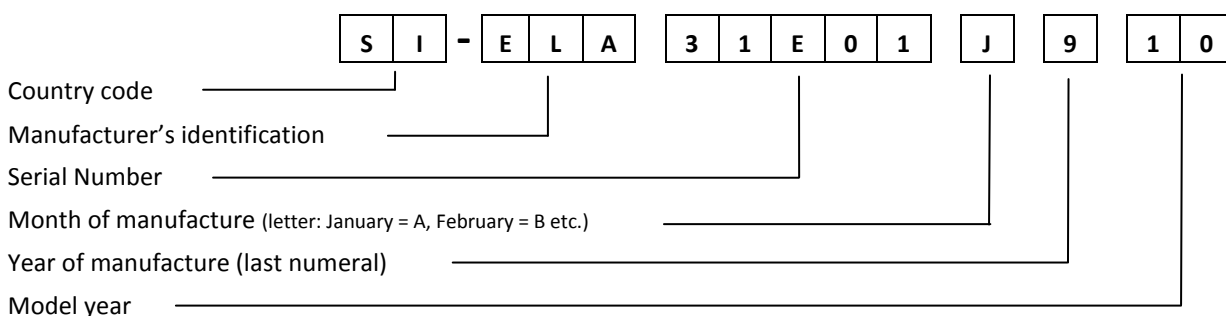

The duplicate CIN plate is fastened on innerhull structure in the starboard cockpit stowage.

The builder's plate is readily visible, located in the cockpit, with the following information:

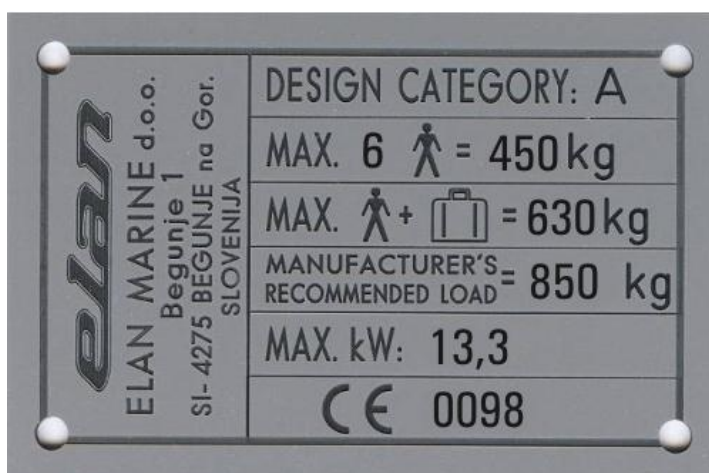

- manufacturer's name
- the CE mark followed by the ident.number of the notified body ("0098" for "Germanischer Lloyd")
- the design category: A B C D
- the number of persons recommended, for which the craft is designed to carry when underway
- manufacturer's recommended load

4. TECHNICAL SPECIFICATIONS

4.1. TECHNICAL DATA

Boat Type	Elan 380
Boat Class	Sailboat
Boat Design Category	A "Ocean"
CIN	SI-ELA31E_____
Manufactured by	ELAN MARINE, d.o.o. Begunje 1, 4275 Begunje na Gorenjskem, Slovenia
Certification	Examination Report Module B+C
Certificate No.	
Notified body	GERMANISCHER LLOYD Head office Vorsetzen 35, D-20459 Hamburg, Germany
Length max.	9,25 m
Hull length	9,25 m
Length at waterline	8,71 m
Beam max.	3,22 m
Draft	1,90 m
Airdraft (incl. 1m antenna)	15,30 m
Unladen weight	3750 kg
Manufacturer's recommended load	850 kg
Displacement max.	4600 kg
Ballast	1040 kg
Engine power max.	13,3 kW / 18 hp
Fuel capacity	45 litres
Water capacity	140 litres
Holding tank (optional)	70 litres
Gas bottles (propane/butane)	2 kg
Maximum crew	6 persons
Cabins	2
Berths	4 + 2
Mainsail	30,15 m ²
Genoa	23,47 m ²
Genaker	75,00 m ²
I	12,25 m
J	3,58 m
P	12,05 m
E	4,13 m
Design	Humphreys Yacht Design

4.2. DEFINITION OF DESIGN

ELAN 310 is designed and built in conformity with the requirements of the "A" ocean sailing design category. The "A" category sailing yacht is designed and built for sailing in waves up to 7 m and winds up to 10 Beaufort, i.e. 55 knots, 28 m/s or 100 km/h. It has to be suitable for longer cruises, for instance ocean sailing as well as for coast sailing in the regions that are not protected against winds and waves for several hundred miles.

4.3. MAXIMUM TOTAL LOAD (displacement max)

Keep the total weight of boat provisions, miscellaneous equipment not supplied by manufacturer and persons on board, below maximum total load and suitably distributed.

5. GENERAL ARRANGEMENT

5.1. DECK LAYOUT

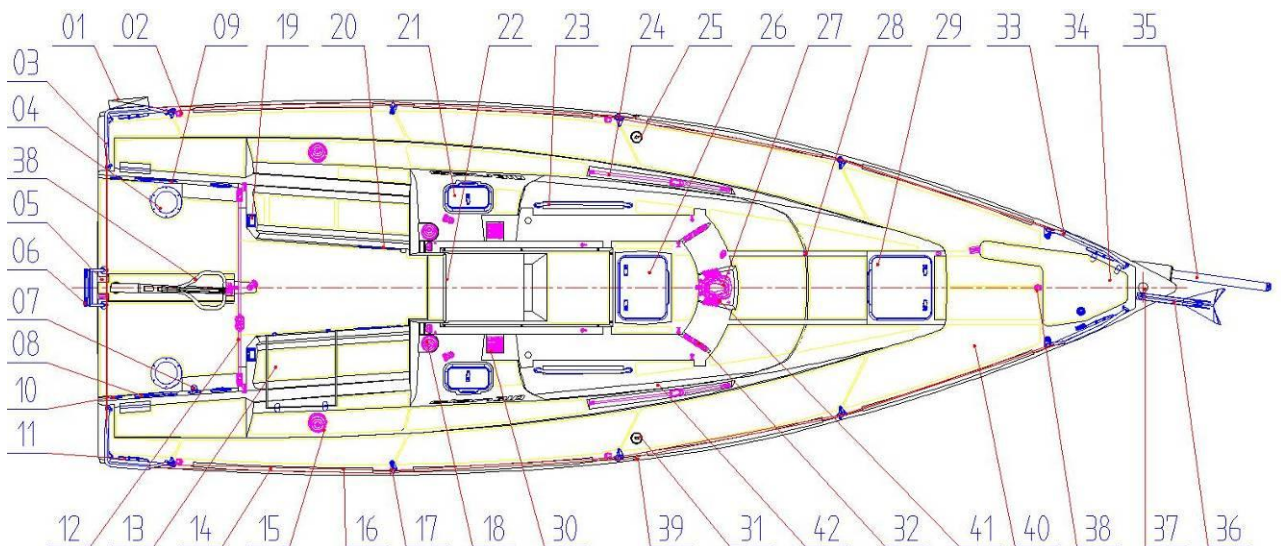

Figure 3

- | | | |
|------------------------------|------------------------------|-----------------------------|
| 1. Horseshoe lifebuoy | 15. Genoa winches 35.2 STA | 29. Escape hatch |
| 2. Pad eye | 16. Lifelines | 30. Stoppers |
| 3. Pushpit | 17. Stanchions | 31. Water filler |
| 4. Rudder bearing covers | 18. Halyard winches 20.2 STA | 32. Organizers |
| 5. Backstay system | 19. Autopilot display | 33. Bow pulpit |
| 6. Folding swimming ladder | 20. Cockpit portlights | 34. Anchor storage cover |
| 7. Engine lever | 21. Hatch | 35. Sliding bowsprit |
| 8. Gas bottle compartment | 22. Sliding hatch | 36. Anchor bow roller |
| 9. Storage box | 23. Grabrail | 37. Forestay fitting |
| 10. Hand operated bilge pump | 24. Genoa tracks & systems | 38. Steering tiller |
| 11. Mooring cleats | 25. Fuel filler | 39. Chainplates |
| 12. Mainsheet track & system | 26. Hatch | 40. Anti-slip surfaces |
| 13. Cockpit locker | 27. Mat deck ring | 41. Mast base blocks |
| 14. Toe rail | 28. Bullseye | 42. Custom glass portlights |

WARNING:

- Keep portlights, windows, washboards, doors, hatches and ventilation openings closed when appropriate, e.g. in rough weather or at surfing speeds.
- Secure unfixed equipment safely when underway.
- If a liferaft shall be fitted, recommended stowage area is on the deck in front of the mast.
- If a liferaft is fitted please strictly follow instructions of liferaft manufacturer.
- In case if somebody falls overboard, use swimming ladder fitted on the aft to climb back.
- If cockpit lockers are taken out, the sealant must be ensured when they are fitted back.

5.2. INTERIOR LAYOUT

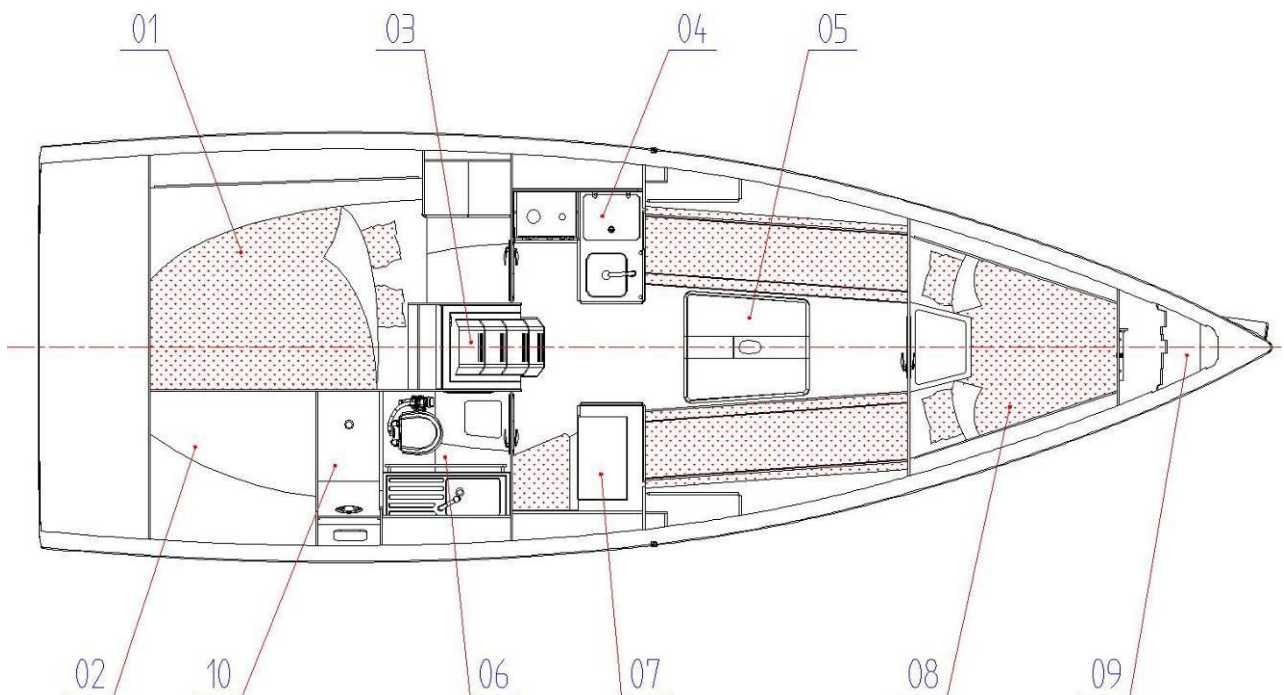

Figure 4

- | | | |
|--------------------------------------|---------------------|------------------|
| 1. Aft cabin | 4. Galley | 8. Forward cabin |
| 2. Storage | 5. Saloon | 9. Anchor locker |
| 3. Companionway / engine compartment | 6. Head / shower | 10. Wet locker |
| | 7. Navigation table | |

5.3. PROFILE

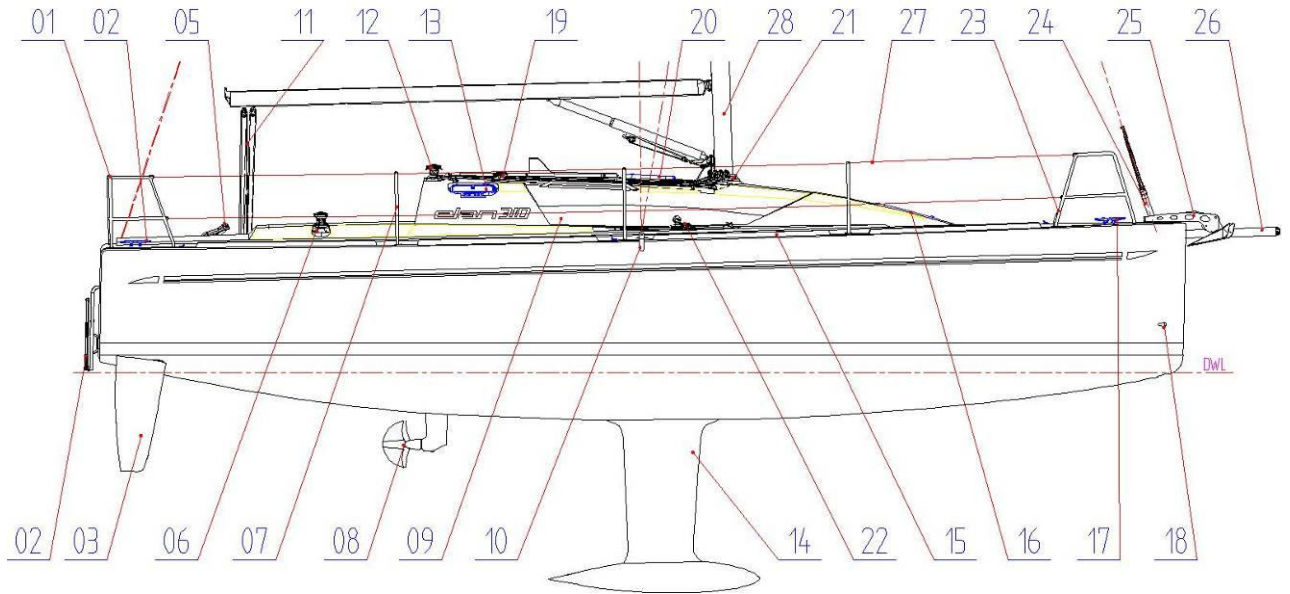
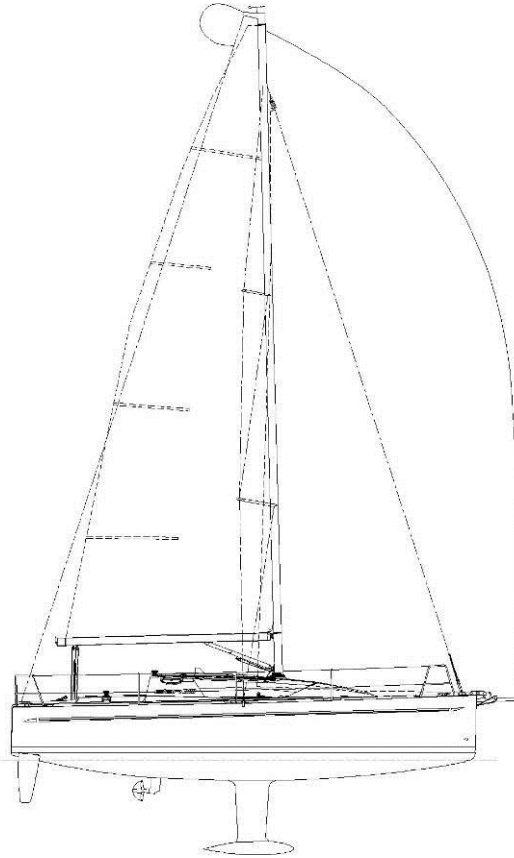

Figure 5

- | | | |
|----------------------------|----------------------------|--------------------------|
| 1. S/S pushpit | 11. Mainsheet system | 21. Mast deck ring |
| 2. Folding swimming ladder | 12. Halyard winch 20.2 STA | 22. Genoa track & system |
| 3. Twin rudders | 13. Hatch | 23. Bow pulpit |
| 4. Mooring cleat | 14. Keel | 24. Forestay |
| 5. Steering tiller | 15. Toe rail | 25. Anchor bow roller |
| 6. Genoa winch 35.2 STA | 16. Escape hatch | 26. Sliding bowsprit |
| 7. Stanchions | 17. Mooring cleat | 27. Life lines |
| 8. Propeller | 18. Anchor drainage | 28. Keel stepped mast |
| 9. Custom glass portlight | 19. Stoppers | |
| 10. Chainplates | 20. Hatch | |

6. PROPULSION SYSTEM

6.1. SAILS AND MAST



Mainsail: 30,15 m²
Genoa: 23,40 m²
Gennaker: 75,00 m²

I = 12,25 m
J = 3,58 m
P = 12,05 m
E = 4,13 m

Figure 6

6.2. ENGINE SYSTEM

CAUTION:

- Follow the instructions for use supplied by the engine manufacturer, especially with regard to the RPM and load of a new engine.
- When shifting from one gear to another via the idle position, keep the handle in the idle position long enough for the engine to rotate at the minimum rpm.
- Check the engine oil level.
- When putting in reverse, hold the steering wheel firmly to avoid breaking the steering mechanism.
- Shut the engine down before opening the engine compartment. The engine has rotating and moving parts that can be dangerous.
- Never switch the main engine switch or turn the key with the engine is running.
- Do not operate the starter for more than 10 seconds at a time. If the engine does not start; wait for at least 30 seconds before trying again.
- Each engine has its critical RPM which is indicated by an increase in engine vibrations. You should always avoid this speed.

6.2.1. ENGINE OPERATION

The following instructions for engine operation are provided for information purposes only and do not include all the details of engine operation and maintenance. For detailed information see the operation instructions, supplied by the engine manufacturer, which are included in the Owner's Manual. Before operating the engine, you should familiarize yourself with those instructions.

The warranty will be valid only provided the maintenance instructions are strictly observed. For details see the enclosed instructions supplied by the engine manufacturer.

Before starting the engine:

- Switch on the main engine switch.
- Check and open the engine coolant water intake valve.
- Check and open the fuel supply valve on the fuel tank.

Starting the engine:

- Put the throttle into the idle position by pressing the button and shifting the handle forwards/backwards - always away from any obstacles - by 30° (the engine is ready to be started at appropriate throttle).
- Press the button to start the engine. When the engine starts, release the button.
- Back the throttle off to the idle (central) position and from that position move the throttle up or down (without pressing the button) and the craft will move forwards or backwards depending on the position of the handle.
- Make sure all the warning lamps and sound alarm are off and the engine is adequately cooled - check the coolant water pump function.

Stopping the engine:

- Put the handle into the idle position and wait a few seconds for the engine to rotate at the minimum RPM.
- Press the button to shut-off the engine. When the engine stops, the warning lamps go on and the sound alarm sounds.

CAUTION: - When sailing with inclination over 20 degrees, stop the engine.
- All fuel capacity can not be used. Make sure that the tank will be filled over 10 % of its capacity.

6.2.2. ENGINE AND PROPELLER INSTALLATION

The standard version of the ELAN 310 is equipped with a VOLVO D1-20 engine - sail drive version. The engine runs on normal diesel fuel D2. It is cooled with seawater in a closed cooling circuit. Access to the engine is possible from the front by lifting the companionway and via the engine compartment covers in the aft cabin or head/shower. For further information see operation instructions supplied by the engine manufacturer.

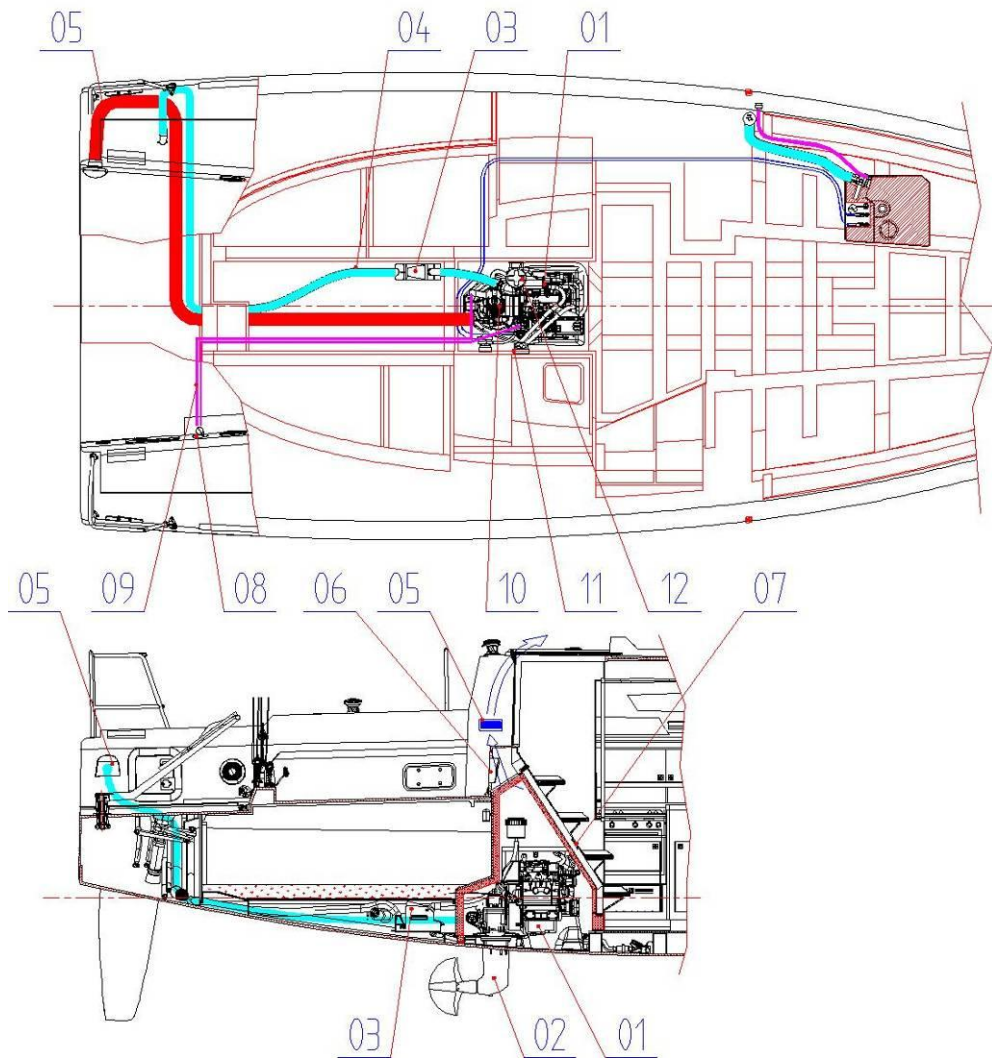

Figure 7

- | | | |
|----------------------------|---------------------------|--|
| 1. Engine Volvo D1-20 | 6. Engine panel | 10. Sea water inlet seacock
(on sail-drive) |
| 2. Sail-drive gearbox | 7. Fire extinguisher hole | 11. Sea water air vent |
| 3. Exhaust waterlock | 8. Engine lever | 12. Sea water filter |
| 4. Exhaust hose | 9. Engine control cables | |
| 5. Engine room ventilation | | |

WARNING: - Do not obstruct fuel lines (possible damage).
 - Do not put flammable material in contact with hot engine parts.

6.2.3. FUEL SYSTEM

The fuel required for engine operation is stored in a fuel tank. The fuel tank has a capacity of 45 liters. The fuel tank is stowed under the port side saloon seat (see Fig. 8). Fuel tank is accessed from saloon by lifting the seat panels.

DANGER: - When filling the tank, turn off the engine and do not smoke.

Filling the fuel tank:

- Fill the fuel tank with diesel via the deck filler. The position of the deck filler is shown in Fig.8
- The fuel filler is marked "DIESEL". Unscrew the plug using a winch handle.
- Before filling the tank, close the portlights in vicinity of the fuel filler.
- Fill the fuel tank slowly in order to avoid spilling fuel on the deck.
- In case of spilling fuel on the deck, clean it immediately using a detergent and a large amount of fresh water.
- Keep the fuel tank full because a low fuel level can cause air penetration and improper engine operation and stoppage.
- Close the fuel filler carefully and screw it tight.

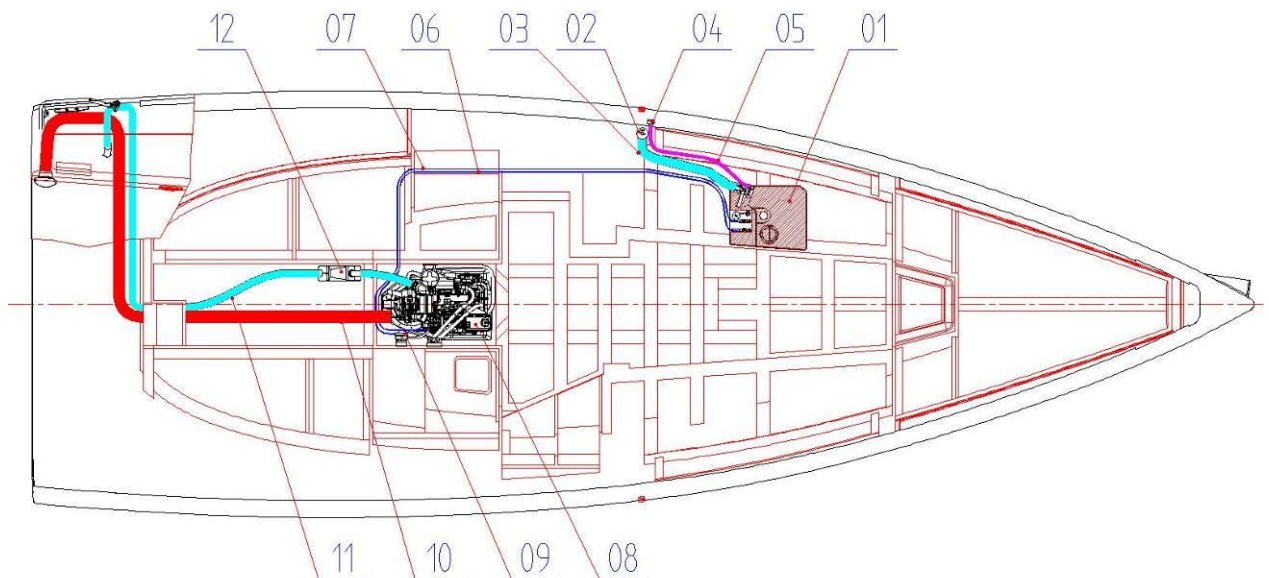

Figure 8

- | | | |
|---------------------------|-------------------------|-------------------------|
| 1. Fuel tank 45 l | 5. Diesel tank air vent | 9. Diesel fuel filter |
| 2. Fuel inlet deck filler | 6. Fuel line to engine | 10. Engine ventilation |
| 3. Diesel tank inlet hose | 7. Engine overflow line | 11. Engine exhaust hose |
| 4. Diesel air vent | 8. Diesel engine D1-20 | 12. Exhaust waterlock |

7. SYSTEMS AND CIRCUITS

7.1. POSITION OF SEACOCKS AND THROUGH-HULL FITTINGS

CAUTION: -Keep the seacocks closed when not in operation to avoid the possibility of water penetration or leakage.
 - When sailing, the seacocks must be kept closed.
 - When sailing close the water tank connection valve.

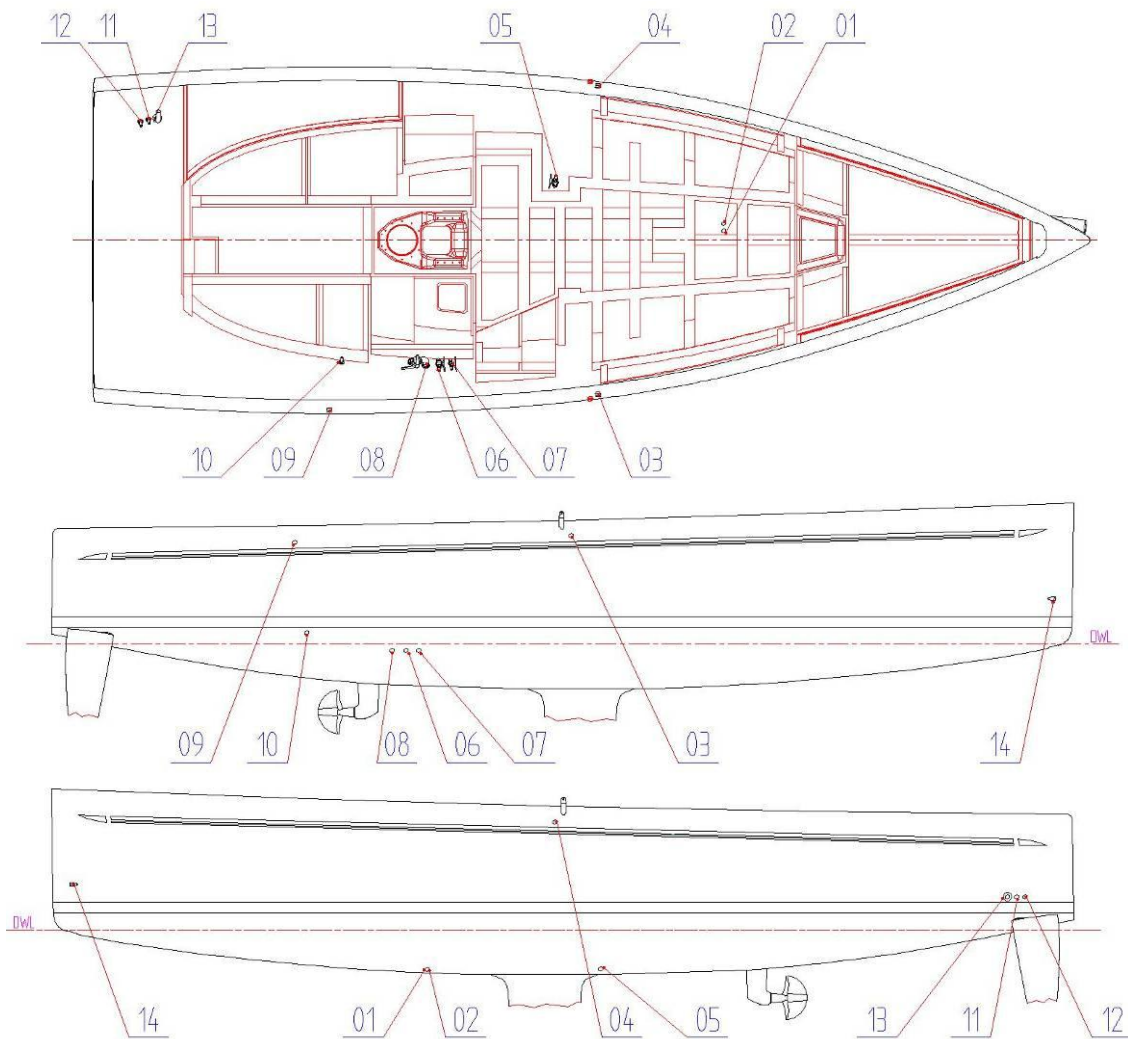

Figure 9

- | | |
|--|---|
| <ol style="list-style-type: none"> 1. Depth sounder 2. Speedometer 3. Through-hull – water tank air vent 4. Through-hull – diesel tank air vent 5. Seacock – galley sink waste outlet 6. Seacock – toilet sink waste outlet 7. Seacock – toilet sea water inlet | <ol style="list-style-type: none"> 8. Seacock – toilet waste outlet 9. Through-hull - waste tank air vent 10. Through-hull – shower bilge outlet 11. Through-hull - electric bilge pump outlet 12. Through-hull - manual bilge pump outlet 13. Through-hull – Engine exhaust 14. Through-hull – Chain storage outlet |
|--|---|

OPERATION:

The seacock is **open** when the lever is in line with the pipe.

The seacock is **closed** when the lever is at a right angle (90°).

CAUTION: - Keep seacocks, cockpit drains, bungs and other opening/closing devices in the hull closed or open, as appropriate, to minimise the risk of flooding.

7.2. WATER SYSTEMS

7.2.1. FRESH WATER SYSTEM

TANKS

The sailing yacht is equipped with fresh water tanks (see Fig.10). They are filled via fresh water fillers (see Fig.10) marked "WATER". Unscrew the plug using a winch handle. A fresh water level indicator is located on the electrical control panel. The tanks are connected, so that the water level is equal in all tanks. At the top of the tanks, there is an opening for inspection and cleaning.

CAUTION: - After filling the tanks, close the fillers carefully and screw them tight to avoid the risk of seawater entering the fresh water tanks.
- To avoid the risk of contaminating one liquid with the other one, never fill fresh water and fuel at the same time.

CONSUMERS

An electrical fresh water pump (see Fig.10) located inside the galley is used to pump fresh water to the consumers. The fresh water pump is automatically shut off by a pressure valve when pressure reaches 1.5 bar.

CAUTION: - Take care not to operate the electric pump when the fresh water tanks are empty.
- Always open the sink and waste water seacocks when using fresh water from the tanks.
- When sailing close the water tank connection valve.

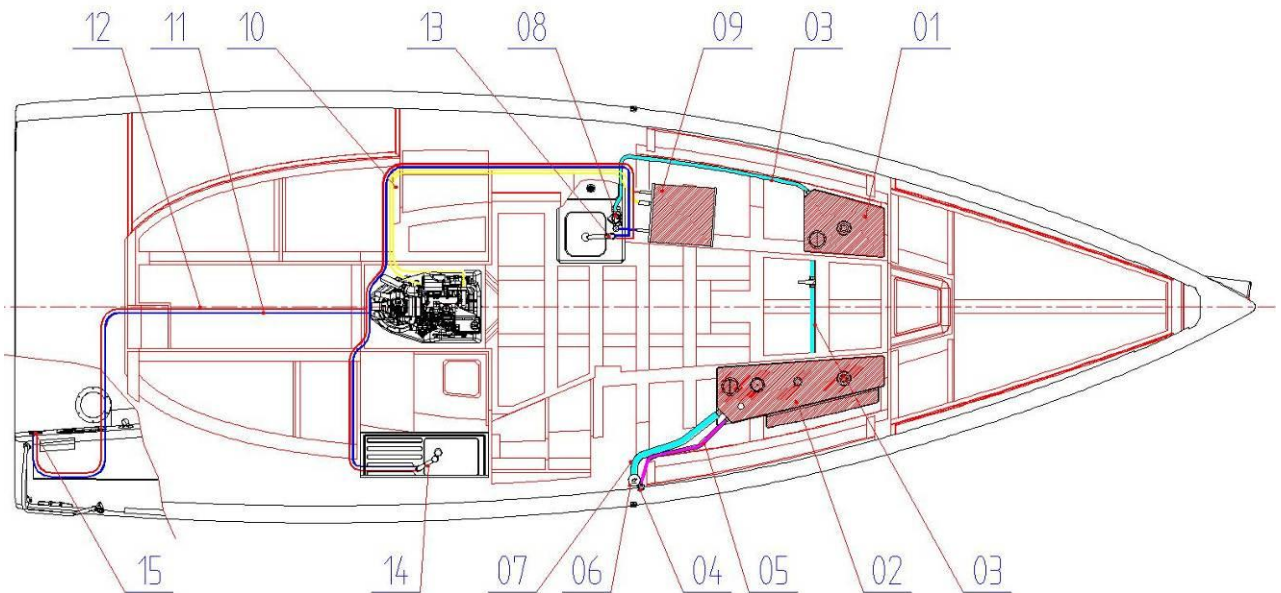

Figure 10

- | | |
|--|-------------------------------------|
| 1. Fresh water tank - port ~ 45 l | 9. Water heater |
| 2. Fresh water tank - starboard ~ 95 l | 10. Engine to water heater exchange |
| 3. Water tank connection | 11. Cold water tube |
| 4. Air vent | 12. Hot water tube |
| 5. Tank ventilation hose | 13. Galley tap |
| 6. Fresh water deck filler | 14. Head toilet tap |
| 7. Fresh water filler hose | 15. Cockpit shower tap |
| 8. Electric fresh water pump | |

7.2.2. HOT WATER SYSTEM

A separate hot water system leads hot water from the water heater (see Fig. 10) to the users. The hot water system is filled with fresh water from the fresh water system. When the empty hot water system is being filled, open the hot water seacocks at the taps to let air out of the system.

For further details see the instructions supplied by the manufacturer and included in the Owner's Manual. Before using the hot water system, you should familiarize yourself with those instructions.

The warranty will be valid only provided the maintenance instructions are strictly observed. For details see the enclosed instructions supplied by the engine manufacturer.

Fresh water is heated in two ways:

- With the coolant water from the engine when the engine is in operation. The coolant water runs through the water heater where it is used to heat the fresh water filled from the fresh water system.

- With an electrical spiral that can be turned on when the boat is connected to a 230V supply.

CAUTION: - Do not operate the water heater if the fresh water system is empty.
 - Do not turn the water heater on if the fresh water tanks are empty.

7.3. SEA AND WASTE WATER SYSTEM

Sea water is used for flushing the toilets and as extra water for the sink (optional). The toilets are flushed with a manual pump that is built into the toilet. The sea water for the sink is pumped via foot pump. The waste water from the toilets and the wash basins in the toilets and the sink is emptied via outlet seacocks.

CAUTION: - **Never** use the waste water pump with the outlet seacock closed.
 - **Never** use any other but thin absorbent toilet paper and never too much. Any other kind may damage the pump.
 - Follow carefully the instructions for use and precautions marked on the pump.
 - If the pump breaks down, it will have to be taken apart and cleaned.
 - The mechanism is maintained by rinsing the whole system with fresh water. This is done by operating the pump.
 - **NOTE:** Observe local regulation on discharge.

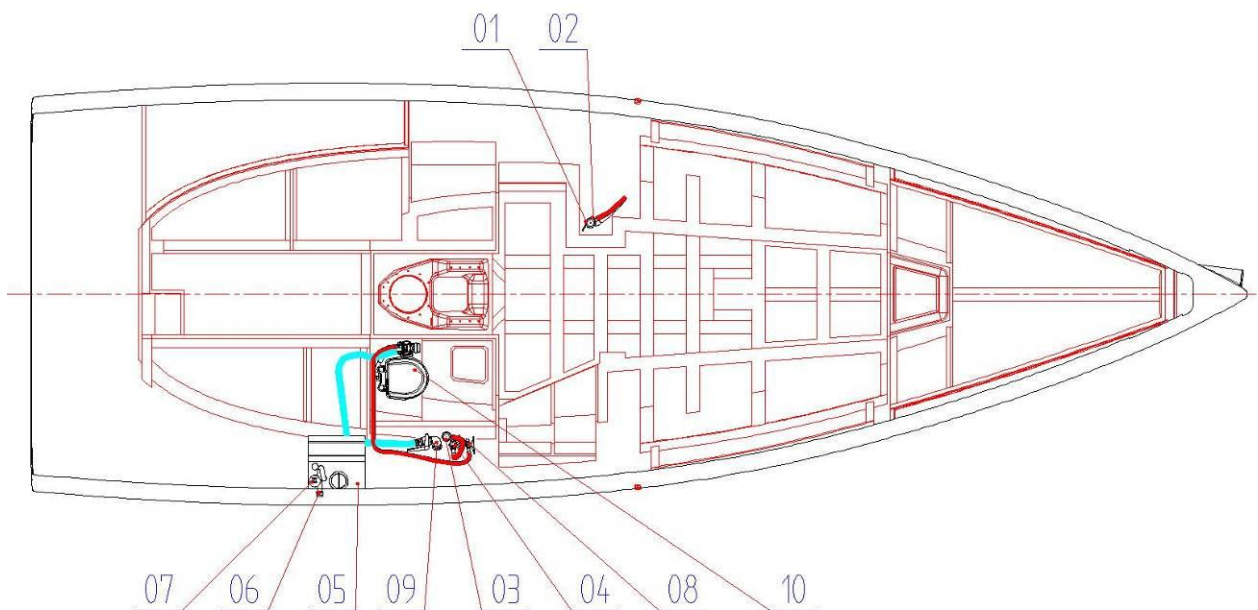

Figure 11

- | | |
|------------------------------------|-----------------------------------|
| 1. Galley sink outflow | 6. Holding tank air vent |
| 2. Galley sink water seacock | 7. Waste tank dockside suction |
| 3. Toilet sink outflow | 8. Toilet sea water inlet seacock |
| 4. Toilet sink water seacock | 9. Toilet waste water seacock |
| 5. Waste water holding tank ~ 70 l | 10. Manual toilet |

7.4. BILGE WATER SYSTEM

The bilge strainer is located under the saloon floor. Lifting the boards in front of the companionway will allow you access to the bilge pump via a bilge strainer.

CAUTION: - Check the bilge pump for bilge water before leaving dock, during sailing and when leaving the boat for a longer period.
 - Switch on the bilge water pump switches on the control panel and check the operation of the bilge pump.
 - Follow carefully the instructions for use and precautions marked on the pump.

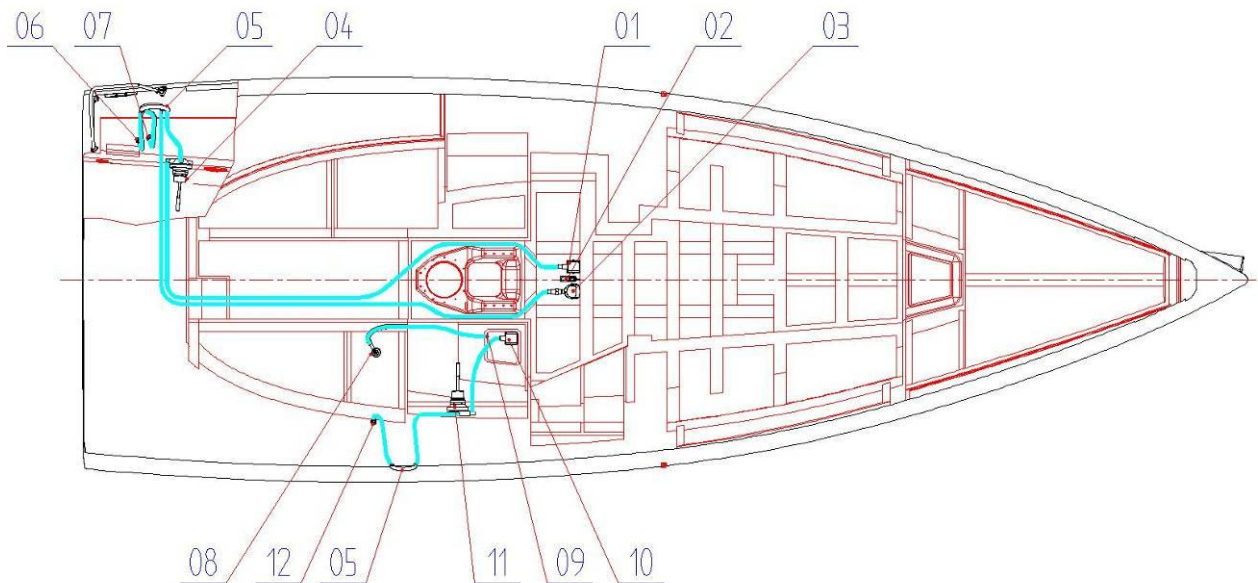

Figure 12

- | | |
|--|---------------------------------|
| 1. Retention bilge strainer | 7. Electrical bilge pump outlet |
| 2. Retention bilge strainer - float switch | 8. Wetlocker strainer |
| 3. Electrical bilge water drain pump | 9. Wetlocker outlet |
| 4. Manual bilge water drain pump | 10. Shower bilge strainer |
| 5. Goose-neck | 11. Manual shower drain pump |
| 6. Manual bilge pump outlet | 12. Shower bilge water outlet |

7.5. GAS SYSTEM

The boat is equipped with a gas cooker. A copper tube leads from the gas bottle to the cooker. A certified rubber hose is used to connect the cooker and the gas bottle to the copper tube. The screw valve on the gas bottle is connected to a safety non-return valve. There is an extra gas valve installed in the galley, marked with a label (see Fig. 1). The gas bottle of LPG propane butane is stowed in the stowage compartment under the steering mechanism cover in the cockpit (see Fig. 13).

Close gas supply valves and cylinder valve when appliances are not in use. **Close valves immediately in an emergency.**

Be sure appliance valves are closed before opening cylinder valve.

Test the LPG system regularly; check all connections for leakage by manual look-testing or by testing with soapy water or detergent solution (with appliance burner valve closed and cylinder and system valves open). If leakage is present, close cylinder valve and have the system repaired before further use. System repairs should be made by a competent person.

CAUTION: - DO NOT use solutions containing ammonia.

WARNING: - NEVER USE FLAME TO CHECK FOR LEAKS!

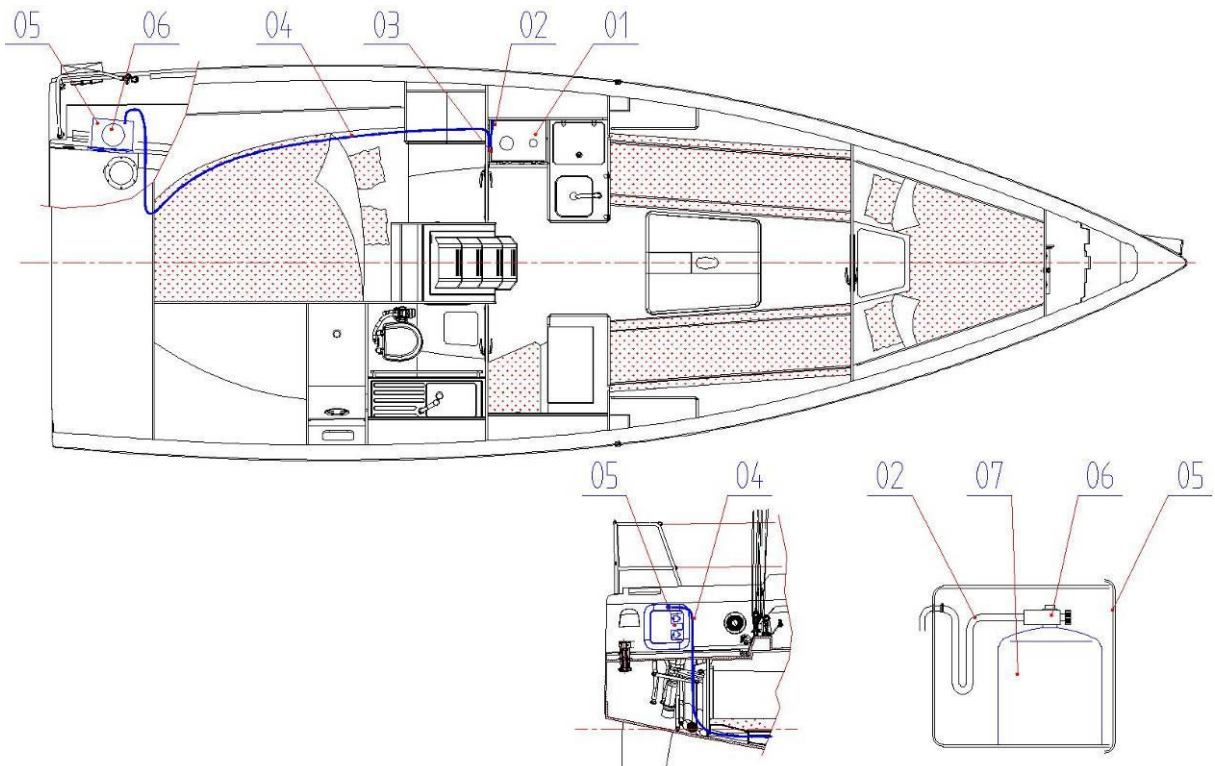

Figure 13

- | | |
|-----------------------|---------------------------|
| 1. Gas cooker | 5. Gas bottle compartment |
| 2. Flexible hose line | 6. Safety screw valve |
| 3. Gas valve | 7. Gas bottle |
| 4. Copper tube | 8. Overboard drainage |

Fuel burning appliances consume cabin oxygen and release combustion products into the craft. Ventilation is required when appliances are in use. Never obstruct ventilation openings.

Gas cylinder must be stored only in specified locker. Do not use LPG cylinder housing or lockers for storage of any other equipment.

DANGER: - Avoid asphyxiation. Provide ventilation when the stove is in use.
- Do not use for space heating.
- Do not smoke or use open flame when replacing LPG bottles.

Never leave craft unattended when LPG consuming appliances are in use.

Hoses in the LPG system must be inspected regularly, at least annually and replaced if any deterioration is found.

Keep valves on empty cylinders closed and disconnected. Keep protective covers, caps or plugs in place. Store reserves or empty cylinders on open decks or in gas-tight lockers, which are vented overboard and intended for this purpose.

The ambient operating temperature range of the LPG system is -40 to +40°C for Propane - Butane LPG.

Avoid contact of materials with naked flame and other hot area.

DANGER: - In case you smell gas or the flame goes out, turn all the valves off and create a draught to allow the gas to escape. Find the origin of the problem.

WHEN LEAVING YOUR BOAT OR WHEN THE SYSTEM IS NOT IN USE, DO NOT FORGET TO CLOSE THE SCREW VALVE ON THE GAS BOTTLE AND THE SAFETY VALVE IN THE GALLEY.

Changing the gas bottle:

1. Close the gas valve under the cooker.
2. Close the screw valve and the safety valve on the gas bottle.
3. Put the gas bottle into the compartment under the helmsman's seat.
4. Open the screw valve on the gas bottle.
5. Open the gas valve to the left of the cooker and turn the cooker on.

7.6. ELECTRICAL SYSTEMS

7.6.1. 12 V SYSTEM

The boat is equipped with 12 V AGM (gel) batteries. The number of batteries depends on the equipment installed (Standard 2). The batteries are charged via a alternator driven by the boat's engine. They can also be charged via a battery charger when the boat is connected to an external 230 V supply.

CAUTION:

- In case of disassembly, first interrupt the minus cable.
- If Webasto heating system is installed, please follow the manufacturer's User's manual.
- It is recommended that any faulty original battery be replaced with a similar GEL battery.
- In case you fitted an ACID battery, it is obligatory to put it in an acid proof box to prevent eventual acid spillage.

All electrical consumers are connected via control panel. Each consumer is equipped with an automatic circuit breaker, a signal light and a switch to turn it ON/OFF. There are three main switches, one for the engine system, one for the anchor windlass and one for the other consumers. **The main switches are located under the chart table.**

On the electrical control panel, there are three TEST buttons. When pressed, they indicate the operating voltage of the batteries, the fresh water level and the fuel level.

WARNING:

- Never work on the electrical installation without disconnecting the power supply.
- The batteries must be kept carefully fastened.
- Do not store conducting objects near the batteries (metal tools).
- Never modify an electrical installation.
- When leaving the boat, switch off all the main switches.

CONTROL PANEL 12 V

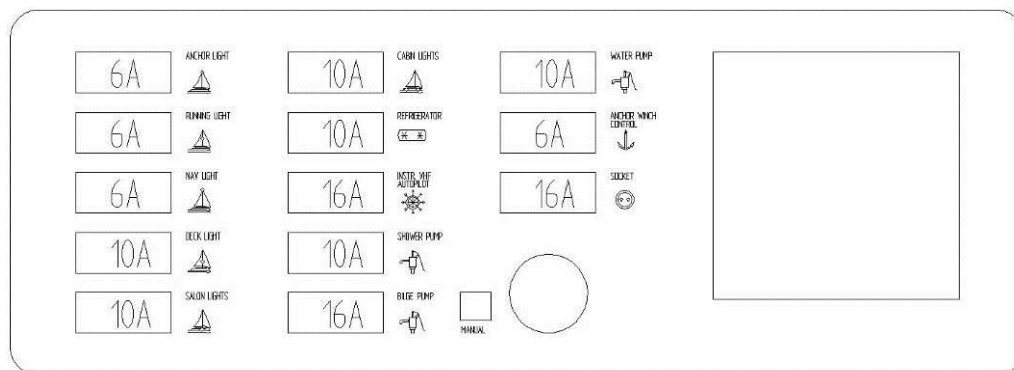

Figure 14

7.6.2. 230 V SYSTEM

The boat is optionally equipped with a 230 V electrical circuit. The shore power plug is located in the cockpit. In addition to the battery charger, the circuit also comprises sockets for 230 V consumers.

WARNING:

- Never work on the electrical installation without disconnecting the power supply. An electrical shock can cause fire.
- Before connecting the cable on the shore, connect it to the boat first.
- Disconnect the cable after use.
- First switch off the main switch in the boat, then disconnect the cable on the shore and last, disconnect it on the boat.
- Do not soak the catches of the cable in the water.
- Do not modify any terminals of the electrical cable.
- Never modify an electrical installation.

CONTROL PANEL 230 V

ELECTRICAL PANEL AC 230V FUSES CAPACITY

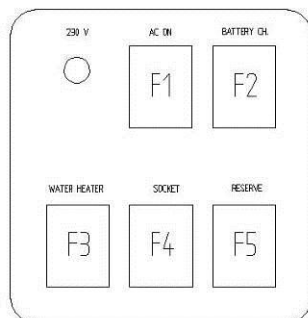
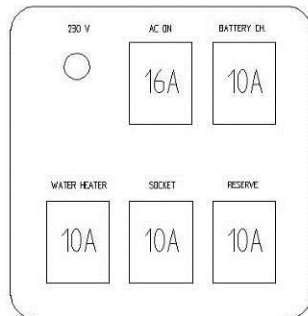

ELECTRICAL PANEL AC 230V FUSES

BOX UNDER COCKPIT RIGHT BACK SEAT

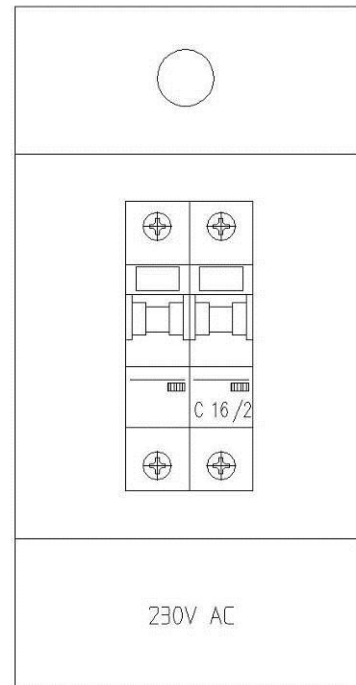

2F0-SHORE POWER FUSE

Figure 15

7.7. RUDDER AND STEERING SYSTEM

The boat is fitted with two connected rudders consisting of a long aluminium shafts passing through the deck and hull and a GRP rudder blade. The shaft goes almost to the end of the rudder blade. The rudders can be operated by either a tiller or a wheel (optional).

- WARNING:**
- In case of a defect of the steering mechanism, use the emergency tiller, available on the boat (in the cockpit locker) to get the boat to the nearest marina or service station.
 - Put the tiller on the shaft through the cover on the top bearing. The covers are located port and starboard in the cockpit floor.
 - In case of a defect of the mechanism, first remove the drag link (Fig.16)
 - Any contact of the rudder with the ground can cause the blade to break or split or the shaft to bend. It requires immediate checking and consultation with an expert.
 - Do not let go the steering tiller when you navigate backwards. Self-turning of the rudder can damage the steering mechanism.
 - Recommended speed should not exceed 2 knots.

- CAUTION:**
- It is recommended to disassemble the steering mechanism every two years to lubricate it and thoroughly check the rudder blade.
 - Clean the bearings and when reassembling, lubricate them with a lubricant resistant to sea water.

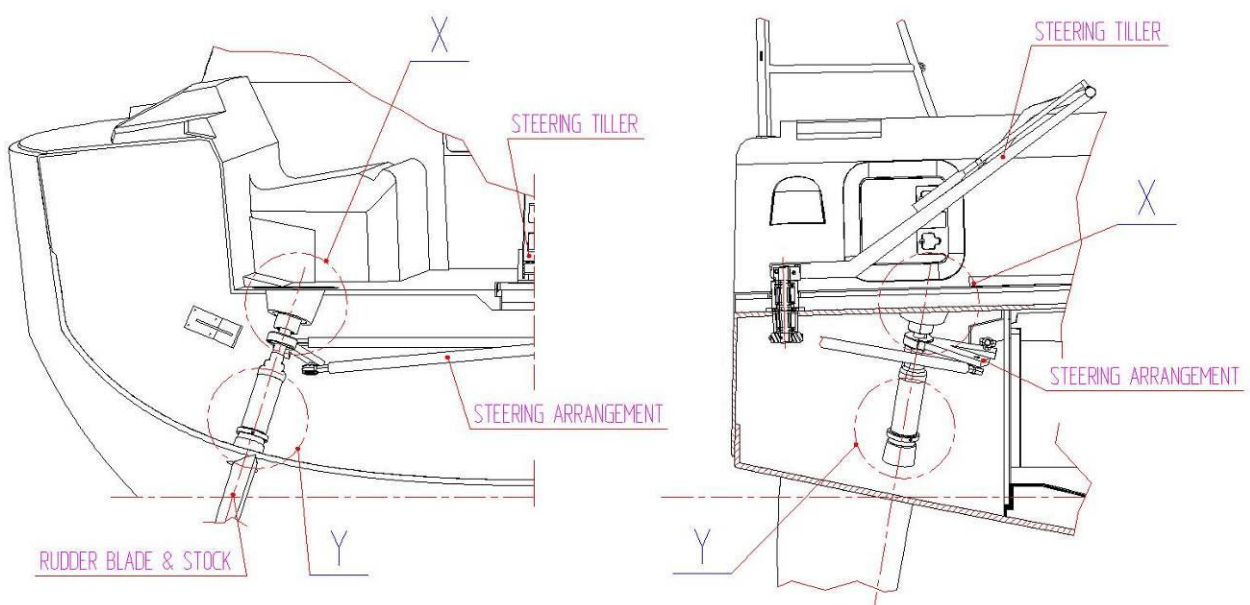

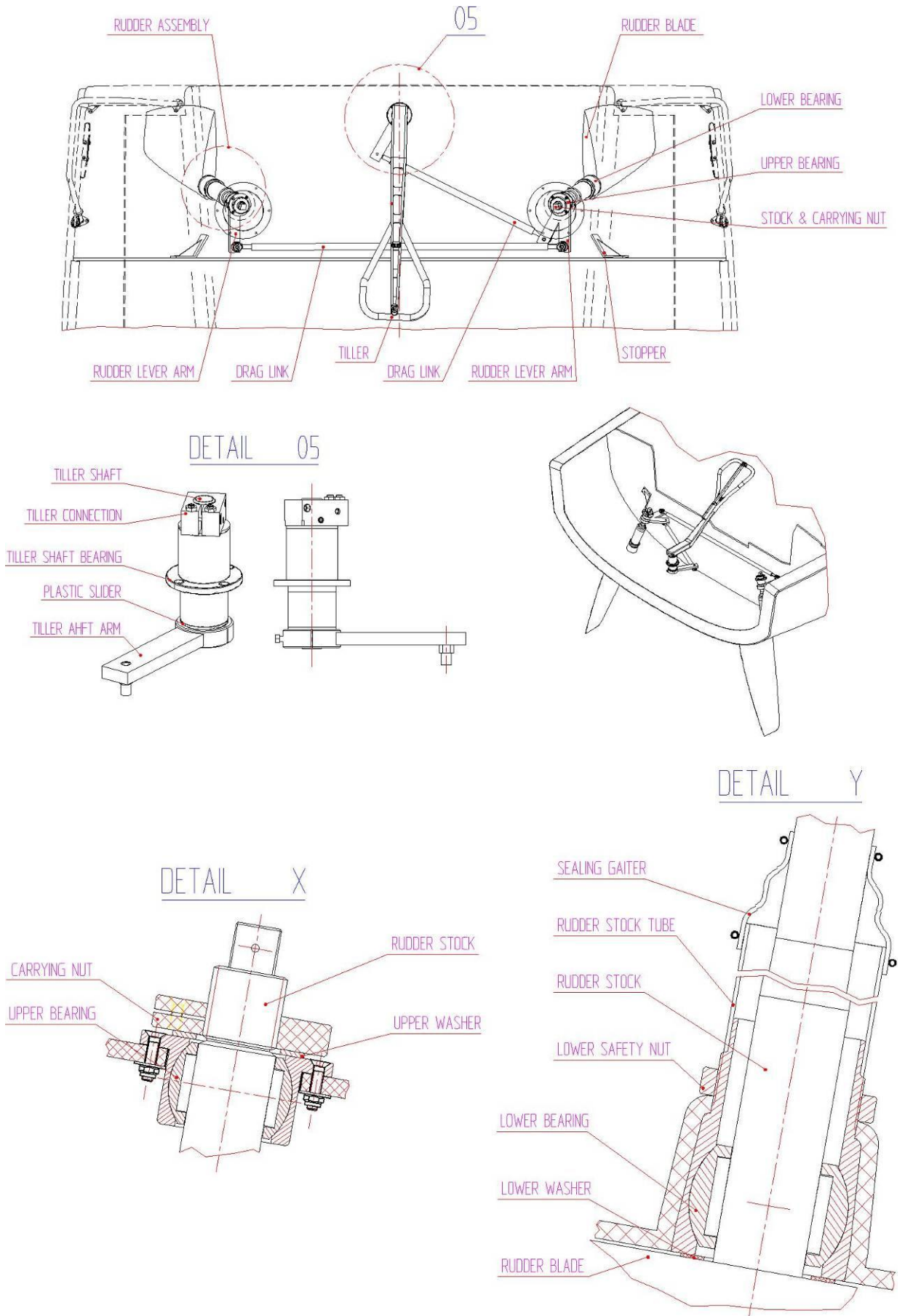

Figure 16

8. GARBAGE DISCHARGE

Annex V of the Marpol Treaty is an International Convention providing for a cleaner, safer marine environment.

IT IS THEREFORE ILLEGAL FOR ANY VESSEL TO DUMP PLASTIC GARBAGE INCLUDING SYNTHETIC ROPES, FISHING NETS AND PLASTIC GARBAGE BAGS ANYWHERE IN THE OCEANS OR NAVIGABLE WATERS.

Violations of these requirements may result in civil penalties being imposed upon offenders in the form of fines and/or legislation. Garbage must be disposed of as described in the ship's Garbage Management Plan and details of all garbage disposals must be kept in the garbage record book.

WARNING:

WITHIN 3 NAUTICAL MILES OF NEAREST LAND, ALL INLAND WATERS & FROM OR WITHIN 500M OF FIXED OR FLOATING PLATFORMS:

You can not throw anything overboard.

WITHIN 3-12 NAUTICAL MILES OFFSHORE:

You can not throw overboard paper, crockery, rags, metal, glass, food, plastic, dunnage and lining and packing materials that float.

You can throw overboard paper, crockery, rags, metal, glass and food, provided it is ground to less than 25 mm.

WITHIN 12-25 NAUTICAL MILES OFFSHORE:

You can not throw overboard plastic, dunnage, lining and packing materials that float.

You can throw overboard paper, crockery, rags, metal, glass and food etc.

OUTSIDE 25 NAUTICAL MILES OFFSHORE:

You can not throw overboard plastic.

NOTE:

In each case, plastic includes, but is not limited to synthetic rope, nites & plastic garbage bags.

All garbage discharges must be recorded in the garbage record book.

9. MAINTENANCE

9.1. HAULAGE

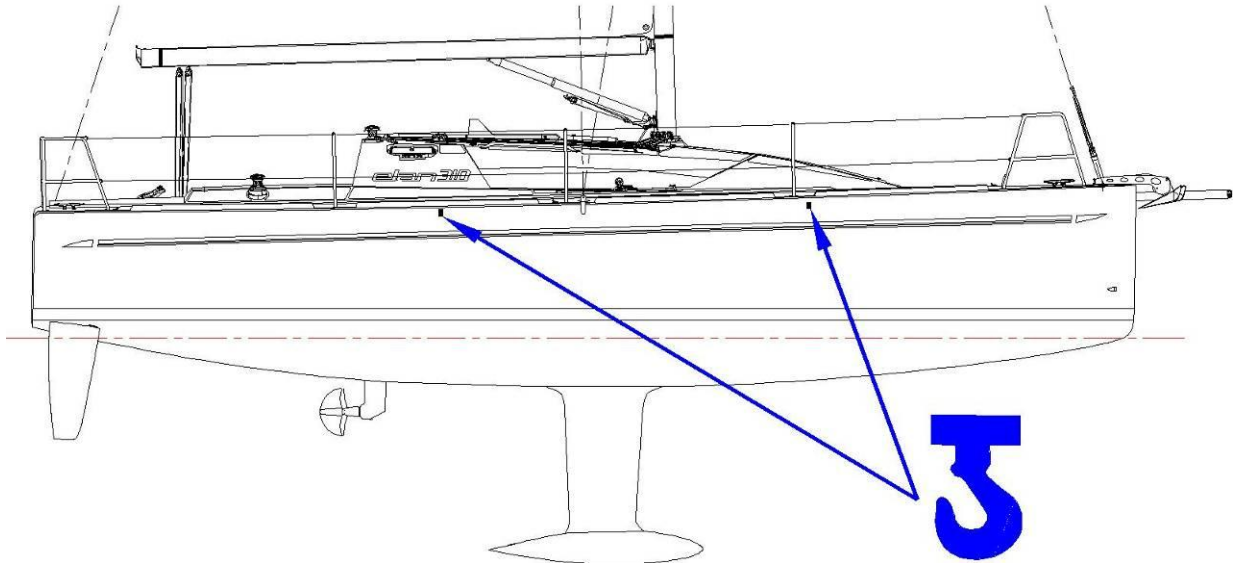

Figure 17

CAUTION: - Look for the labels on the boat to place the lifting straps (see Fig.17).
- Make sure the straps do not damage the sail drive or propeller.

DANGER: - It is not allowed to stay on board or stand under the boat when the boat is being hauled out.
- Make sure that the lifting straps meet all the safety requirements and that they are not damaged.

9.2. UNDERWATER STRUCTURE

9.2.1. HULL

An antifouling protects the underwater structure against fouling by marine growths that run down the performance and sailing ability of the boat. It is applied on the hull section that is immersed in water and up to about 100 to 150 mm above the waterline or up to the top stripe. It needs to be serviced at least once a year.

For a new boat it is very important to observe the following steps:

Use a 95% proof alcohol to remove all traces of the mould release agents and then wipe with absorbent paper or cloth.

To prepare the hull for the antifouling, gently sand it with sandpaper (400 grade).

Rinse thoroughly with cold fresh water without applying pressure or detergent and allow it to dry.

Apply the antifouling with a spray gun or a roller in accordance with the antifouling manufacturer's instructions.

For maintenance of the hull follow the next steps:

- Remove all algae and shells using a brush and fresh water.
- When cleaning with a high pressure hose and cold water, do not bring the hose any closer than 0,5 m.
- Allow the hull to dry.
- Apply the antifouling with a spray gun or roller in accordance with the antifouling manufacturer's instructions.

CAUTION: - When applying the antifouling, do not apply it on the instrument probes and terminals ends.
- Some antifouling paints are not compatible which is why particular care is required. When choosing another antifouling, consult a professional and keep records of the antifouling paints used.
- Follow the specifications and instructions laid down by the antifouling manufacturer.

WARNING: - When cleaning the underwater structure,
- **NEVER** use any solvent other than alcohol.
- **NEVER** use hot water under pressure.
- **NEVER** use cleaning agents under pressure.
- **NEVER** use a scraper.

9.2.2. PROTECTION OF TERMINALS

The zinc terminals of the underwater metal components (cast iron keel, sail drive and propeller) have to be replaced as soon as the terminals corrode up to half their length in order to ensure an adequate protection of the terminal ends.

WARNING: - Improper positioning or inadequate protection of terminal ends can cause irreparable damage to the metal parts.

9.3. HULL AND DECK

9.3.1. CLEANING

We recommend that you wash the exterior fibreglass surfaces of your boat several times each season using a mild detergent and large amounts of fresh water in order to remove the salt and dirt accumulated during use and as a result of air pollution.

After the boat has dried, use a good quality wax for protection against UV rays. We suggest that you should use a wax that does not contain silicone.

CAUTION: - **DO NOT** use aggressive (alkaline) cleaning agents for cleaning because they may cause changes in the gelcoat.

9.3.2. STAINS, SCRATCHES AND ABRASIONS

Use 95% proof alcohol to remove the stains that cannot be removed with a detergent and fresh water. Do not clean teak with alcohol. If the surfaces are not cleaned regularly, the top gelcoat layers can change color. Such stains can only be removed using a medium grade-rubbing compound. If this is ineffective, rub the area lightly with wet 800 to 1200-grade paper (used with water) until the mark disappears. A cleaning agent with fine abrasives can also be used to remove stains and minor scratches. After the stain has been removed, apply a wax polish.

WARNING: - Rubbing with abrasive compounds and materials removes the gelcoat. As this is only a thin layer, great care should be taken.
- **DO NOT** use organic solvents other than alcohol because they can cause result in permanent damage to the gelcoat and discoloration.

Gelcoat that is used as the exterior layer on your boat is very hard and resistant to shocks and scratching. However, it is practically impossible to avoid scratches when the boat is used. Minor scratches can be removed by sanding and polishing like stains. You will probably not be able to remove them completely but they will be less visible. Any scratches reaching to the fiberglass layer need to be repaired by applying gelcoat or another putty. If a scratch goes deep into the laminate or if it is a major scratch, we recommend you to have it repaired by a professional.

Any customer must be aware, if ordering a blue hull, that there may be white pixels visible in the blue hull. When sanding or polishing the hull the micro porosity of the laminate may be exposed. After final production, Elan yachts are sanded and polished, therefore extreme care must be exercised should further polishing be required.

DANGER: - In case of a crack or possible delamination, immediately consult an expert on laminates or contact the boat builder.

9.4. MAST, SAILS AND RIGGING

The standing rigging on your sailing yacht should be inspected regularly to ensure safe and trouble-free sailing. New rigging will often form a thin layer of rust, especially at the terminal ends. This is caused by impurities surfacing when the wire is cold-worked during manufacture. The oxidation should stop after a certain period of time, and when it does, remove the stain with an unchlorinated cleaner or a stainless steel polish. Rinse the turnbuckles and grease them lightly each season. Inspect the mast parts as well. Make sure that the Furlex system rotates easily. Wash away the salt, and then lubricate the bearings.

The sails need constant attention as the slightest wear in the stitching or at reinforced parts can quickly lead to their deterioration. Keep a small sail-maker's kit at hand. Bigger repairs should be made by a professional sail-maker. Sails dislike salt water and sunshine, so whenever you have the possibility, rinse the sails with plenty of fresh water and dry them completely before folding them.

To protect the sails from UV rays, always cover the mainsail folded on the boom with the mainsail cover. Remember to relieve outhaul tension before you start folding the mainsail. Genoa leech and foot already have sewn-on protective stripes that give a complete UV protection to a furled sail. When leaving the boat for a longer period or after the season, always remove, fold and store the sails in the sail sacks.

WARNING: - **DO NOT** ever let the sails flatter in the wind while drying as heavy damage to the stitching and sailcloth may result.

9.5. DECK EQUIPMENT

9.5.1. LIFELINES, PULPITS AND STANCHIONS

Lifelines and other rigging should be checked periodically. The terminal ends should be engaged properly in the barrels of the turnbuckles and the lock nuts tight. As the lines stretch, the slack should be taken up.

Stainless steel hardware can now and then show signs of rust that should be removed using an unchlorinated rust remover or a stainless steel polish. Rinse the equipment with fresh water and grease turnbuckles every year.

9.5.2. WINCHES AND BLOCKS

The winches should be cleaned and inspected before you go sailing. Check that the holding bolts are tight.

Blocks require little maintenance, except for periodic washing in fresh water and a light oiling with a silicone lubricant.

9.5.3. ANCHOR WINDLASS

Rinse the anchor locker and windlass with fresh water when you have the possibility. Clean and grease the rotating parts with the water resistant grease at least once a season. The internal parts of the windlass do not require maintenance for at least three seasons.

9.5.4. TEAK (optional)

A teak deck is exposed to sunlight and heat and salt water. If exposed to UV rays, it begins to put on a grey appearance and lose its original color. Scrub the teak deck, always across the grain of the wood with fresh water and a mild detergent several times a year and let it dry out. Then apply teak oil. Some teak treatments are not compatible with original Sika PU deck caulking. We recommend original Sika Marine Teak Deck Maintenance System according to their recommendations.

WARNING: - **DO NOT** clean teak deck with alcohol, acetone or gasoline or use teak maintenance systems based on the afore-mentioned substances.
- **DO NOT** use for teak strong or aggressive cleaners and brighteners.

9.5.5. PLEXIGLAS, PORTLIGHTS AND HATCHES

Wash your acrylic hatches and other acrylic components on your boat with a mild soap and plenty of warm water. Use a clean, soft cloth, applying only light pressure. Apply wax or non-acidic oil to such frames after cleaning.

WARNING: - To avoid cracking, never use any type of solvent when cleaning acrylic glass.
- **DO NOT** subject acrylic material to high temperature.
- **DO NOT** use cleaning agents like acetone, gasoline etc.

9.6. INTERIOR

9.6.1. INTERIOR WOOD SURFACES

Clean the varnished wood surfaces with fresh water and a clean cloth. Do not use organic solvents or expose surfaces to high temperatures to prevent permanent damage to the varnish.

Please keep in mind that wood is a natural product, therefore minor differences in colour can occur.

WARNING: - Worn wood parts can be painted with good quality polyurethane varnish. The varnish used must be compatible with the original one. Before applying the varnish, prepare the surface in accordance with the manufacturer's recommendations.

9.6.2. CUSHIONS AND CURTAINS

Use an upholstery shampoo of the foam type. When you leave the boat for a longer period of time, lift the cushions, allowing them to dry completely in order to prevent the growth of mildew underneath.

9.6.3. REFRIGERATOR

Clean your refrigerator before each sail and when leaving the boat for a longer period. Remove all the food and clean the fiberglass interior surfaces with a sponge and an appropriate cleaning agent. Leave the refrigerator cover open when you leave the boat to let the interior dry completely.

9.6.4. COOKER

Because only a clean cooker is safe, after any use clean the cooker thoroughly including the burners.

9.6.5. SINK

Stainless steel sinks may be cleaned with a non-abrasive cleaner and sponge.

9.6.6. BILGE STRAINERS AND PUMPS

After cleaning the boat's interior, proceed to inspect the bilge pump strainer and bilge, removing the dirt and drying it to prevent odour and mildew.

WARNING: - Dirt, hair, etc. should not be directly washed into the bilge during any cleaning process because they may plug the bilge pump and prevent it from regular functioning.

9.6.7. FUEL AND WATER TANKS

Inspect your tanks for any dirt regularly. Pay particular attention to any dirt accumulating at the bottom. The best way to clean the tanks is with a vacuum cleaner.

WARNING: - Inspect the fuel and water tanks only when you are sure that they are empty. Never unscrew the inspection hole when the tank is not empty.

10. WINTERISATION

It is recommended that all yachts should be lifted from water annually to allow the hull to dry out. The GRP that the hull is made of absorbs moisture when immersed in water, which can result in osmosis.

10.1. BLOCKING THE HULL

A sailing yacht is properly supported when the weight of the hull is resting on the keel. The purpose of cradle bulkhead is just to keep the boat balanced in an upright position. Before hauling the boat out, check that the crane straps are positioned on the signed marks on the hull (see Fig.18)

10.2. COOKER

Clean the cooker thoroughly, including the burners. Burn off excess gas in the feed line by closing the valve on the gas bottle with the gas burner lit. When the flame is extinguished, the gas in the feed line is burned. Be sure to turn all the valves on the appliance to the OFF position. Make sure that the gas locker is clear.

10.3. ELECTRICAL SYSTEM

Remove all the batteries from the boat and clean the poles. Store the batteries in a warm and dry location. The batteries should be completely charged before storing. The rest of the electrical system requires little maintenance. Extremely adverse weather conditions may cause corrosion. In that case we recommend you to clean off any corrosion and apply an anti-corrosive agent.

10.4. WATER SYSTEMS

Pump tanks as dry as possible, than add a non-toxic water system winterised. Pump this solution through the entire fresh-and waste-water systems.

WARNING: - Leave all the seacocks open.
- **DO NOT** use antifreeze or other poisonous substances.

10.5. SEACOCKS

Clean them carefully from inside and outside of the boat and put some water resistant grease on all the moving parts.

10.6. FUEL TANK

Fill the fuel tank completely to prevent water condensation and corrosion.

10.7. ENGINE

Thoroughly clean oil and fuel from the engine compartment. Winterisation should be done in accordance with the engine manufacturer's recommendations. Remember to disconnect the cooling water intake to make sure no water remains in the system. Inspect all the electrical connections and spray them with an anti-corrosion spray.

10.8. SAILS

Thoroughly wash all the sails, inspecting them at the same time. Fold the completely dried sails and store them in a dry and dark place. If necessary, use a mild soap to remove the stains. If you find any damage, bring the sail to a sail-maker for a detailed inspection and repair.

10.9. COVERING

It is much better to store a sailing yacht under cover than to leave it exposed to the weather conditions. The teak and gelcoat will fare far better during the winter and the boat will not be exposed to the pressure of the freezing water, a common cause of gelcoat stress cracks.

10.10.CUSHIONS

Remove the cushions from the boat for winterisation, let them dry out and store them in a dry place.

10.11.INTERIOR

Make sure that the interior is well ventilated. Open all the lockers, covers and doors to allow for adequate air circulation.

11. PRODUCT END OF LIFE DISPOSAL

Prior the boat disposal (after end-of-life cycle) the owner needs to identify all legal requirements that are applicable to this environment aspect. Since our boats are generally sold worldwide, this may include:

- National and international legal requirements;
- State / provincial / department legal requirements;
- Local government legal requirements.

Your sailing boat is a highly complex product, with many different sub-systems and installed sub-products, therefore we suggest contacting applicable authorities for further information.

Additional special care needs to be taken for more aggressive items, such as batteries, fuels and cooling agents, engine fluids etc., which should be disposed according to the suppliers instructions.

In some areas boat disposal companies are also available, which will help you to dispose a product in a right and environment friendly way.

INSTRUCTIONS FOR USE OF INSTALLED EQUIPMENT

- 1. Refrigerator.....
- 2. Water heater.....
- 3. Instruments.....
- 4. Engine.....
- 5. Etc.

	ELEMENT	MANUFACTURER	TYPE
1			
2			
3			
4			
5			
6			
7			
8			
9			
10			
11			
12			

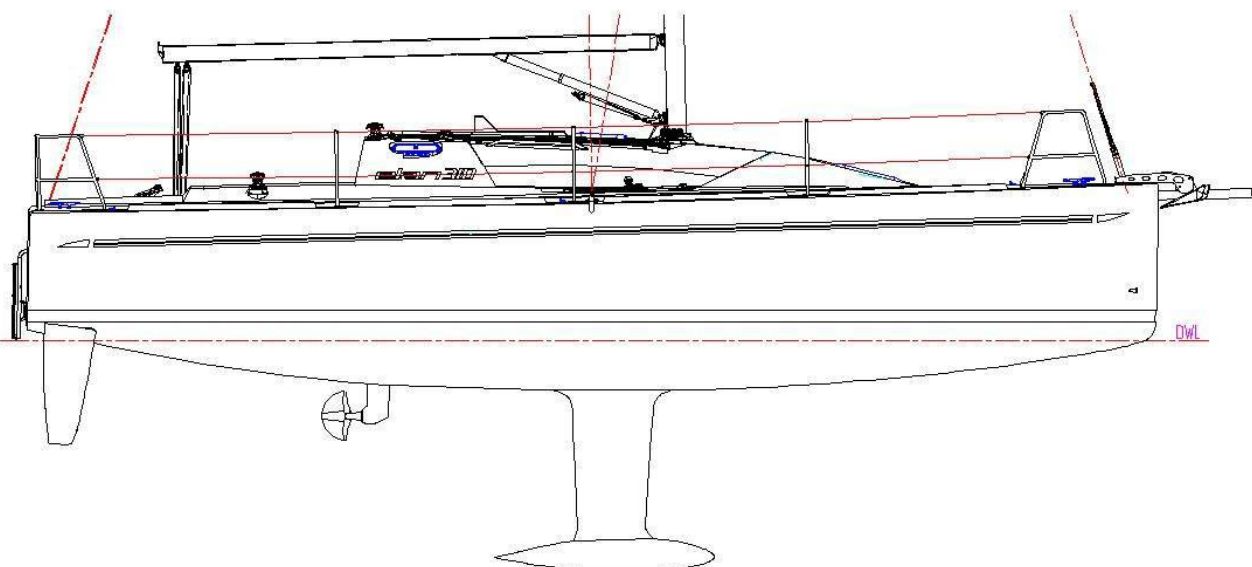
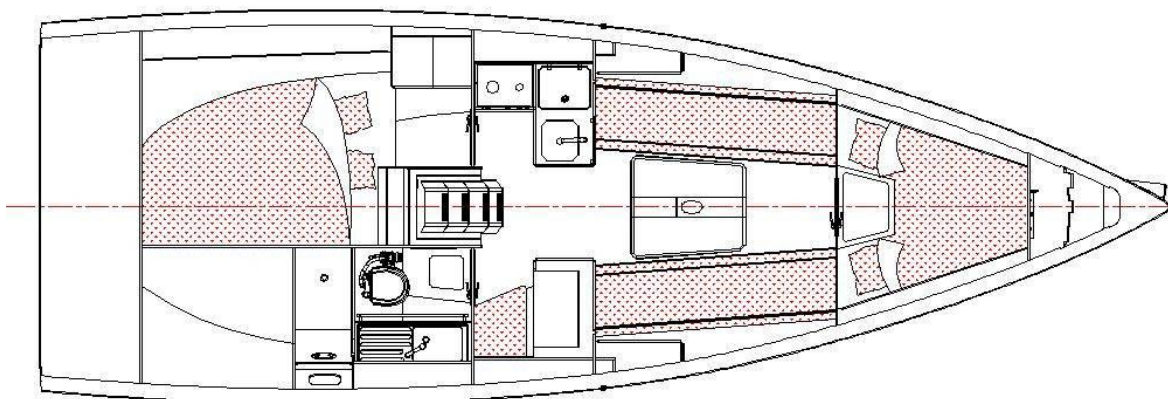
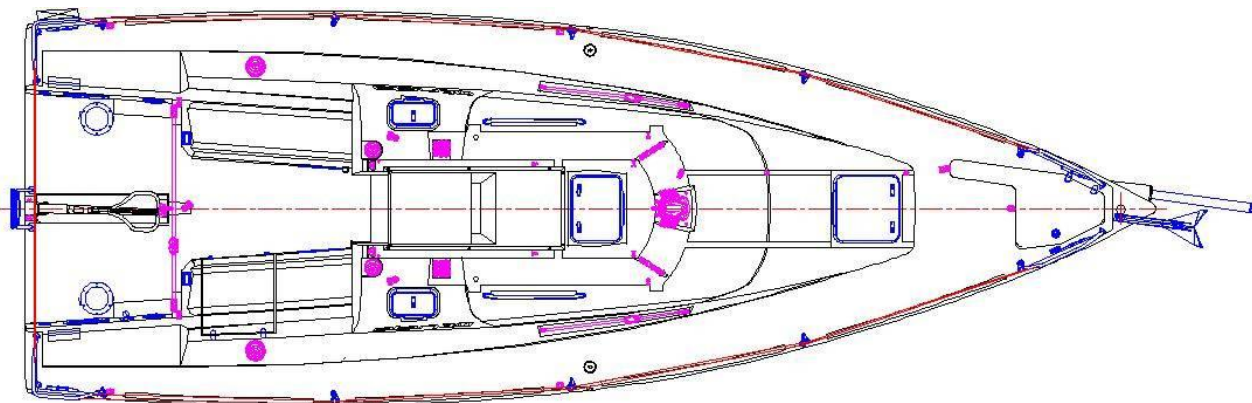

ELAN MARINE d.o.o.
Begunje 1
4275 Begunje na Gorenjskem
Slovenia
Tel: +386 45 351 370
Fax: +386 45 351 360
e-mail: elan.marine@elan.si
http: www.elan-yacht.com

Webasto heating assembly:

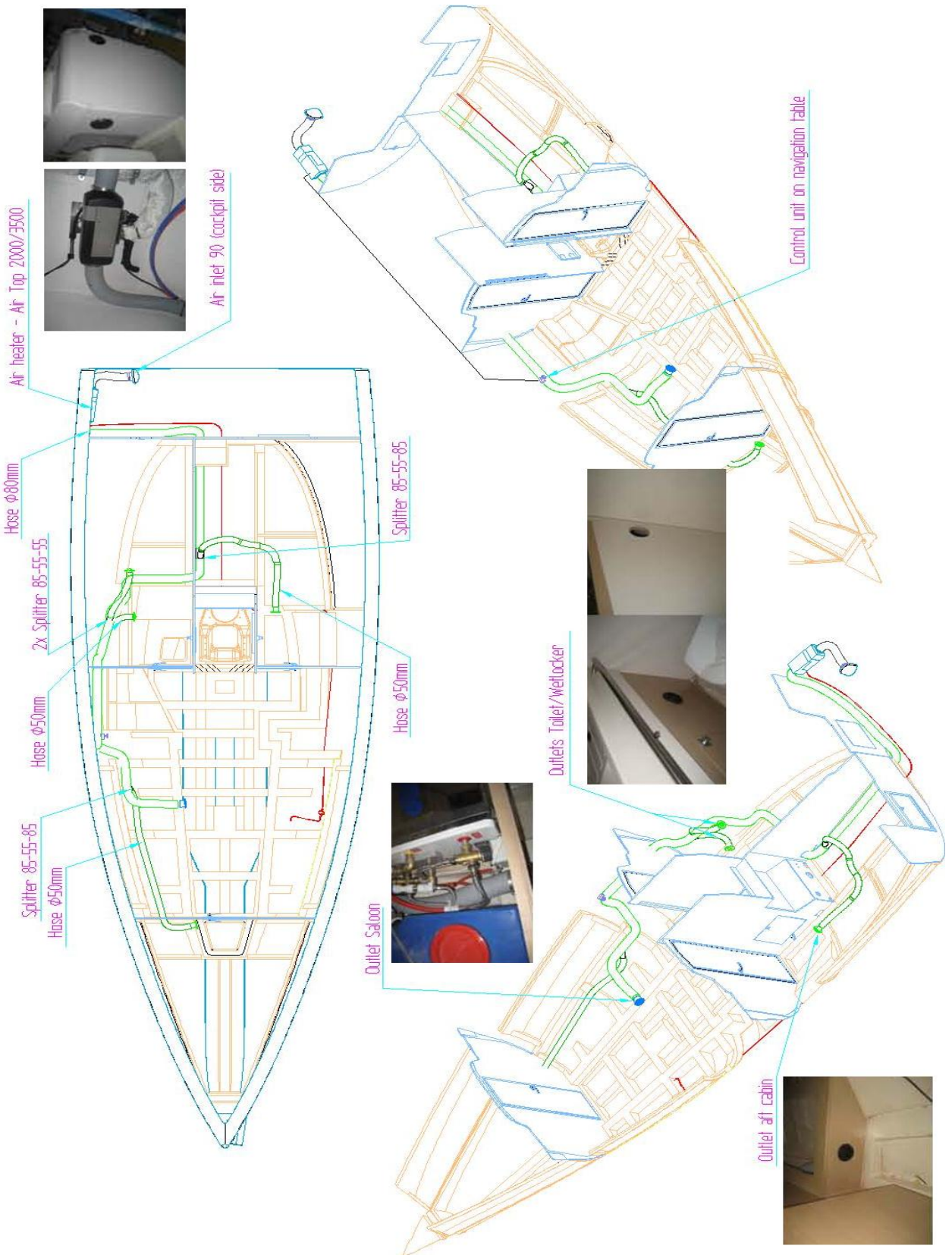
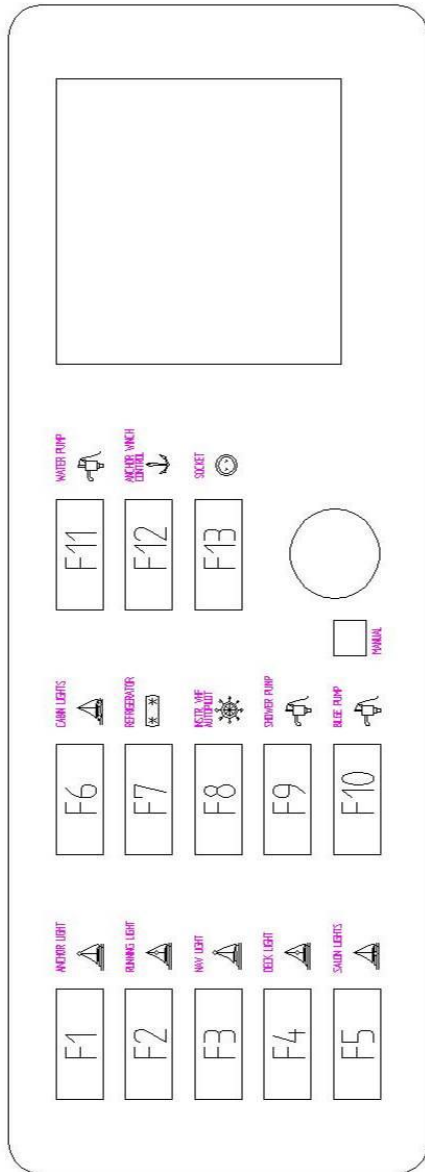
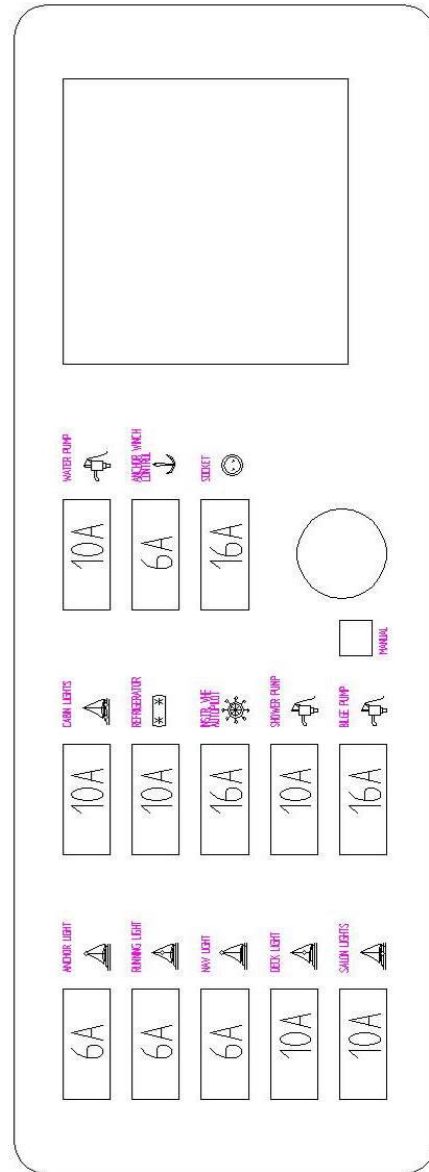

Figure 18



ELECTRICAL PANEL DC 12V (FUSES)



ELECTRICAL PANEL DC 12V (FUSES CAPACITY)

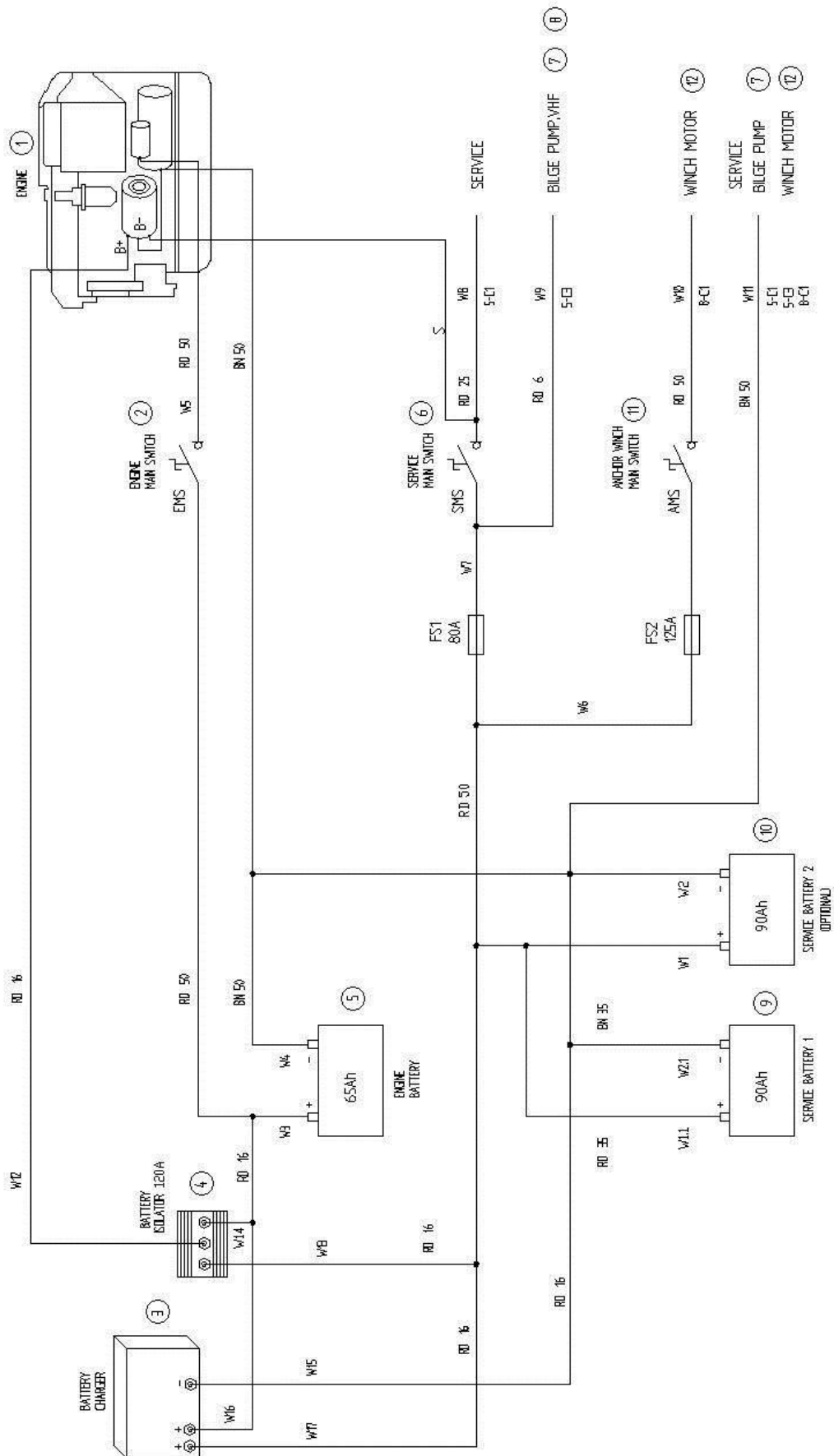

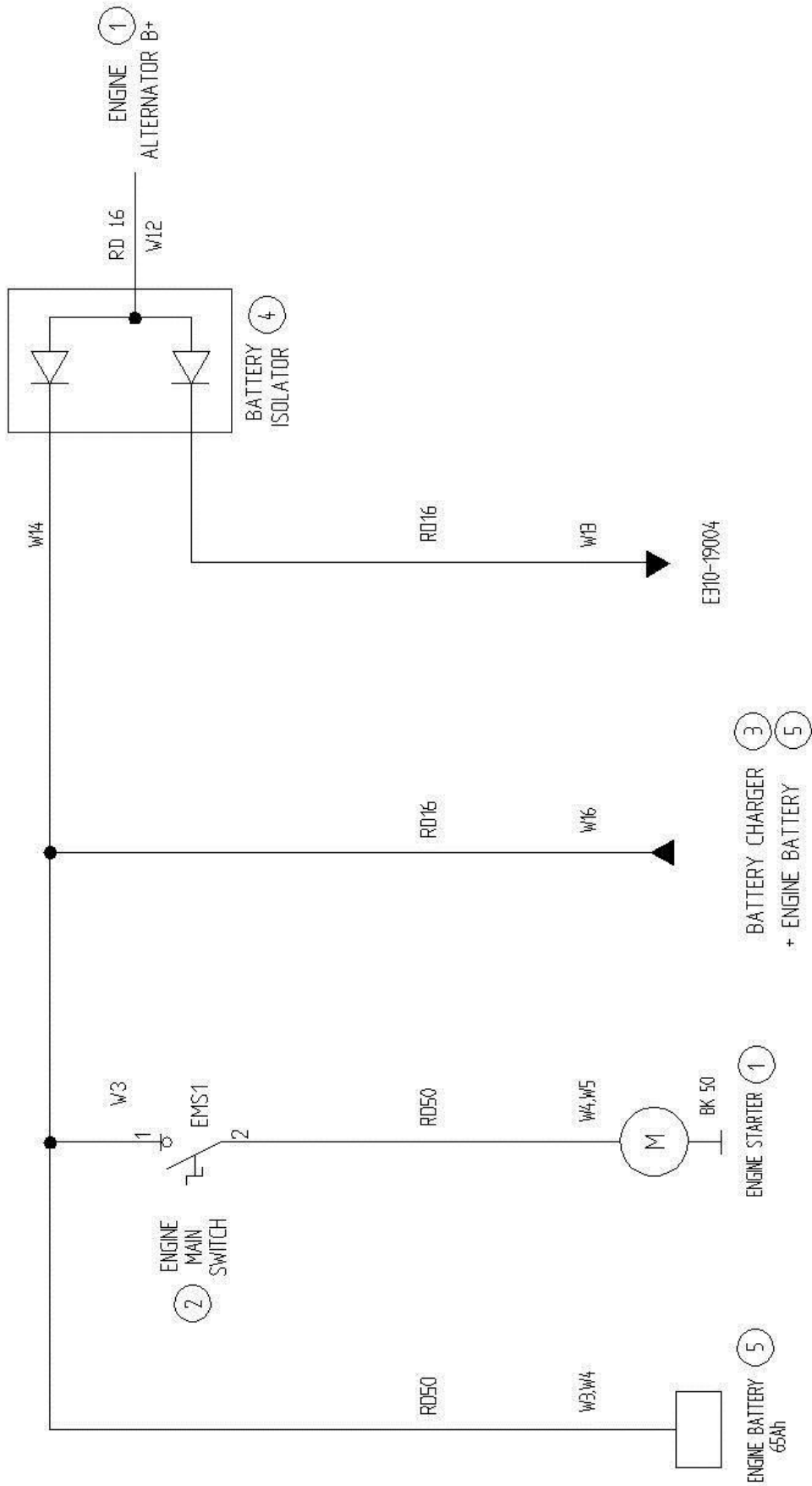

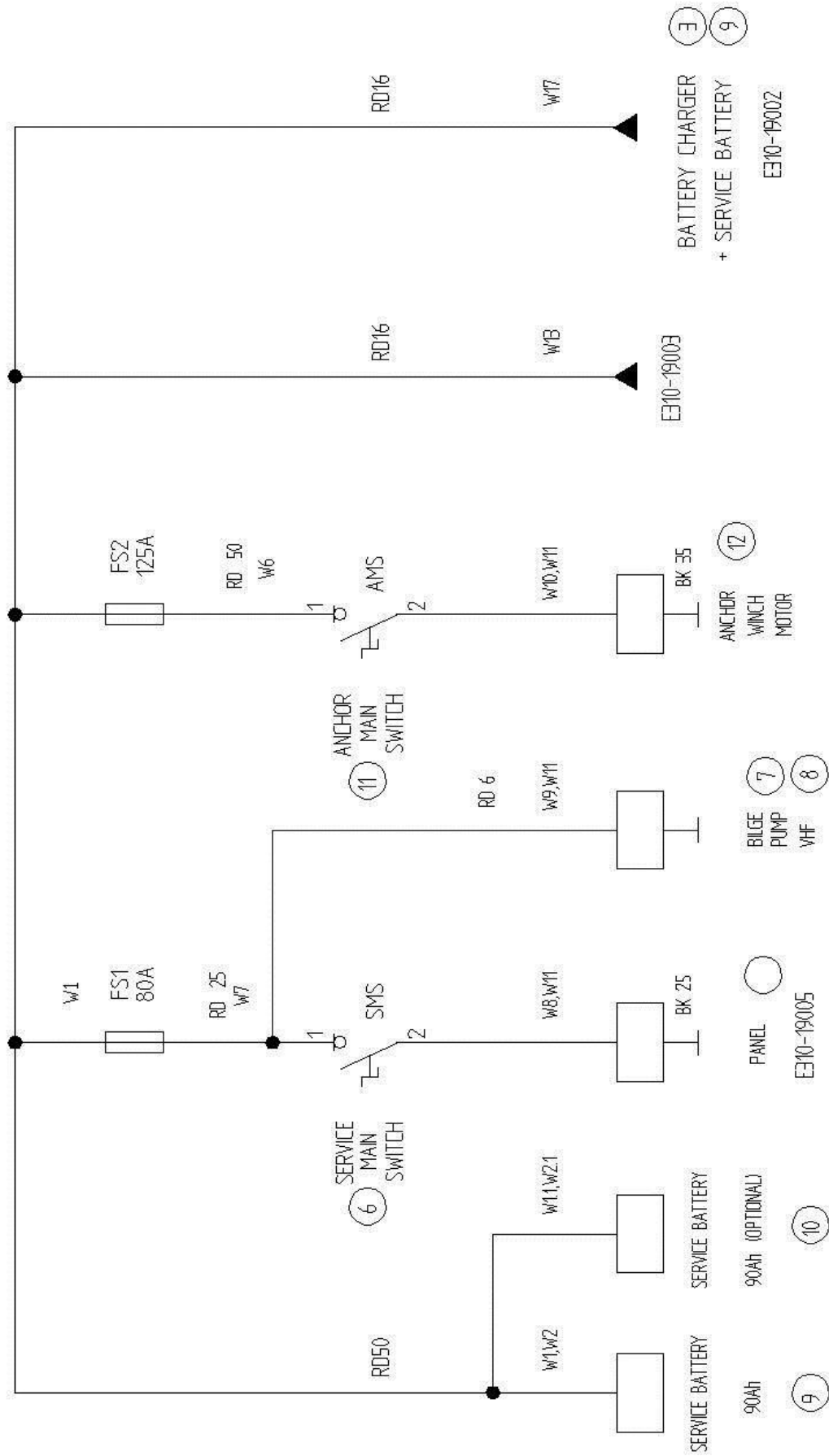

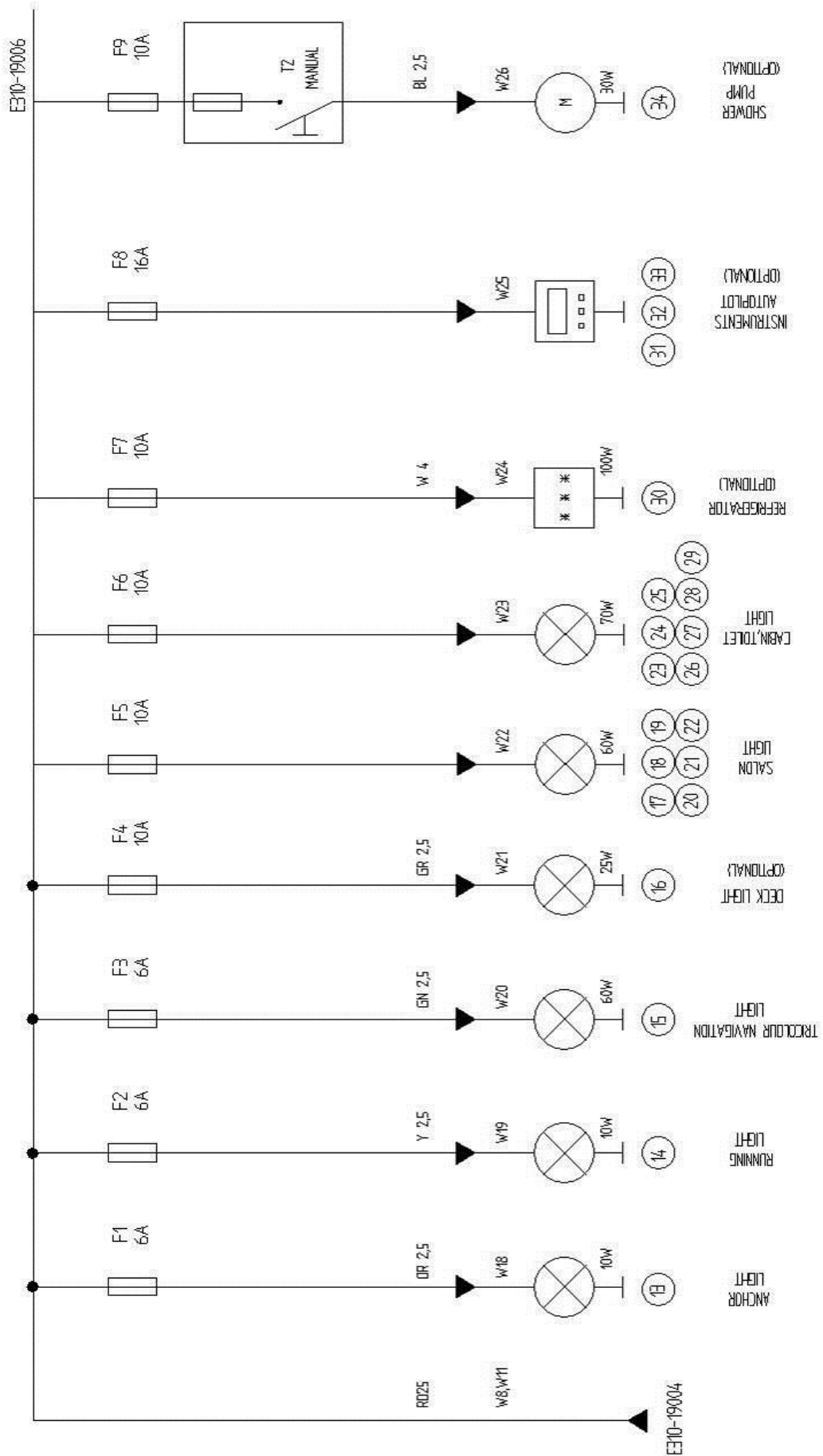

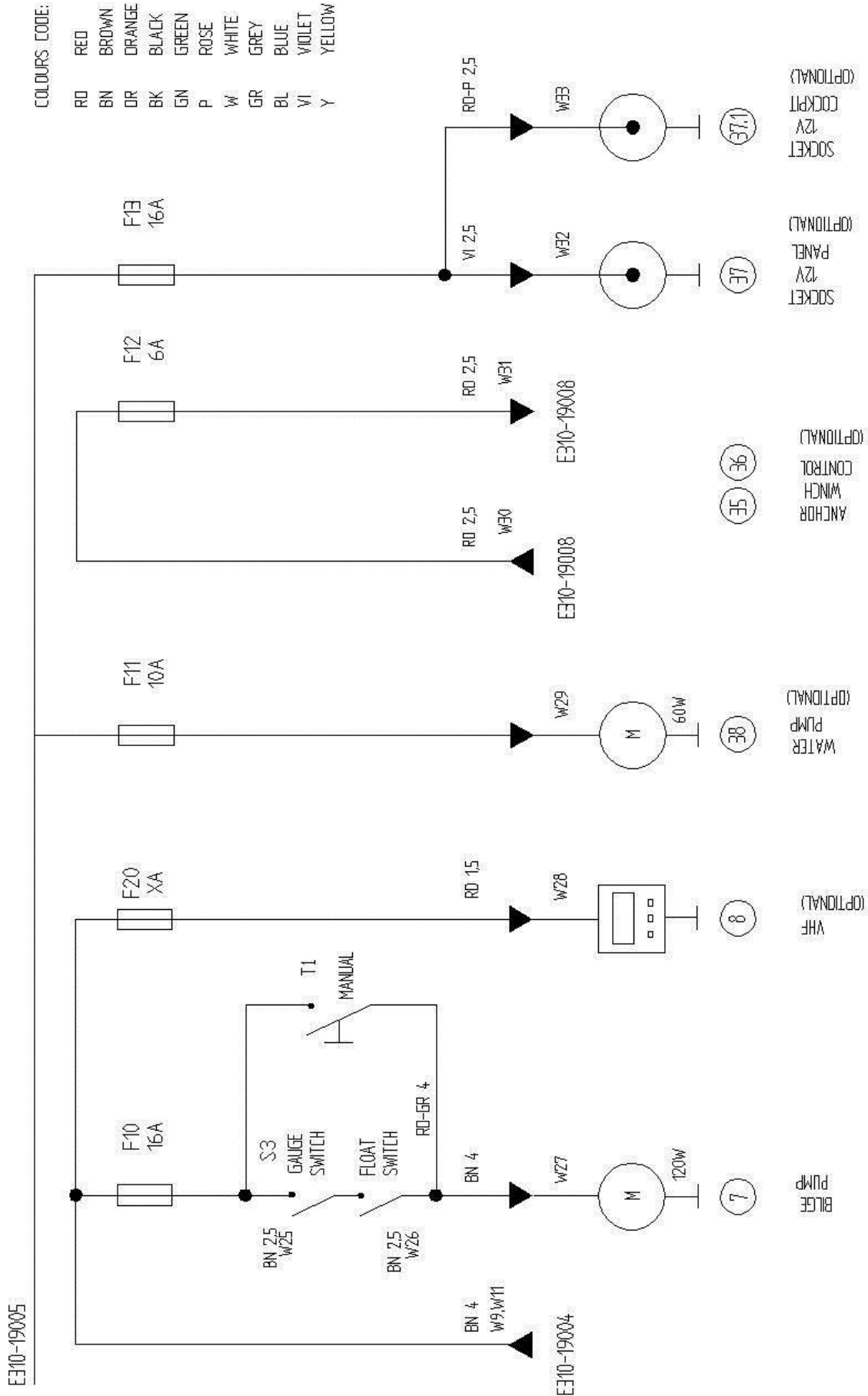

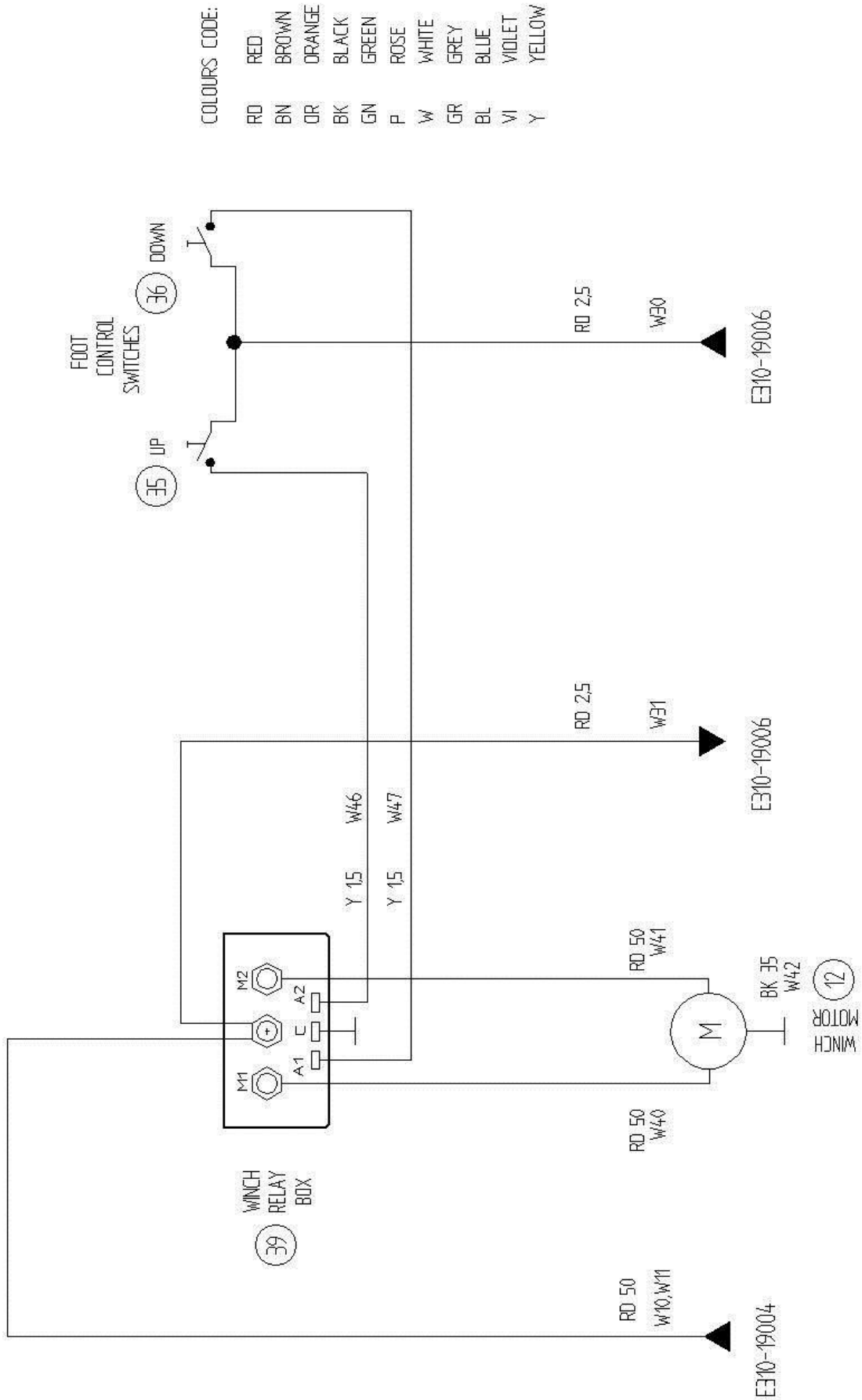

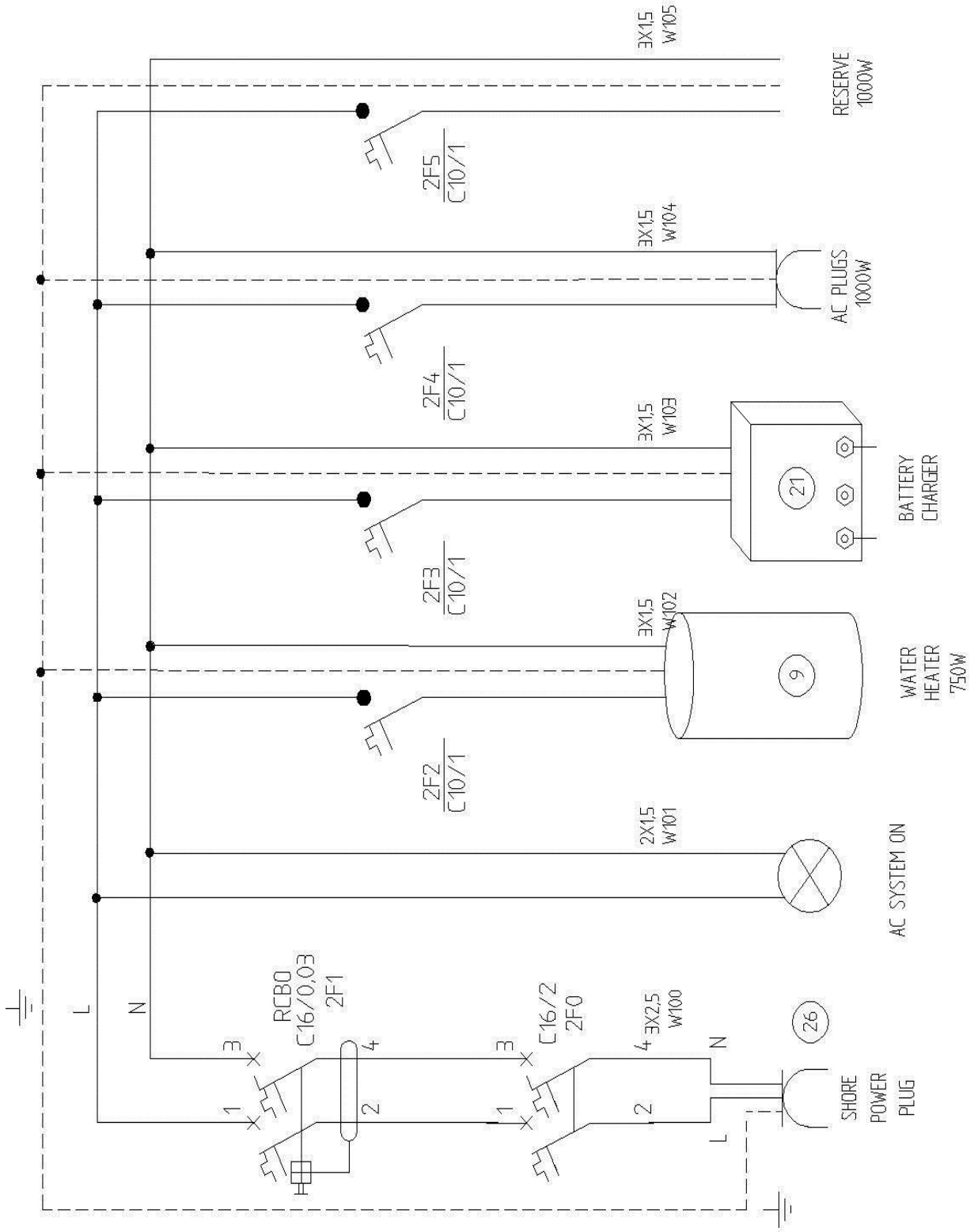

BOX UNDER COCKPIT RIGHT BACK SEAT

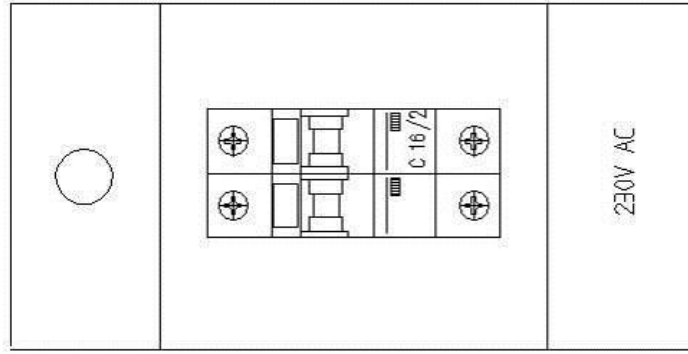

230V AC
2FO-SHORE POWER FUSE

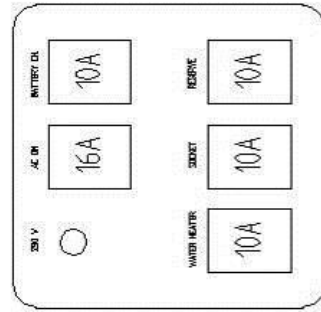

ELECTRICAL PANEL AC 230V FUSES CAPACITY

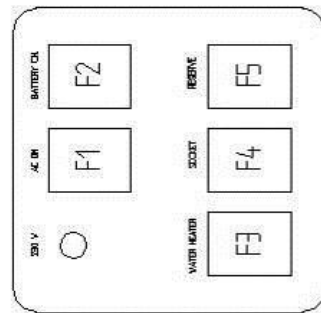

ELECTRICAL PANEL AC 230V FUSES

DISTRIBUTION STRIP 2

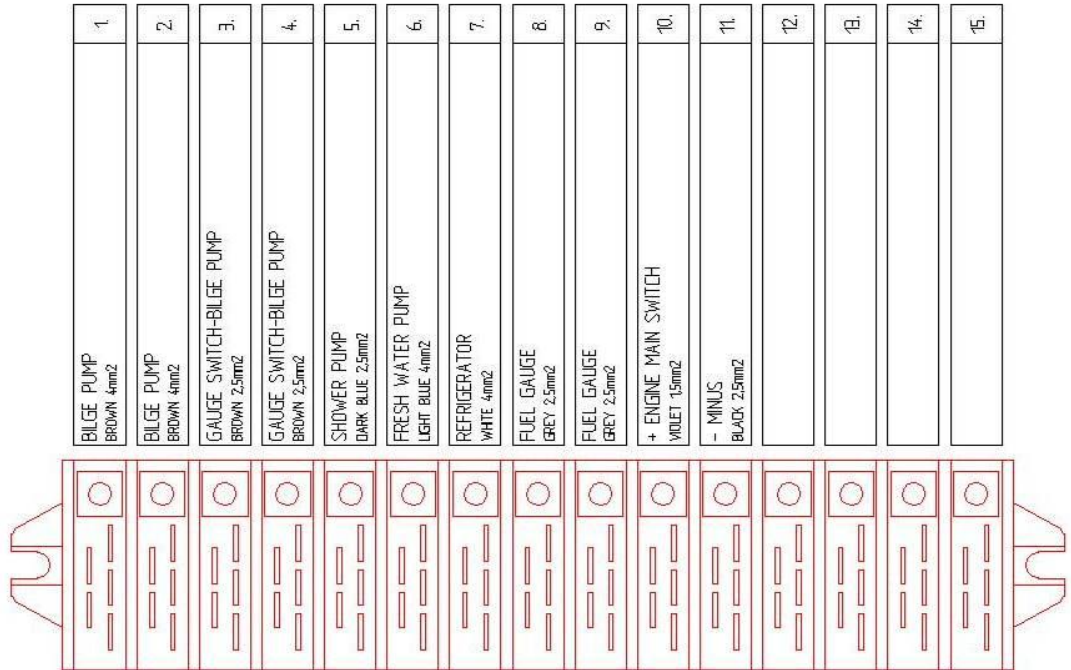

DISTRIBUTION STRIP 1

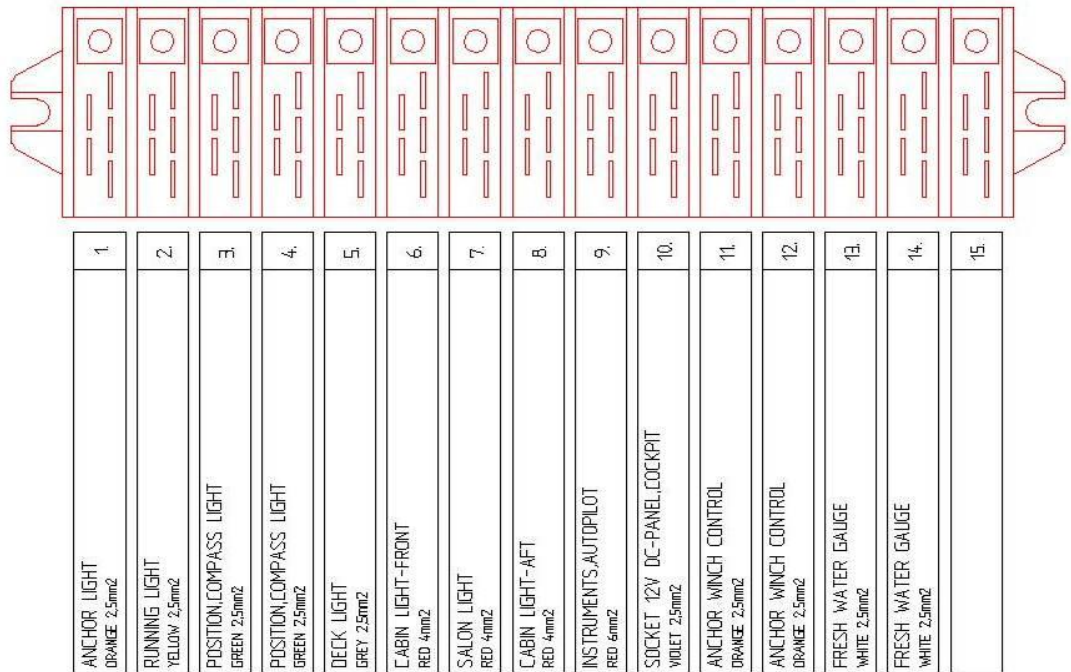

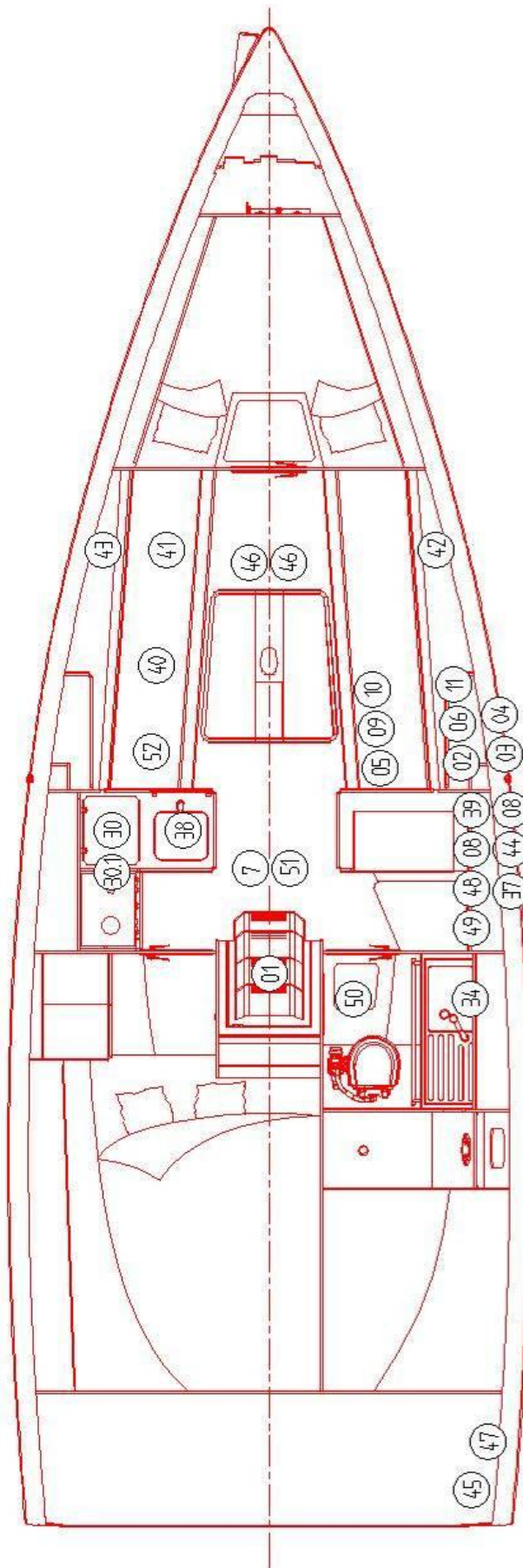

- 01-DIESEL ENGINE
- 02-MAIN SWITCH-ENGINE
- 03-BATTERY CHARGER
- 04-BATTERY ISOLATOR 2X120A
- 05-ENGINE BATTERY 65Ah
- 06-MAIN SWITCH-SERVICE
- 07-BILGE PUMP
- 08-VHF-(OPTIONAL)
- 09-SERVICE BATTERY 90Ah
- 10-EXTRA BATTERY 90Ah-(OPTIONAL)
- 11-MAIN SWITCH-ANCHOR WINCH
- 30-REFRIGERATOR
- 34-SHOWER PUMP-(OPTIONAL)
- 37-SOCKET DC 12V(OPTIONAL)
- 38-WATER PUMP
- 39-ANCHOR WINCH RELAY
- 40-FUEL GAUGE-LEVEL SENSOR
- 41-FRESH WATER GAUGE-LEVEL SENSOR
- 42-RIGHT SPEAKER-SALON (OPTIONAL)
- 43-LEFT SPEAKER-SALON (OPTIONAL)
- 44-RADIO-(OPTIONAL)
- 45-SHORE POWER FUSE (COMBINED RCD/MCB DEVICE 230V)
- 46-DEPTH,SPEED TRANSDUCERS-(OPTIONAL)
- 47-WEBASTO
- 48-ELECTRICAL PANEL AC 230V
- 49-ELECTRICAL PANEL DC 12V
- 50-SHOWER PUMP- FLOAT SWITCH
- 51-BILGE PUMP FLOAT SWITCH
- 52-ELECTRIC WATER HEATER

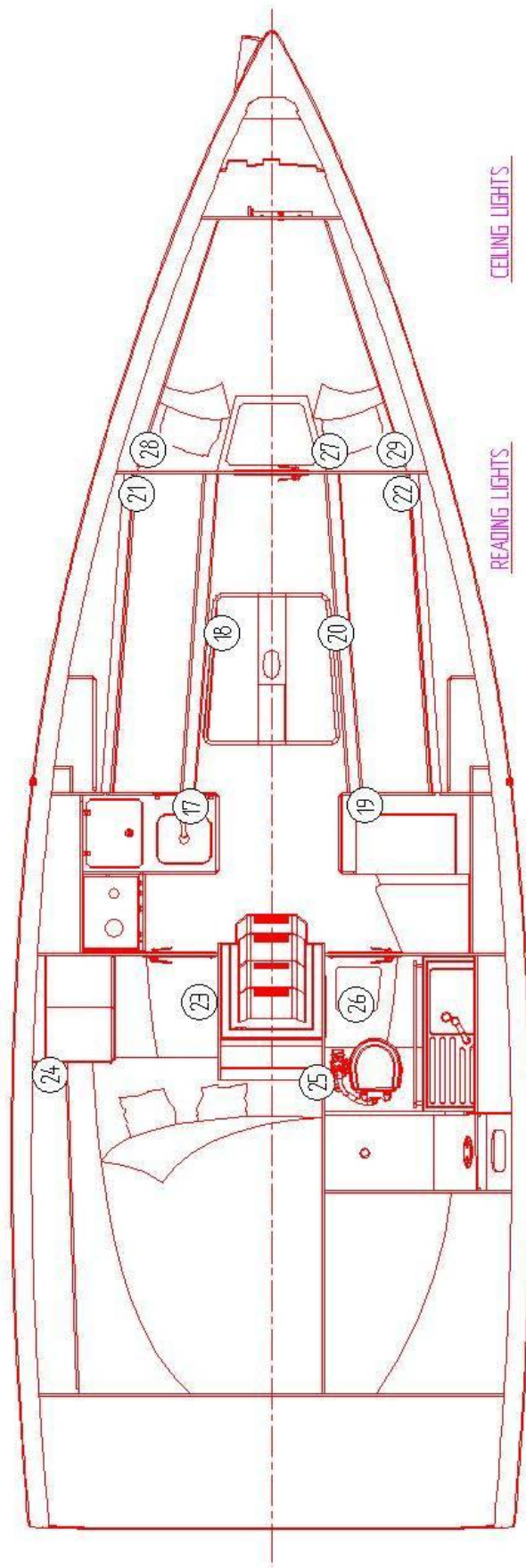

CEILING LIGHTS

- 17 GALLEY
- 18 SALOON
- 19 NAVIGATION
- 20 SALOON
- 23 AFT CABIN
- 26 TOILET
- 27 FORWARD CABIN

READING LIGHTS

- 21 SALOON
- 22 SALOON
- 24 AFT CABIN
- 25 AFT CABIN
- 28 FORWARD CABIN
- 29 FORWARD CABIN

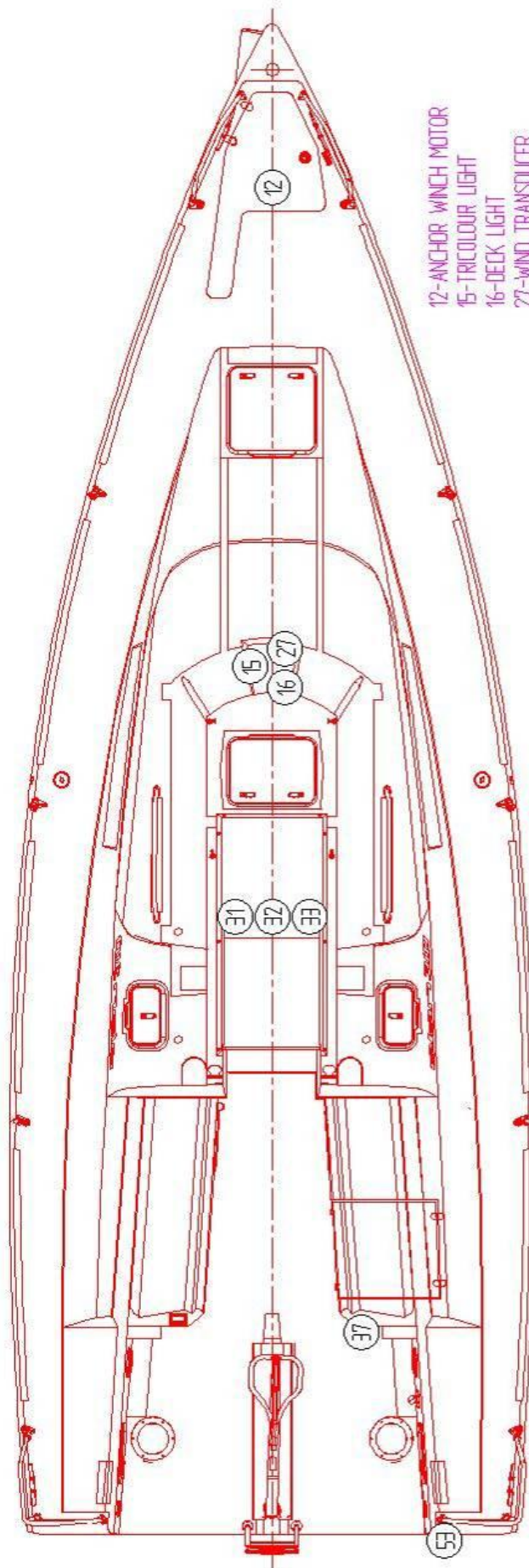

- 12-ANCHOR WINCH MOTOR
- 15-TRICOLOUR LIGHT
- 16-DECK LIGHT
- 17-WIND TRANSDUCER
- 27-INSTRUMENT
- 31-INSTRUMENT
- 32-INSTRUMENT
- 33-INSTRUMENT
- 37-SOCKET DC 12V (OPTIONAL)
- 53-SHORE POWER